



COMPUERTA, GLOBO Y RETENCIÓN

Catálogo de Producto



SOLUTIONS
for the process industry

>> connect with www.saldi.es | www.klinger-international.com





COMPUERTA, GLOBO Y RETENCIÓN

Catálogo de Productos



CONTENIDO

VÁLVULAS FUNDIDAS	06
» VÁLVULAS ANSI	08
» Válvulas de Compuerta	10
» Válvulas de Globo	38
» Válvulas de Retención	72
» Válvulas Forjadas Pressure Seal	96
» Válvulas de Fuelle	106
» Ejecuciones especiales	135
» Válvulas para Alquilación	167
» VÁLVULAS DIN	209
» Válvulas para Uso Naval	219
» Ejecuciones especiales	225
VÁLVULAS FORJADAS	262
» Válvulas de Compuerta	268
» Válvulas de Globo	292
» Válvulas de Retención	314
» Válvulas Forjadas Pressure Seal	331
» Válvulas Pressure Seal DIN	353
» Válvulas Through Conduit	357
» Válvulas para Servicio Urea	363
VÁLVULAS DE RETENCIÓN DISCO	371
» Válvulas de Retención Disco CRANE®	372
VÁLVULAS DE RETENCIÓN NOZZLE	381
» Válvulas de Retención Nozzle CRANE®	382
VÁLVULAS DE BRONCE Y LATÓN	387
» Válvulas de Bronce y Latón CONTI	388
APÉNDICES	415
» Juntas recomendadas, Tablas e Información Técnica	416

VÁLVULAS FUNDIDAS



CAST STEEL VALVES

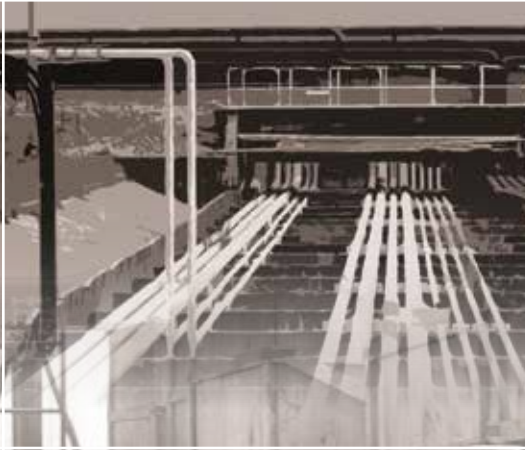
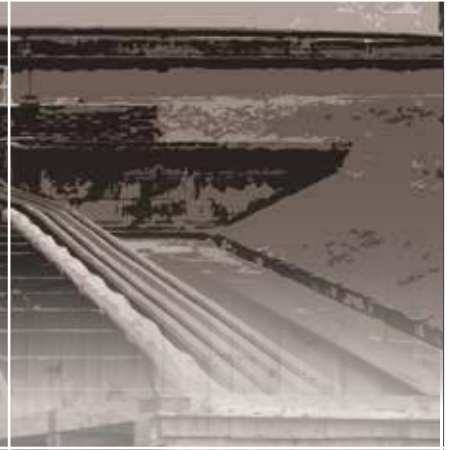



American National Standards Institute

Class 1500

Class 900

Class 150

CLASS 300

Class 600

Class 2500

VÁLVULAS ANSI



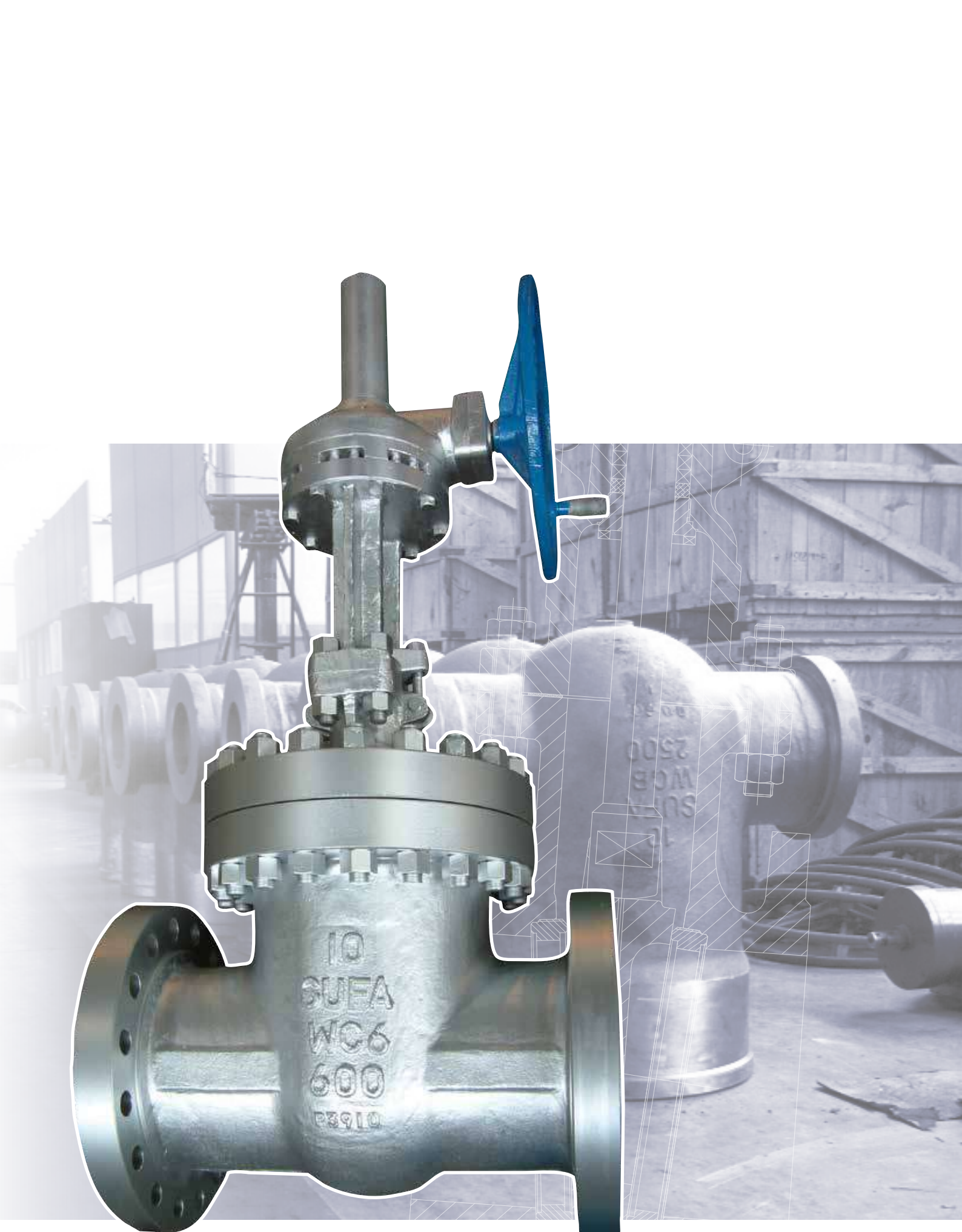

VÁLVULAS DE COMPUERTA - LISTA DE MATERIALES DE CONSTRUCCIÓN ESTÁNDAR

PIEZA	ACERO CARBONO		ACERO ALEADO				ACERO INOXIDABLE			
Cuerpo	A216 WCB	A352 LCB	A217 WC1	A217 WC6	A217 WC9	A217 C5	A351 CF8	A351 CF8M	A351 CF3	A351 CF3M
Tapa	A216 WCB	A352 LCB	A217 WC1	A217 WC6	A217 WC9	A217 C5	A351 CF8	A351 CF8M	A351 CF3	A351 CF3M
Tornillos cuerpo-tapa	A193 B7	A320 L7	A193 B7	A193 B16	A193 B16	A193 B16	A193 B8	A193 B8	A193 B8	A193 B8
Tuercas cuerpo-tapa	A194 2H	A194 Gr. 4	A194 2H	A194 Gr. 4	A194 Gr. 4	A194 Gr. 4	A194 Gr. 8	A194 Gr. 8	A194 Gr. 8	A194 Gr. 8
Linterna ¹	410	410	410	410	410	410	304	316	304L	316L
Pasadores	Acero	Acero	Acero	Acero	Acero	Acero	Acero inox	Acero inox	Acero inox	Acero inox
Prensaestopas	A182 F6	A182 F6	A182 F6	A182 F6	A182 F6	A182 F6	304	316	304L	316L
Brida prensa	A105	A350 LF2	A105	A105	A105	A105	304	316	304L	316L
Tornillo prensa	A193 B7	A320 L7	A193 B7	A193 B7	A193 B7	A193 B7	A193 B8	A193 B8	A193 B8	A193 B8
Tuercas	A194 2H	A194 Gr. 4	A194 2H	A194 2H	A194 2H	A194 2H	A194 Gr. 8	A194 Gr. 8	A194 Gr. 8	A194 Gr. 8
Junta cuerpo-tapa	Plana en Grafito, Espirometálica en Acero inoxidable/Grafito o PTFE reforzado ²									
Empaquetadura	Anillo de Grafito trenzado o preformado, o PTFE									
Tuerca husillo	A439 D2 o A276 410									
Tuerca fijación	Acero									
Volante	Hierro Fundido									
Tuerca volante	Acero									
Engrasador	Acero									
Placa identificación	Acero inoxidable o Aluminio									

Otros materiales (Alloy 20, AISI 321, AISI 347, Monel, Hastelloy, etc.) bajo demanda

¹Las válvulas de COMPUERTA 150LBS no llevan linterna

²Junta de Grafito sólo para válvulas de COMPUERTA 150LBS

MATERIALES DEL TRIM SEGÚN API 600¹

CÓDIGO ASIENTO	SUPERFICIE ASIENTO DEL CUERPO	SUPERFICIE ASIENTO DE LA CUÑA	HUSILLO	CIERRE TRASERO
X	F6	F6	F6	F6
U	Stellite	Stellite	F6	F6
XU	Stellite	F6	F6	F6
P	F304	F304	F304	F304
R	F316	F316	F316	F316
M	Monel	Monel	Monel	Monel
N	Alloy 20	Alloy 20	Alloy 20	Alloy 20
H	Hastelloy B	Hastelloy B	Hastelloy B	Hastelloy B
B	Bronce	Bronce	Bronce	Bronce
T	Inserto de PTFE reforzado	CF8	Acero inox.	Acero inox.

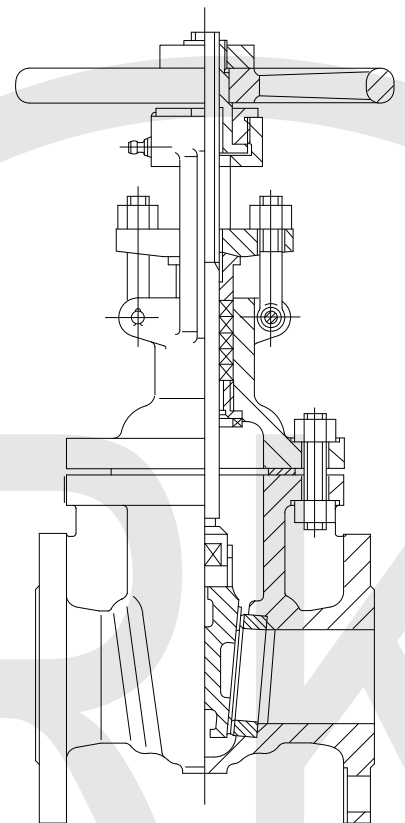

¹ Encontrará más información sobre materiales del trim al final de este catálogo

VÁLVULAS FUNDIDAS ANSI

COMPUERTA 150LBS 2" - 8" BRIDAS

COMPUERTA Fig. GA01011XU		Clase: 150LBS
VÁLVULA COMPUERTA ACERO CARBONO 150LBS BRIDAS		
Especificaciones		
Material	Acero carbono ASTM A216 WCB ¹	
Diseño	API 600	
Conexiones	Bridas según ASME B16.5 RF	
Longitud	ASME B16.10	
Inspección y Pruebas	API 598	
NACE MR 01-75	Bajo demanda	
Aplicaciones	Refinerías, Petroquímica, Química, Metalurgia, Papel, Farmacéuticas...	
¹ Ver lista de materiales estándar		

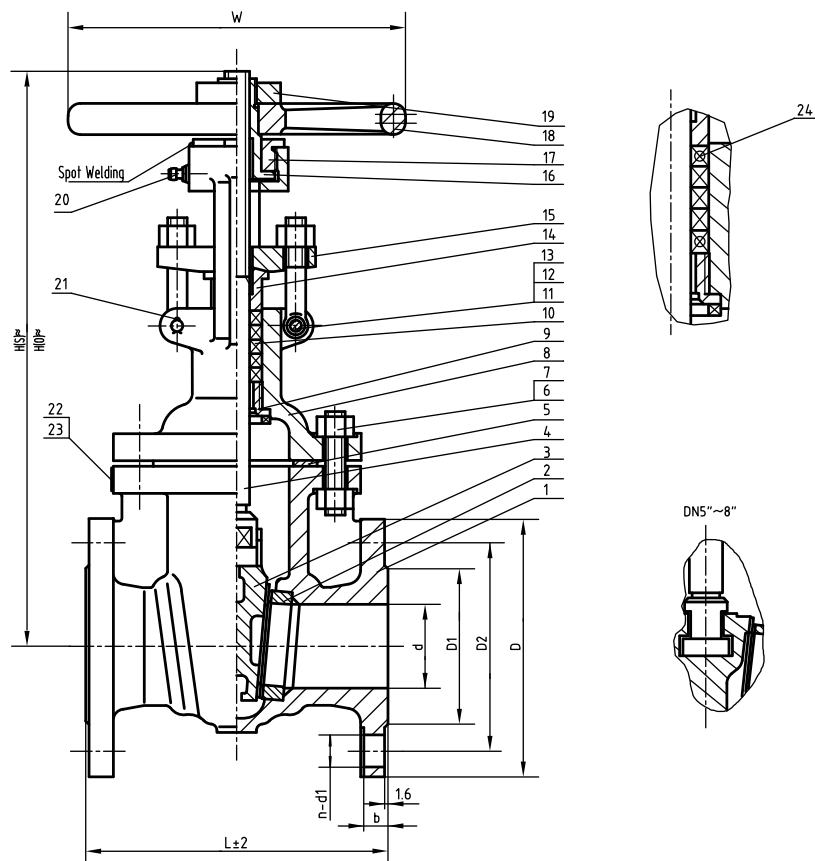
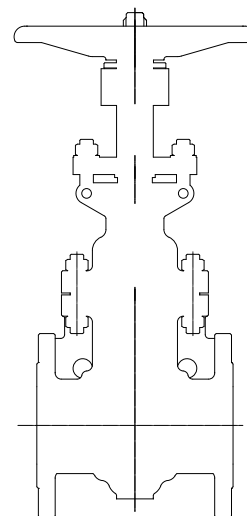

Componentes		
Pos.	Denominación	Material
1	Cuerpo	ASTM A216 WCB
2	Asientos	ASTM A105 +Stellite
3	Cuña	ASTM A216 WCB
4	Husillo	ASTM A182 F6a
5	Junta	Grafito
6	Tornillo	ASTM A193 B7M
7	Tuerca	ASTM A194 2HM
8	Tapa	ASTM A216 WCB
9	Cierre trasero	ASTM A276 410
10	Empaquetadura	Grafito
11	Pasador	ASTM A29 1035
12	Tornillo de ojo	ASTM A193 B7
13	Tuerca	ASTM A194 2H
14	Prensaestopas	ASTM A276 410
15	Brida prensaestopas	ASTM A216 WCB
16	Tuerca husillo	ASTM A439 D-2
17	Tuerca retén	ASTM A29 1035
18	Volante	ASTM A536 60-40-18
19	Tuerca volante	ASTM A29 1035
20	Engrasador	ASTM A36
21	Pasador partido	ASTM A36
22	Placa identificación	ASTM A240 321
23	Remache	ASTM A276 321
24	Empaquetadura	Grafito + Acero inox.

FIG. GA01011XU - COMPUERTA WCB/F6 XU TRIM N° 8 - 150LBS RF

Código	DN	d	D1	D2	D	b	n-d1	L	W	H		Peso (kg)
										cerrada	abierta	
010101302721562	2"	51	92	120.5	152	17.5	4 - Ø19	178	200	343	406	18.3
010101302721563	2.1/2"	64	105	139.5	178	19.5	4 - Ø19	190	200	374	451	24.6
010101302721564	3"	76	127	152.5	190	20.5	4 - Ø19	203	250	428	517	30.4
010101302721565	4"	102	157	190.5	229	24	8 - Ø19	229	250	501	616	45.9
010101302722934	5"	127	186	216	254	24	8 - Ø22	254	300	563	704	62
010101302721566	6"	152	216	241.5	279	26	8 - Ø22	267	300	626	794	72.5
010101302721567	8"	203	270	298.5	343	29	8 - Ø22	292	350	765	985	111

COMPUERTA 150LBS 2" - 8" BW

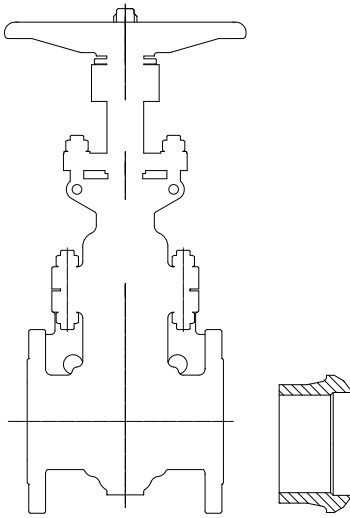

COMPUERTA Butt Weld Fig. GA01013XU		Clase: 150LBS
VÁLVULA COMPUERTA ACERO CARBONO 150LBS BW		
Especificaciones		
Material	Acero carbono ASTM A216 WCB ¹	
Diseño	API 600	
Conexiones	Butt Weld según ASME B16.25	
Longitud	ASME B16.10	
Inspección y Pruebas	API 598	
NACE MR 01-75	Bajo demanda	
Aplicaciones	Refinerías, Petroquímica, Química, Metalurgia, Papel, Farmacéuticas...	
¹ Ver lista de materiales estándar		

Componentes		
Pos.	Denominación	Material
1	Cuerpo	ASTM A216 WCB
2	Asientos	ASTM A105 +Stellite
3	Cuña	ASTM A216 WCB +Stellite
4	Husillo	ASTM A182 F6a CL2
5	Junta	Grafito/Acero inox.
6	Tornillo	ASTM A193 B7
7	Tuerca	ASTM A194 2H
8	Tapa	ASTM A216 WCB
9	Cierre trasero	ASTM A276 410
10	Empaquetadura	Grafito
11	Pasador	ASTM A29 1035
12	Tornillo	ASTM A193 B7
13	Tuerca	ASTM A194 2H
14	Prensaestopas	ASTM A276 410
15	Brida prensaestopas	ASTM A216 WCB
16	Tuerca husillo	ASTM A439 D-2
17	Tuerca retén	ASTM A29 1035
18	Volante	ASTM A536 60-40-18
19	Tuerca volante	ASTM A29 1035
20	Engrasador	ASTM A36
21	Pasador partido	ASTM A36
22	Chapa identificación	ASTM A240 321
23	Remache	ASTM A276 321
24	Empaquetadura	Grafito/Acero inox.
25	Lengüeta	ASTM A105

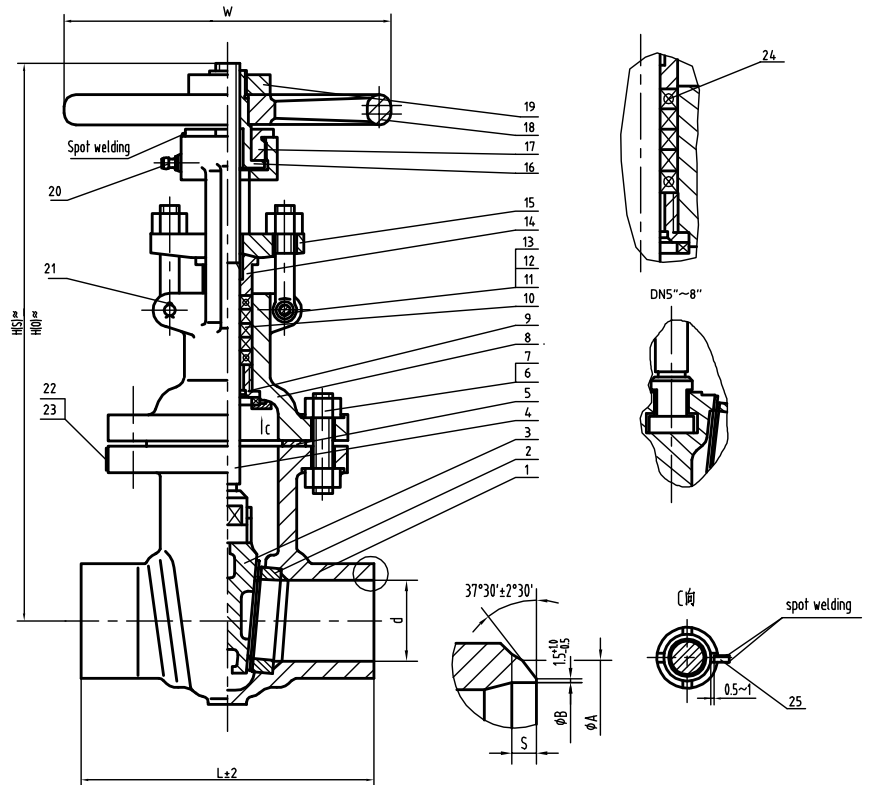
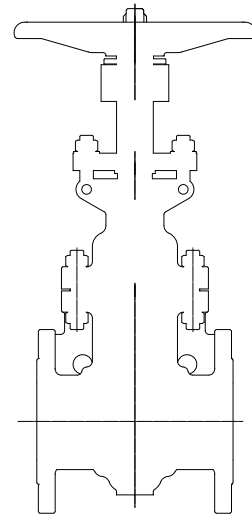

FIG. GA01013XU - COMPUERTA WCB/F6 XU TRIM N° 8 - 150LBS BW

DN	d	A	SCH 10		SCH 20		SCH 30		SCH 40		SCH 60		SCH 80		SCH STD		SCH XS		L	W	H(S)	H(O)	Peso (kg)
			B	S	B	S	B	S	B	S	B	S	B	S	B	S	B	S					
2"	51	62	55	5			54	5	52.5	6			49	9	52.5	6	49	9	216	200	343	406	15.1
2.1/2"	64	75	67	5			6.5	8	62.5	8			59	11	62.5	8	59	11	241	200	374	451	20.2
3"	76	91	83	5			79.5	8	78	9			73.5	12	78	9	73.5	12	282	250	428	517	25.3
4"	102	117	108	5			104.5	8	102.5	10			97	13	102.5	10	97	13	305	250	501	616	37.9
5"	127	144	134.5	6					128	10			122	15	128	10	122	15	381	300	563	704	55.4
6"	152	172	161.5	6					154	11			146.5	17	154	11	146.5	17	403	300	626	794	63.7
8"	203	223	211.5	6	206.5	10	205	11	203	13	198.5	16	193.5	20	203	13	193.5	20	419	350	765	985	96.9

VÁLVULAS FUNDIDAS ANSI

COMPUERTA 150LBS 10" - 18" BRIDAS



COMPUERTA Fig. GA01011XU		Clase: 150LBS
VÁLVULA COMPUERTA ACERO CARBONO 150LBS BRIDAS		
Especificaciones		
Material	Acero carbono ASTM A216 WCB ¹	
Diseño	API 600	
Conexiones	Bridas según ASME B16.5 RF	
Longitud	ASME B16.10	
Inspección y Pruebas	API 598	
NACE MR 01-75	Bajo demanda	
Aplicaciones	Refinerías, Petroquímica, Química, Metalurgia, Papel, Farmacéuticas...	
¹ Ver lista de materiales estándar		

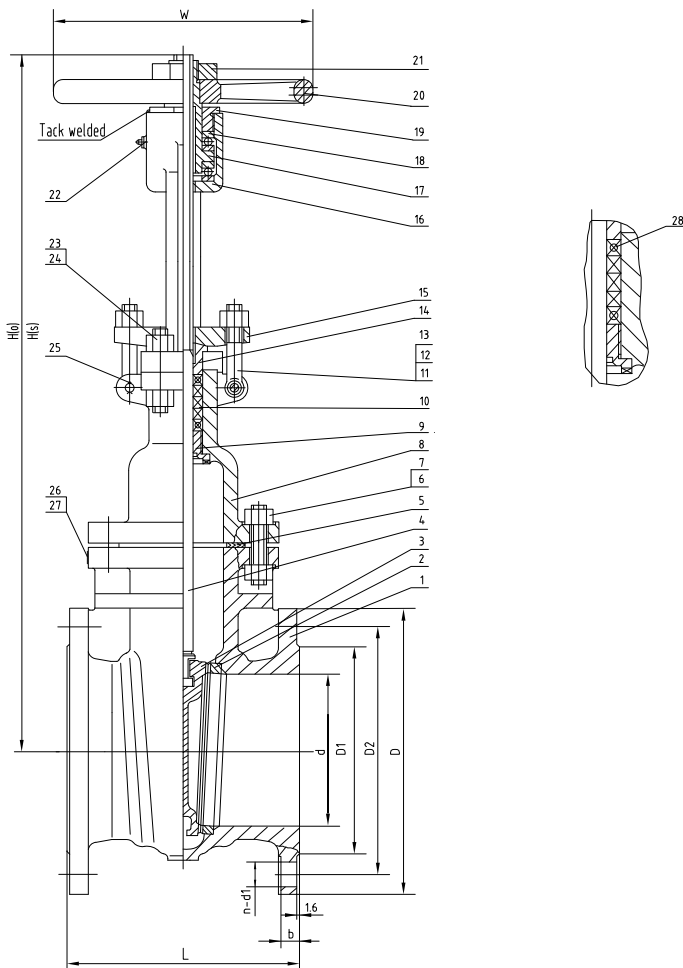

Componentes		
Pos.	Denominación	Material
1	Cuerpo	ASTM A216 WCB
2	Asientos	ASTM A105 +Stellite
3	Cuña	ASTM A216 WCB +ER410
4	Husillo	ASTM A182 F6a
5	Junta	Grafito
6	Tornillo	ASTM A193 B7
7	Tuerca	ASTM A194 2H
8	Tapa	ASTM A216 WCB
9	Cierre trasero	ASTM A276 410
10	Empaquetadura	Grafito
11	Pasador	ASTM A29 1035
12	Tornillo de ojo	ASTM A193 B7
13	Tuerca	ASTM A194 2H
14	Prensaestopas	ASTM A276 410
15	Brida prensaestopas	ASTM A216 WCB
16	Puente	ASTM A216 WCB
17	Tuerca husillo	ASTM A439 D-2
18	Casquillo	
19	Tuerca retén	ASTM A29 1035
20	Volante	ASTM A536 60-40-18
21	Tuerca volante	ASTM A29 1035
22	Engrasador	ASTM A36
23	Pasador	ASTM A36
24	Tuerca	ASTM A194 2H
25	Tornillo	ASTM A193 B7
26	Placa identificación	ASTM A240 321
27	Remache	ASTM A276 321
28	Empaquetadura	Grafito + Ac. inox.

FIG. GA01011XU - COMPUERTA WCB/F6 XU TRIM N° 8 - 150LBS RF

Código	DN	d	D1	D2	D	b	n-d1	L	W	H		Peso (kg)
										cerrada	abierta	
010101302721558	10"	254	324	362	406	31	12-25	330	450	909	1182	179
-	12"	305	381	432	483	32	12-25	356	500	1048	1373	262
-	14"	337	413	476	533	35	12-29	381	560	1146	1506	332
-	16"	387	470	540	597	37	16-29	406	640	1300	1710	429
-	18"	438	533	578	635	40	16-32	432	720	1428	1887	523

COMPUERTA 150LBS 10" - 18" BW

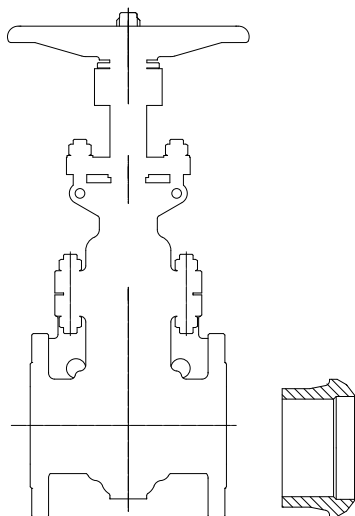

COMPUERTA Butt Weld Fig. GA01013XU		Clase: 150LBS
VÁLVULA COMPUERTA ACERO CARBONO 150LBS BW		
Especificaciones		
Material	Acero carbono ASTM A216 WCB ¹	
Diseño	API 600	
Conexiones	Butt Weld según ASME B16.25	
Longitud	ASME B16.10	
Inspección y Pruebas	API 598	
NACE MR 01-75	Bajo demanda	
Aplicaciones	Refinerías, Petroquímica, Química, Metalurgia, Papel, Farmacéuticas...	
¹ Ver lista de materiales estándar		

Componentes		
Pos.	Denominación	Material
1	Cuerpo	ASTM A216 WCB
2	Asientos	ASTM A105 +Stellite
3	Cuña	ASTM A216 WCB +Stellite
4	Husillo	ASTM A182 F6a CL2
5	Junta	Grafito/Acero inox.
6	Tornillo	ASTM A193 B7
7	Tuerca	ASTM A194 2H
8	Tapa	ASTM A216 WCB
9	Cierre trasero	ASTM A276 410
10	Empaquetadura	Grafito
11	Pasador	ASTM A29 1035
12	Tornillo	ASTM A193 B7
13	Tuerca	ASTM A194 2H
14	Prensaestopas	ASTM A276 410
15	Brida prensaestopas	ASTM A216 WCB
16	Puente	ASTM A216 WCB
17	Tuerca husillo	ASTM A439 D-2
18	Casquillo	
19	Tuerca retén	ASTM A29 1035
20	Volante	ASTM A536 60-40-18
21	Tuerca volante	ASTM A29 1035
22	Engrasador	ASTM A36
23	Tornillo	ASTM A193 B7
24	Tuerca	ASTM A194 2H
25	Pasador partido	ASTM A36
26	Chapa identificación	ASTM A240 321
27	Remache	ASTM A276 321
28	Empaquetadura	Grafito/Acero inox.

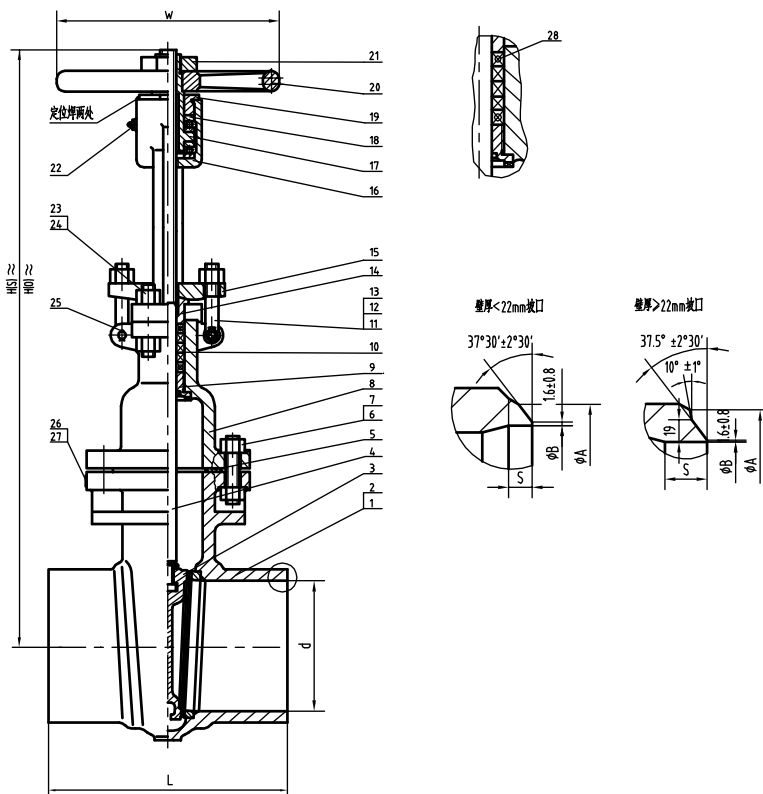

FIG. GA01013XU - COMPUERTA WCB/F6 XU TRIM N° 8 - 150LBS BW

DN	d	A	SCH 10		SCH 20		SCH 30		SCH 40		SCH 60		SCH 80		SCH STD		SCH XS		L	W	H(S)	H(O)	Peso (kg)
			B	S	B	S	B	S	B	S	B	S	B	S	B	S	B	S					
10"	254	278	264.5	7	260.5	10	257.5	12	254.5	14	247.5	20	243	23	254.5	14	247.5	20	457	450	909	1182	158
12"	305	329	314.5	7	311	10	307	13	303	16	295.5	22	289	27	304.5	15	298.5	20	502	500	104.8	1373	231
14"	337	362	343	10	340	12	336.5	15	333.5	17	325.5	23	317.5	29	336.5	15	330	20	572	560	1146	1506	328
16"	387	413	395.5	10	390.5	12	387.5	15	381	20	373	25	363.5	33	387.5	15	381	20	610	640	1300	1710	382
18"	438	464	444.5	10	441	12	434.5	17	428.5	22	419	29	409.5	36	438	15	431.5	20	660	720	1428	1887	485

VÁLVULAS FUNDIDAS ANSI

COMPUERTA 150LBS 10" - 24" BRIDAS CON REDUCTOR

COMPUERTA Fig. GA01011XU		Clase: 150LBS
VÁLVULA COMPUERTA ACERO CARBONO 150LBS BRIDAS		
Especificaciones		
Material	Acero carbono ASTM A216 WCB ¹	
Diseño	API 600	
Conexiones	Bridas según ASME B16.5 RF	
Longitud	ASME B16.10	
Inspección y Pruebas	API 598	
NACE MR 01-75	Bajo demanda	
Aplicaciones	Refinerías, Petroquímica, Química, Metalurgia, Papel, Farmacéuticas...	
¹ Ver lista de materiales estándar		

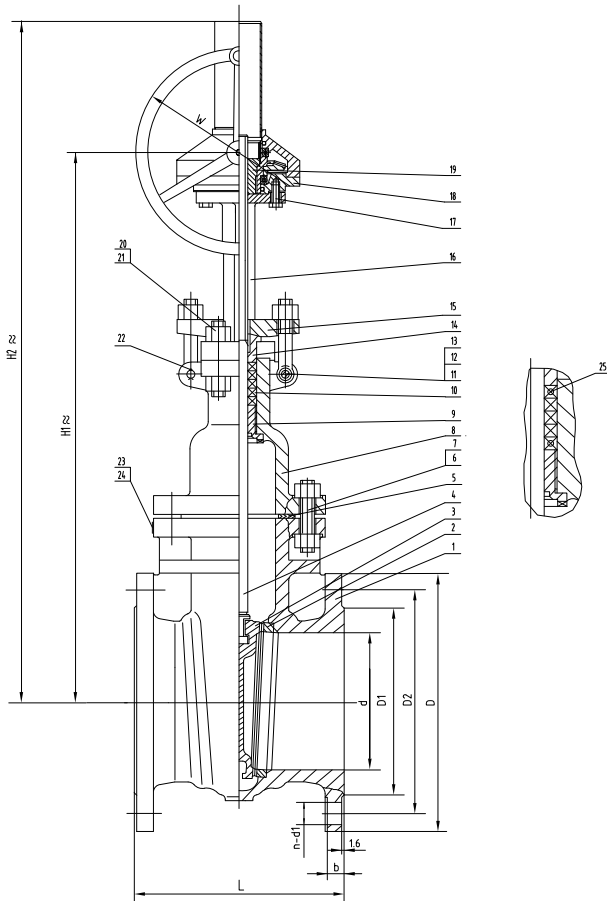
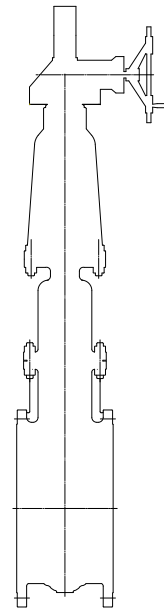

Componentes		
Pos.	Denominación	Material
1	Cuerpo	ASTM A216 WCB
2	Asientos	ASTM A105 +Stellite
3	Cuña	ASTM A216 WCB +ER410
4	Husillo	ASTM A182 F6a
5	Junta	Acero inox. / Grafito
6	Espárrago	ASTM A193 B7
7	Tuerca	ASTM A194 2H
8	Tapa	ASTM A216 WCB
9	Cierre trasero	ASTM A276 410
10	Empaquetadura	Grafito
11	Pasador	ASTM A29 1035
12	Tornillo de ojo	ASTM A193 B7
13	Tuerca	ASTM A194 2H
14	Prensaestopas	ASTM A276 410
15	Brida prensaestopas	ASTM A216 WCB
16	Puente	ASTM A216 WCB
17	Tornillo	Acero carbono
18	Reductor manual	
19	Tuerca husillo	ASTM A439 D-2
20	Tornillo	ASTM A193 B7
21	Tuerca	ASTM A194 2H
22	Pasador	Acero carbono
23	Remache	ASTM A276 321
24	Placa identificación	ASTM A240 321

FIG. GA01011XU - COMPUERTA WCB/F6 XU TRIM N° 8 - 150LBS RF

Código	DN	d	D1	D2	D	b	n-d1	L	W	H1	H2	Peso (kg)
010101302722997	10"	254	324	362	406	31	12-25	330	310			
010101302721595	12"	305	381	432	483	32	12-25	356	310	1056	1416	267
010101302721618	14"	337	413	476	533	35	12-29	381	310	1150	1550	332
010101302721600	16"	387	470	540	597	37	16-29	406	460	1280	1730	423
010101302721602	18"	438	533	578	635	40	16-32	432	460	1416	1916	529
010101302721589	20"	489	584	635	699	43	20-32	457	610	1553	2107	622
010101302720889	22"	540	641	692	750	46	20-35	508	610	1830	2470	685
010101302721596	24"	591	692	749.5	813	48	20-35	508	610	1835	2490	902

COMPUERTA 150LBS 26" - 48" BRIDAS CON REDUCTOR

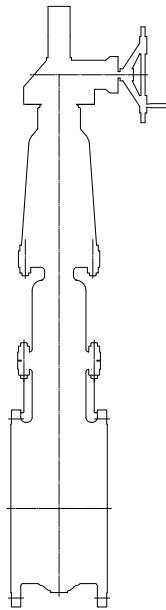

COMPUERTA Fig. GA01011XU		Clase: 150LBS
VÁLVULA COMPUERTA ACERO CARBONO 150LBS BRIDAS		
Especificaciones		
Material	Acero carbono ASTM A216 WCB ¹	
Diseño	API 600	
Conexiones	Bridas según ASME B16.47 Serie B ²	
Longitud	ASME B16.10	
Inspección y Pruebas	API 598	
NACE MR 01-75	Bajo demanda	
Aplicaciones	Refinerías, Petroquímica, Química, Metalurgia, Papel, Farmacéuticas...	
¹ Ver lista de materiales estándar ² Excepto 42" y 48" (ASME B16.47 Serie A)		

Componentes		
Pos.	Denominación	Material
1	Cuerpo	ASTM A216 WCB
2	Cuña	A216 WCB / 13Cr.
3	Asientos	ASTM A105 / Stellite
4	Husillo	ASTM A182 F6a
5	Junta	Grafito reforzado
6	Tapa	ASTM A216 WCB
7	Tornillo	ASTM A193 B7
8	Tuerca	ASTM A194 2H
9	Cierre trasero	ASTM A182 F6a
10	Empaquetadura	Grafito
11	Prensaestopas	ASTM A276 410
12	Brida prensaestopas	Acero carbono
13	Tornillo	ASTM A193 B7
14	Tuerca	ASTM A194 2H
15	Tornillos	ASTM A193 B7
16	Tuercas	ASTM A194 2H
17	Puente	ASTM A216 WCB
18	Tornillo	ASTM A193 B7
19	Tuerca husillo	
20	Reductor manual	
21	Tuerca	ASTM A276 410
22	Tornillo	Acero carbono
24	Placa identificación	Acero inoxidable
25	Remache	Acero inoxidable

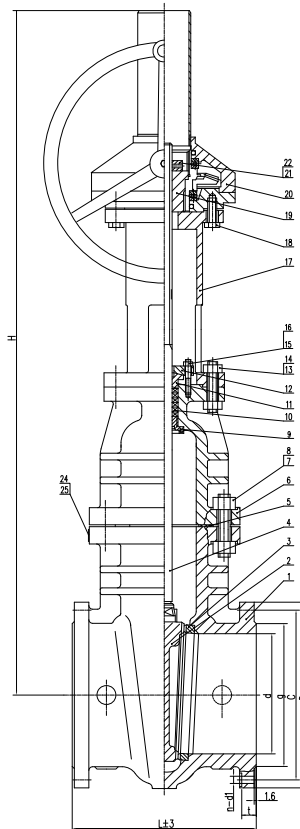

FIG. GA01011XU - COMPUERTA WCB/F6 XU TRIM N° 8 - 150LBS RF

Código	DN	d	L (RF)	W	H		g	C	D	t	n	d1	Peso (kg)
					cerrada	abierta							
-	26"	635	559	610	2.250	2.950	711	745	786	41	36	22	1.415
-	28"	686	610	610	2.420	3.175	762	795	837	44	40	22	1.637
010101302722747	30"	736	610	610	2.625	3.435	813	846	887	44	44	22	2.250
-	32"	781	660	610	2.680	3.540	864	900	941	46	48	22	2.820
-	34"	832	711	760	2.827	3.934	921	957.5	1.005	49.5	40	25	3.013
010101302720969	36"	876	711	610	2.800	3.765	972	1.010	1.055	52	44	25	3.350
-	38"	928	812	610	3.020	4.100	1.022	1.070	1.124	54	44	28	3.920
-	40"	978	812	610	3.200	4.400	1.080	1.121	1.175	56	44	28	4.436
-	42"	1.022	787				1.194	1.257	1.346	97	36	42	5.750
-	48"	1.168	864				1.359	1.422	1.511	108	44	42	6.830

VÁLVULAS FUNDIDAS ANSI

COMPUERTA 300LBS 2" - 8" BRIDAS

COMPUERTA Fig. GA03011XU		Clase: 300LBS
VÁLVULA COMPUERTA ACERO CARBONO 300LBS BRIDAS		
Especificaciones		
Material	Acero carbono ASTM A216 WCB ¹	
Diseño	API 600	
Conexiones	Bridas según ASME B16.5 RF	
Longitud	ASME B16.10	
Inspección y Pruebas	API 598	
NACE MR 01-75	Bajo demanda	
Aplicaciones	Refinerías, Petroquímica, Química, Metalurgia, Papel, Farmacéuticas...	
¹ Ver lista de materiales estándar		

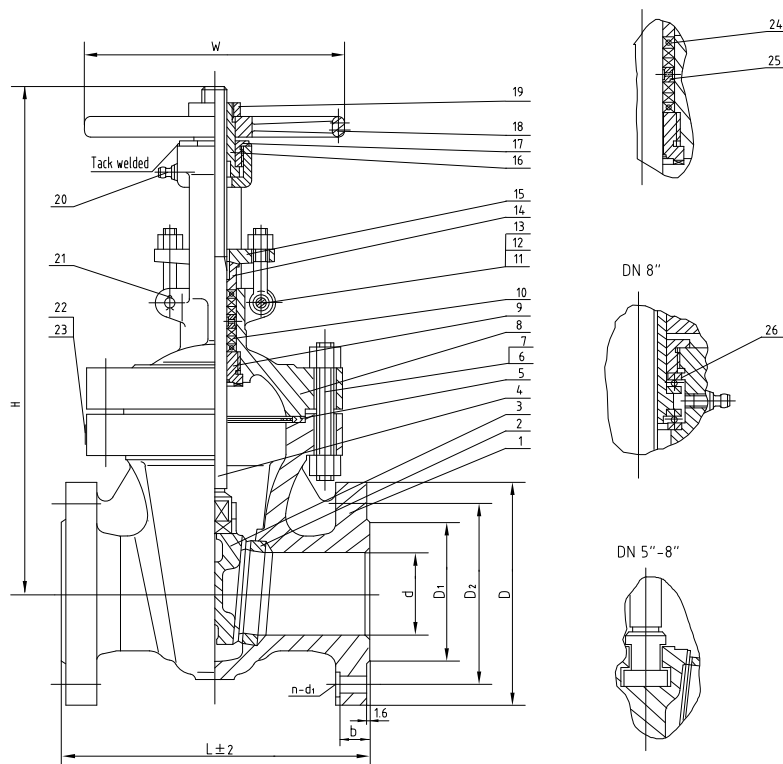
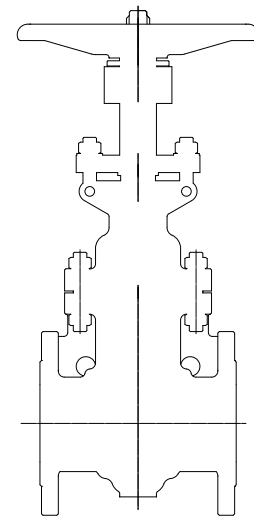

Componentes		
Pos.	Denominación	Material
1	Cuerpo	ASTM A216 WCB
2	Asientos	ASTM A105 +Stellite
3	Cuña	ASTM A216 WCB
4	Husillo	ASTM A182 F6a
5	Junta	Espirometálica Grafito/Ac.inox.
6	Tornillo	ASTM A193 B7
7	Tuerca	ASTM A194 2H
8	Tapa	ASTM A216 WCB
9	Cierre trasero	ASTM A276 410
10	Empaquetadura	Grafito
11	Pasador	ASTM A29 1035
12	Tornillo de ojo	ASTM A193 B7
13	Tuerca	ASTM A194 2H
14	Prensaestopas	ASTM A276 410
15	Brida prensaestopas	ASTM A216 WCB
16	Tuerca husillo	ASTM A439 D-2
17	Tuerca retén	ASTM A29 1035
18	Volante	ASTM A536 60-40-18
19	Tuerca volante	ASTM A29 1035
20	Engrasador	ASTM A36
21	Pasador	ASTM A36
22	Placa identificación	ASTM A240 321
23	Remache	ASTM A276 321
24	Empaquetadura	Grafito + Acero inox.
25	Linterna	ASTM A276 410
26	Casquillo	

FIG. GA03011XU - COMPUERTA WCB/F6 XU TRIM N° 8 - 300LBS RF

Código	DN	d	D1	D2	D	b	n-d1	L	W	H		Peso (kg)
										cerrada	abierta	
010101302721615	2"	51	92	127	165	23	8 - Ø19	216	200	370	433	25.8
010101302721626	2.1/2"	64	105	149	190	26	8 - Ø22	241	250	399	476	35.4
010101302721617	3"	76	127	168.5	210	29	8 - Ø22	283	250	462	551	47.2
010101302721608	4"	102	157	200	254	32	8 - Ø22	305	300	534	649	72.9
-	5"	127	186	235	279	35	8 - Ø22	381	350	604	745	101
010101302721619	6"	152	216	270	318	37	12 - Ø22	403	350	671	838	139
010101302721620	8"	203	270	330	381	42	12 - Ø25	419	450	814	1033	207

COMPUERTA 300LBS 2" - 8" BW

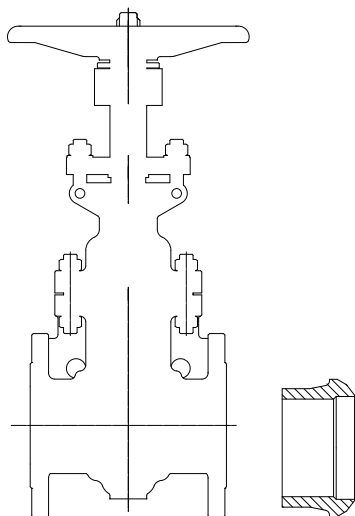

COMPUERTA Butt Weld Fig. GA03013XU		Clase: 300LBS
VÁLVULA COMPUERTA ACERO CARBONO 300LBS BW		
Especificaciones		
Material	Acero carbono ASTM A216 WCB ¹	
Diseño	API 600	
Conexiones	Butt Weld según ASME B16.25	
Longitud	ASME B16.10	
Inspección y Pruebas	API 598	
NACE MR 01-75	Bajo demanda	
Aplicaciones	Refinerías, Petroquímica, Química, Metalurgia, Papel, Farmacéuticas...	
¹ Ver lista de materiales estándar		

Componentes		
Pos.	Denominación	Material
1	Cuerpo	ASTM A216 WCB
2	Asientos	ASTM A105 +Stellite
3	Cuña	ASTM A216 WCB +Stellite
4	Husillo	ASTM A182 F6a CL2
5	Junta	Grafito/Acero inox.
6	Tornillo	ASTM A193 B7
7	Tuerca	ASTM A194 2H
8	Tapa	ASTM A216 WCB
9	Cierre trasero	ASTM A276 410
10	Empaquetadura	PTFE
11	Pasador	ASTM A29 1035
12	Tornillo	ASTM A193 B7
13	Tuerca	ASTM A194 2H
14	Prensaestopas	ASTM A276 410
15	Brida prensaestopas	ASTM A216 WCB
16	Tuerca husillo	ASTM A439 D-2
17	Tuerca retén	ASTM A29 1035
18	Volante	ASTM A536 60-40-18
19	Tuerca volante	ASTM A29 1045
20	Engrasador	ASTM A36
21	Pasador partido	ASTM A36
22	Chapa identificación	ASTM A240 321
23	Remache	ASTM A276 321
24	Empaquetadura	Grafito/Acero inox.
25	Linterna	ASTM A276 410
26	Lengüeta	ASTM A105
27	Cojinete	

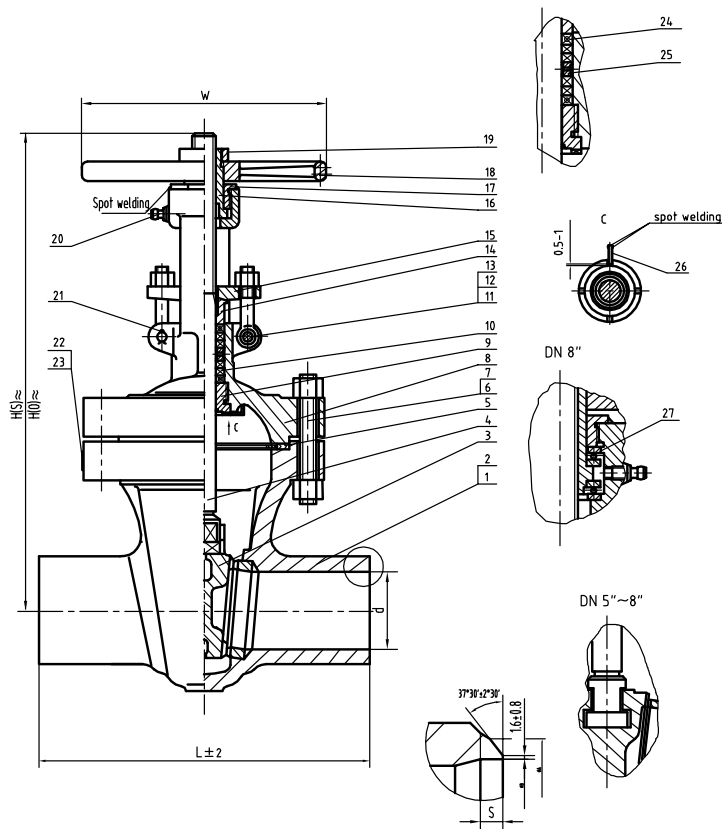

FIG. GA03013XU - COMPUERTA WCB/F6 XU TRIM N° 8 - 300LBS BW

DN	d	A	SCH 40		SCH 80		L	W	H(S)	H(O)	Peso (kg)
			B	T	B	T					
2"	51	62	52.5	6	49	9	200	216	370	433	25.8
2.1/2"	64	75	62.5	8	59	11	250	241	399	476	26.5
3"	76	91	78	9	73.5	12	250	283	462	551	44.3
4"	102	117	102	10	97	13	300	305	534	649	68
5"	127	144	128	10	122	15	350	381	604	745	92.9
6"	152	172	154	11	146.5	17	350	403	671	838	106.2
8"	203	223	203	13	193.5	20	450	419	814	1033	156.8

VÁLVULAS FUNDIDAS ANSI

COMPUERTA 300LBS 10" - 14" BRIDAS

COMPUERTA Fig. GA03011XU		Clase: 300LBS
VÁLVULA COMPUERTA ACERO CARBONO 300LBS BRIDAS		
Especificaciones		
Material	Acero carbono ASTM A216 WCB ¹	
Diseño	API 600	
Conexiones	Bridas según ASME B16.5 RF	
Longitud	ASME B16.10	
Inspección y Pruebas	API 598	
NACE MR 01-75	Bajo demanda	
Aplicaciones	Refinerías, Petroquímica, Química, Metalurgia, Papel, Farmacéuticas...	
¹ Ver lista de materiales estándar		

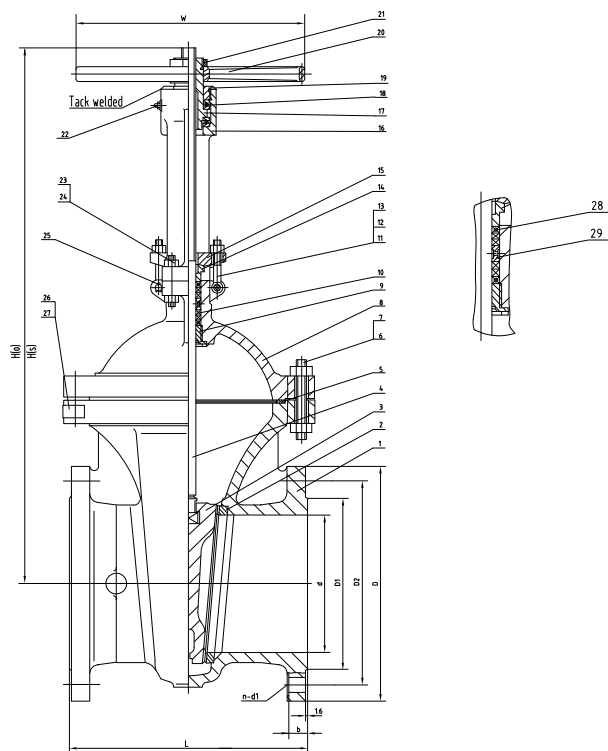
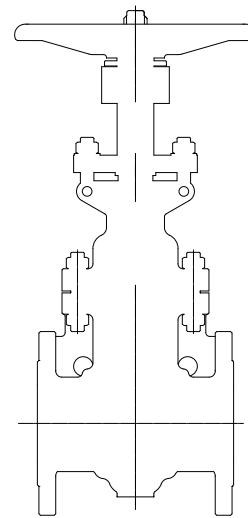

Componentes		
Pos.	Denominación	Material
1	Cuerpo	ASTM A216 WCB
2	Asientos	ASTM A105 +Stellite
3	Cuña	ASTM A216 WCB +ER410
4	Husillo	ASTM A182 F6a
5	Junta	Ac. inox / Grafito
6	Espárrago	ASTM A193 B7
7	Tuerca	ASTM A194 2H
8	Tapa	ASTM A216 WCB
9	Cierre trasero	ASTM A276 410
10	Empaquetadura	Grafito
11	Pasador	ASTM A29 1035
12	Tornillo de ojo	ASTM A193 B7
13	Tuerca	ASTM A194 2H
14	Prensaestopas	ASTM A276 410
15	Brida prensaestopas	ASTM A216 WCB
16	Puente	ASTM A216 WCB
17	Tuerca husillo	ASTM A439 D-2
18	Casquillo	
19	Tuerca retén	ASTM A29 1035
20	Volante	ASTM A536 60-40-18
21	Tuerca volante	ASTM A29 1035
22	Lubricador	ASTM A36
23	Tuerca	ASTM A194 2H
24	Espárrago	ASTM A193 B7
25	Pasador	ASTM A36
26	Placa identificación	ASTM A240 321
27	Remache	ASTM A276 321
28	Empaquetadura	Ac. inox / Grafito
29	Linterna	ASTM A276 410

FIG. GA03011XU - COMPUERTA WCB/F6 XU TRIM N° 8 - 300LBS RF

Código	DN	d	D1	D2	D	b	n-d1	L	W	H(s)	H(o)	Peso (kg)
010101302721621	10"	254	324	387.5	445	48	16-29	457	500	960	1234	311
-	12"	305	381	451	521	51	16-32	502	560	1092	1417	427
-	14"	337	413	514.5	584	54	20-32	762	640	1217	1576	616

COMPUERTA 300LBS 10" - 24" BRIDAS CON REDUCTOR

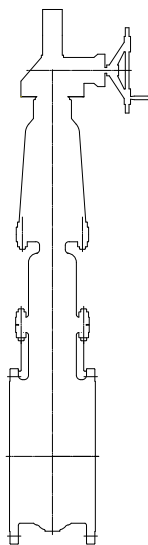

COMPUERTA Fig. GA03011XU		Clase: 300LBS
VÁLVULA COMPUERTA ACERO CARBONO 300LBS BRIDAS		
Especificaciones		
Material	Acero carbono ASTM A216 WCB ¹	
Diseño	API 600	
Conexiones	Bridas según ASME B16.5 RF	
Longitud	ASME B16.10	
Inspección y Pruebas	API 598	
NACE MR 01-75	Bajo demanda	
Aplicaciones	Refinerías, Petroquímica, Química, Metalurgia, Papel, Farmacéuticas...	
¹ Ver lista de materiales estándar		

Componentes		
Pos.	Denominación	Material
1	Cuerpo	ASTM A216 WCB
2	Asientos	ASTM A105 +Stellite
3	Cuña	ASTM A216 WCB +ER410
4	Husillo	ASTM A182 F6a
5	Junta	Espirometalica Grafito/SS
6	Tornillo	ASTM A193 B7
7	Tuerca	ASTM A194 2H
8	Tapa	ASTM A216 WCB
9	Cierre trasero	ASTM A276 410
10	Empaquetadura	Grafito
11	Pasador	ASTM A29 1035
12	Tornillo de ojo	ASTM A193 B7
13	Tuerca	ASTM A194 2H
14	Prensaestopas	ASTM A276 410
15	Brida prensaestopas	ASTM A216 WCB
16	Puente	ASTM A216 WCB
17	Tornillo	ASTM A193 B7
18	Reductor manual	
19	Tuerca husillo	ASTM A439 D-2
20	Tuerca	ASTM A194 2H
21	Tornillo	ASTM A193 B7
22	Pasador	ASTM A36
23	Placa identificación	ASTM A240 321
24	Remache	ASTM A276 321
25	Empaquetadura	Grafito/Acero inox.
26	Linterna	ASTM A276 410

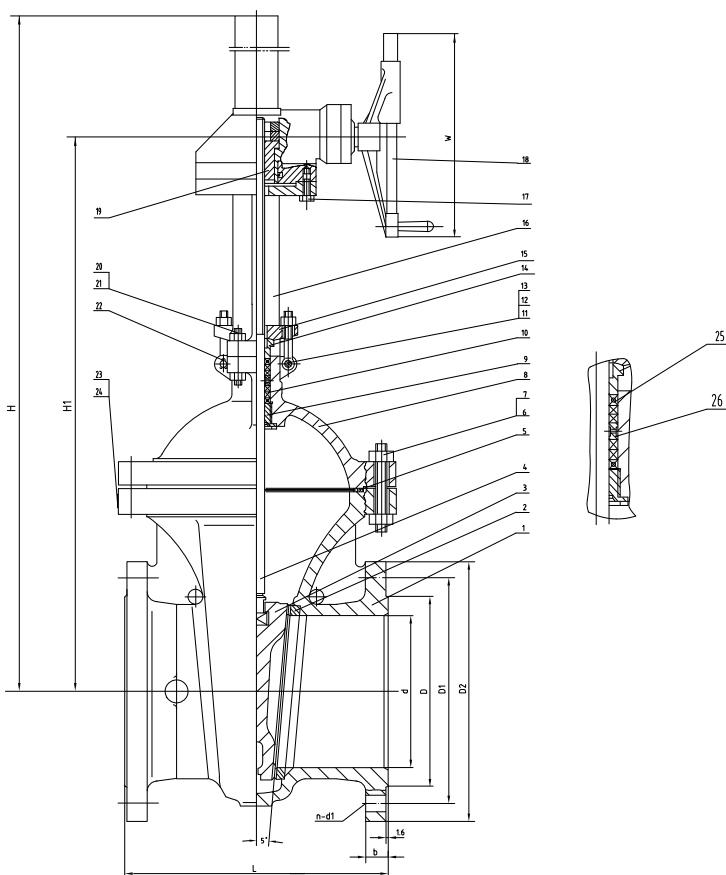

FIG. GA03011XU - COMPUERTA WCB/F6 XU TRIM N° 8 - 300LBS RF

Código	DN	d	D1	D2	D	b	n-d1	L	W	H1	H	Peso (kg)
010101302722811	10"	254	324	387.5	444	48	16-29	457	310	977	1312	331
010101302721450	12"	305	381	451	521	51	16-32	502	310	1096	1466	407
010101302722993	14"	337	413	514.5	584	54	20-32	762	460	1196	1596	615
010101302722911	16"	387	470	571.5	648	58	20-35	838	460	1339	1789	767
010101302722871	18"	432	533	628.5	711	61	24-35	914	610	1461	1951	969
010101302722765	20"	483	584	686	775	64	24-35	991	610	1601	2151	1211
010101302723485	24"	584	692	813	914	70	24-41	1143	610	1921	2576	1929

VÁLVULAS FUNDIDAS ANSI

COMPUERTA 300LBS 26" - 48" BRIDAS CON REDUCTOR

COMPUERTA		Clase: 300LBS
VÁLVULA COMPUERTA ACERO CARBONO 300LBS BRIDAS		
Especificaciones		
Material	Acero carbono ASTM A216 WCB ¹	
Diseño	API 600	
Conexiones	Bridas según ASME B16.47-A RF	
Longitud	ASME B16.10	
Inspección y Pruebas	API 598	
NACE MR 01-75	Bajo demanda	
Aplicaciones	Refinerías, Petroquímica, Química, Metalurgia, Papel, Farmacéuticas...	
¹ Ver lista de materiales estándar		

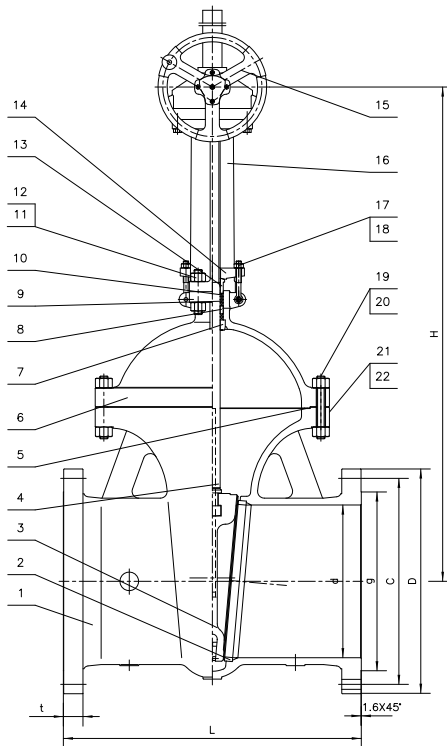
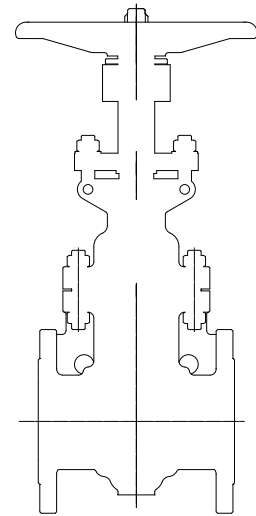

Pos.	Denominación	Componentes	
		Cant.	Material
1	Cuerpo	1	ASTM A216 WCB
2	Asientos	2	ASTM A105 +Stellite
3	Cuña	1	ASTM A216 WCB +13Cr
4	Husillo	1	ASTM A182 F6a
5	Junta	1	1010 / Grafito
6	Tapa	1	ASTM A216 WCB
7	Back seat	1	ASTM A276 304
8	Linterna	1	ASTM A276 410
9	Empaquetadura	7-8	Grafito
10	Empaquetadura	2	Grafito flexible
11	Tornillo	4	ASTM A193 B7
12	Tuerca	8	ASTM A194 2H
13	Prensaestopos	1	ASTM A276 410
14	Brida prensaestopos	1	ASTM A216 WCB
15	Reductor	1	
16	Puente	1	ASTM A216 WCB
17	Tornillo de ojo	2	ASTM A193 B7
18	Tuerca	2	ASTM A194 2H
19	Pasador	2	ASTM A108 1035
20	Tornillo		ASTM A193 B7
21	Tuerca		ASTM A194 2H
22	Remache	2	304SS
23	Placa identificación	2	304SS

COMPUERTA WCB/F6 XU TRIM N° 8 - 300LBS RF

Código	DN	d	L	D	c	g	t	n	d1	H	Peso (kg)
-	26"	635	1.244,6	971,6	876,3	749,3	79,5	28	45	2.110	3.324
-	28"	686	1.346	1.035	939,8	800,1	86	28	45	2.290	3.725
-	30"	737	1.397	1.090	997	857	92,5	28	48	2.429	4.050
-	32"	781	1.524	1.150	1.054	914,4	98,6	28	51	2.542	5.315
-	36"	876	1.727	1.270	1.168,4	1.022	105	32	54	2.790	6.045
-	40"	978	1.854	1.240	1.155,7	1.086	115	32	45	3.013	
-	42"	1.020	1.981	1.290	1.206,5	1.137	120	32	45	3.405	9.500
-	48"	1.168	2.300	1.465	1.371,6	1.302	133	32	51	3.3760	12.530

COMPUERTA 600LBS 2" - 5" BRIDAS

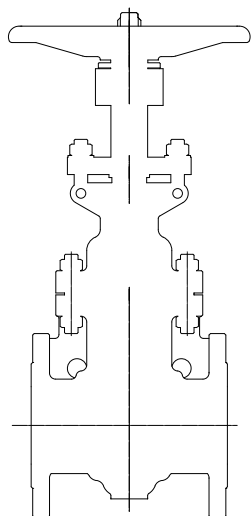

COMPUERTA Fig. GA06011XU		Clase: 600LBS
VÁLVULA COMPUERTA ACERO CARBONO 600LBS BRIDAS		
Especificaciones		
Material	Acero carbono ASTM A216 WCB ¹	
Diseño	API 600	
Conexiones	Bridas según ASME B16.5 RF	
Longitud	ASME B16.10	
Inspección y Pruebas	API 598	
NACE MR 01-75	Bajo demanda	
Aplicaciones	Refinerías, Petroquímica, Química, Metalurgia, Papel, Farmacéuticas...	
¹ Ver lista de materiales estándar		

Componentes		
Pos.	Denominación	Material
1	Cuerpo	ASTM A216 WCB
2	Asientos	ASTM A105 +Stellite
3	Cuña	ASTM A216 WCB +ER410
4	Husillo	ASTM A182 F6a CL2
5	Junta	RTJ o Espirom. Grafito/Ac.inox.
6	Tornillo	ASTM A193 B7
7	Tuerca	ASTM A194 2H
8	Tapa	ASTM A216 WCB
9	Cierre trasero	ASTM A276 410
10	Empaquetadura	Grafito
11	Pasador	Acero carbono
12	Tornillo	ASTM A193 B7
13	Tuerca	ASTM A194 2H
14	Prensaestopas	ASTM A276 410
15	Brida prensaestopas	Acero carbono
16	Tuerca husillo	ASTM A439 D-2
17	Tuerca retén	Acero carbono
18	Volante	Hierro Fundido
19	Tuerca volante	Acero carbono
20	Engrasador	Acero carbono
21	Pasador	Acero carbono
22	Placa identificación	Acero carbono
23	Remache	Acero inoxidable
24	Empaquetadura	Grafito + Acero inox.
25	Linterna	ASTM A276 410
26	Casquillo	

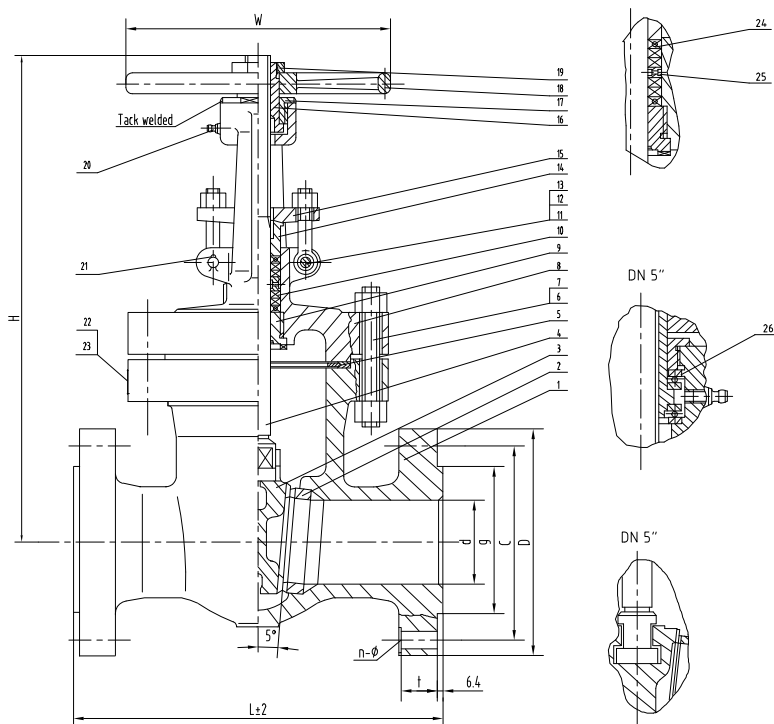

FIG. GA06011XU - COMPUERTA WCB/F6 XU TRIM N° 8 - 600LBS RF

Código	DN	d	g	C	D	t	n-Ø	L	W	H		Peso (kg)
										cerrada	abierta	
010101302721460	2"	51	92	127	165	26	8-Ø19	292	250	374	436	39.3
010101302723545	2.1/2"	64	105	149	190	290	8-Ø22	330	250	422	497	50.9
010101302721616	3"	76	127	168	210	32	8-Ø22	356	300	458	546	67.5
010101302721591	4"	102	157	216	273	38.1	8-Ø25	432	350	574	689	121.2
-	5"	127	186	266.5	330	45	8-Ø29	508	450	645	786	191

VÁLVULAS FUNDIDAS ANSI

COMPUERTA 600LBS 2" - 5" BW

COMPUERTA Fig. GA06013XU		Clase: 600LBS
VÁLVULA COMPUERTA ACERO CARBONO 600LBS BW		
Especificaciones		
Material	Acero carbono ASTM A216 WCB ¹	
Diseño	API 600	
Conexiones	Butt Weld según ASME B16.25	
Longitud	ASME B16.10	
Inspección y Pruebas	API 598	
NACE MR 01-75	Bajo demanda	
Aplicaciones	Refinerías, Petroquímica, Química, Metalurgia, Papel, Farmacéuticas...	
¹ Ver lista de materiales estándar		

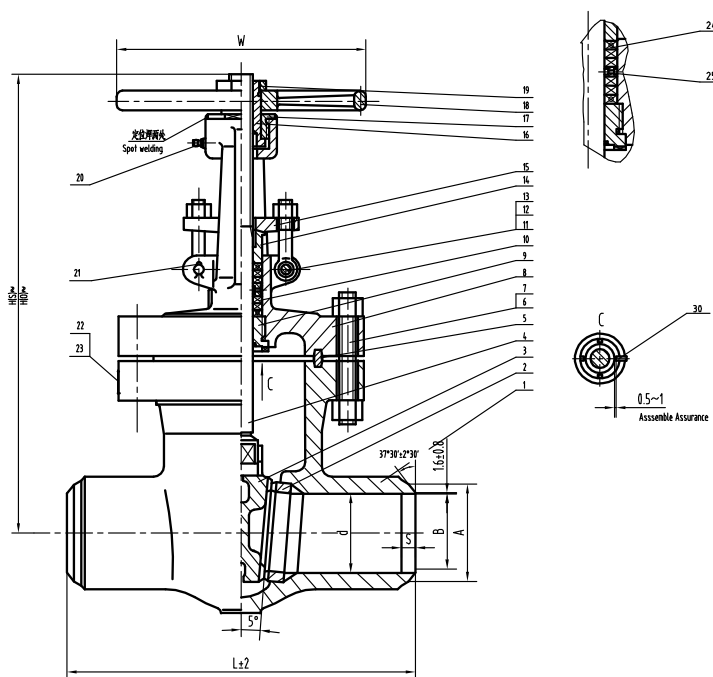
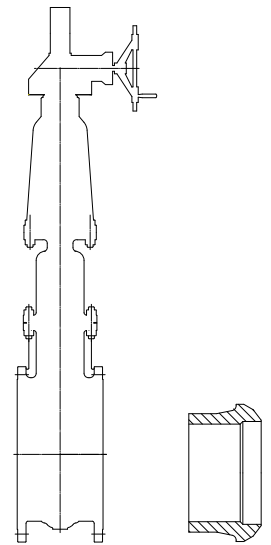

Componentes		
Pos.	Denominación	Material
1	Cuerpo	ASTM A216 WCB
2	Asientos	ASTM A105 +Stellite 6
3	Cuña	ASTM A216 WCB +Stellite 6
4	Husillo	ASTM A182 F6a CL2
5	Junta	ASTM A182 F304
6	Tornillo	ASTM A193 B7
7	Tuerca	ASTM A194 2H
8	Tapa	ASTM A216 WCB
9	Cierre trasero	ASTM A276 410
10	Empaquetadura	Grafito
11	Pasador	ASTM A29 1035
12	Tornillo de ojo	ASTM A193 B7
13	Tuerca	ASTM A194 2H
14	Prensaestopas	ASTM A276 410
15	Brida prensaestopas	ASTM A216 WCB
16	Tuerca husillo	ASTM A439 D-2
17	Tuerca retén	ASTM A29 1035
18	Volante	ASTM A536 60-40-18
19	Tuerca volante	ASTM A29 1035
20	Engrasador	ASTM A36
21	Pasador partido	ASTM A36
22	Chapa identificación	ASTM A240 321
23	Remache	ASTM A276 321
24	Empaquetadura	Grafito/Acero inox.
25	Linterna	ASTM A276 410
26	Lengüetas	ASTM A105

FIG. GA06013XU - COMPUERTA WCB/F6 XU TRIM N° 8 - 600LBS BW

Código	DN	d	A	SCH 40		SCH 80		SCH 120		L	W	H(S)	H(O)	Peso (kg)
				B	S	B	S	B	S					
-	2"	51	62	52.5	6	49	9			292	250	374	436	32.6
-	2.1/2"	64	75	62.5	8	59	11			330	250	422	497	41.1
-	3"	76	91	78	9	73.5	12			356	300	458	546	54.1
-	4"	102	117	102	10	97	13	92	17	432	350	574	689	94.6
-	5"	127	144	128	10	122	15	116	20	508	450	645	786	145.6

COMPUERTA 600LBS 6" - 12" BRIDAS

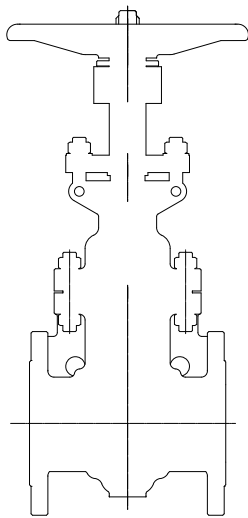

COMPUERTA Fig. GA06011XU		Clase: 600LBS
VÁLVULA COMPUERTA ACERO CARBONO 600LBS BRIDAS		
Especificaciones		
Material	Acero carbono ASTM A216 WCB ¹	
Diseño	API 600	
Conexiones	Bridas según ASME B16.5 RF	
Longitud	ASME B16.10	
Inspección y Pruebas	API 598	
NACE MR 01-75	Bajo demanda	
Aplicaciones	Refinerías, Petroquímica, Química, Metalurgia, Papel, Farmacéuticas...	
¹ Ver lista de materiales estándar		

Componentes		
Pos.	Denominación	Material
1	Cuerpo	ASTM A216 WCB
2	Asientos	ASTM A105 +Stellite
3	Cuña	ASTM A216 WCB +ER410
4	Husillo	ASTM A182 F6a
5	Junta	Ac. inox / Grafito
6	Espárrago	ASTM A193 B7
7	Tuerca	ASTM A194 2H
8	Tapa	ASTM A216 WCB
9	Cierre trasero	ASTM A276 410
10	Empaquetadura	Grafito
11	Pasador	ASTM A29 1035
12	Tornillo de ojo	ASTM A193 B7
13	Tuerca	ASTM A194 2H
14	Prensaestopas	ASTM A276 410
15	Brida prensaestopas	ASTM A216 WCB
16	Puente	ASTM A216 WCB
17	Tuerca husillo	ASTM A439 D-2
18	Casquillo	
19	Tuerca retén	ASTM A29 1035
20	Volante	ASTM A536 60-40-18
21	Tuerca volante	ASTM A29 1035
22	Lubricador	ASTM A36
23	Tuerca	ASTM A194 2H
24	Espárrago	ASTM A193 B7
25	Pasador	ASTM A36
26	Placa identificación	ASTM A240 321
27	Remache	ASTM A276 321
28	Empaquetadura	Ac. inox / Grafito
29	Linterna	ASTM A276 410

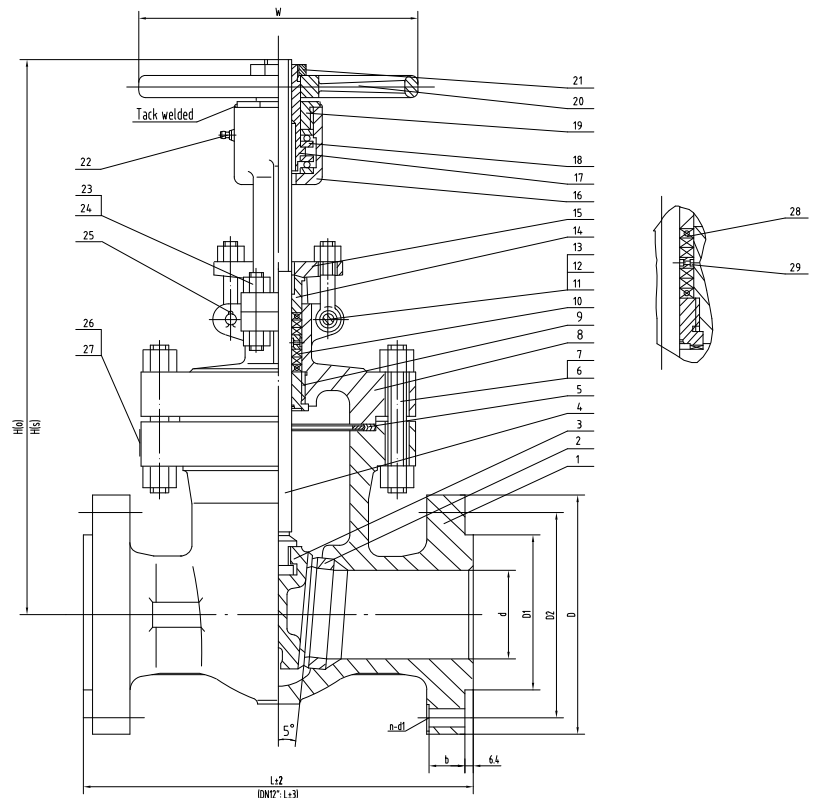
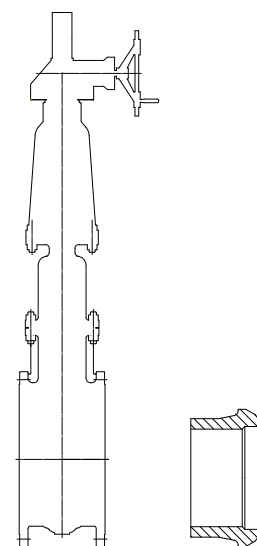

FIG. GA06011XU - COMPUERTA WCB/F6 XU TRIM N° 8 - 600LBS RF

Código	DN	d	D1	D2	D	b	n-d1	L	W	H(s)	H(o)	Peso (kg)
010101302721592	6"	152	216	292	356	48	12-29	559	500	731	900	254.4
010101302721601	8"	200	270	349	419	56	12-32	660	560	820	1037	399.9
-	10"	245	324	432	508	64	16-35	787	720	983	1251	637.7
-	12"	298	381	489	559	67	20-35	838	800			

VÁLVULAS FUNDIDAS ANSI

COMPUERTA 600LBS 6" - 12" BW



COMPUERTA Fig. GA06013XU		Clase: 600LBS
VÁLVULA COMPUERTA ACERO CARBONO 600LBS BW		
Especificaciones		
Material	Acero carbono ASTM A216 WCB ¹	
Diseño	API 600	
Conexiones	Butt Weld según ASME B16.25	
Longitud	ASME B16.10	
Inspección y Pruebas	API 598	
NACE MR 01-75	Bajo demanda	
Aplicaciones	Refinerías, Petroquímica, Química, Metalurgia, Papel, Farmacéuticas...	
¹ Ver lista de materiales estándar		

Componentes		
Pos.	Denominación	Material
1	Cuerpo	ASTM A216 WCB
2	Asientos	ASTM A105 +Stellite 6
3	Cuña	ASTM A216 WCB +Stellite 6
4	Husillo	ASTM A182 F6a CL2
5	Junta	ASTM A182 F304
6	Tornillo	ASTM A193 B7
7	Tuerca	ASTM A194 2H
8	Tapa	ASTM A216 WCB
9	Cierre trasero	ASTM A276 410
10	Empaquetadura	Grafito
11	Pasador	ASTM A29 1035
12	Tornillo de ojo	ASTM A193 B7
13	Tuerca	ASTM A194 2H
14	Prensaestopas	ASTM A276 410
15	Brida prensaestopas	ASTM A216 WCB
16	Puente	ASTM A216 WCB
17	Tuerca husillo	ASTM A439 D-2
18	Cojinete	
19	Tuerca retén	ASTM A29 1035
20	Volante	ASTM A536 60-40-18
21	Tuerca volante	ASTM A29 1035
22	Engrasador	ASTM A36
23	Tornillo	ASTM A193 B7
24	Tuerca	ASTM A194 2H
25	Pasador partido	ASTM A36
26	Chapa identificación	ASTM A240 321
27	Remache	ASTM A276 321
28	Empaquetadura	Grafito / Acero inox.
29	Linterna	ASTM A276 410
30	Lengüetas	ASTM A105

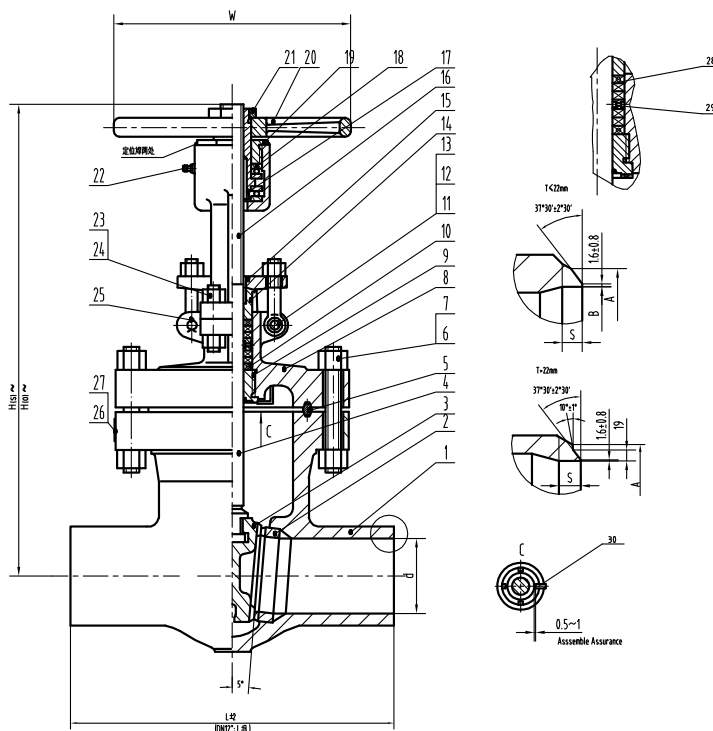
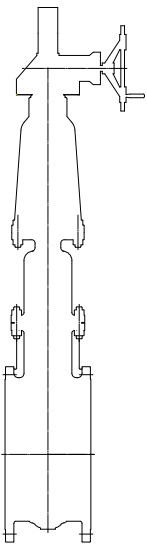

FIG. GA06013XU - COMPUERTA WCB/F6 XU TRIM N° 8 - 600LBS BW

DN	d	A	SCH 40		SCH 60		SCH 80		SCH 100		SCH 120		SCH STD		SCH XS		L	W	H(S)	H(O)	Peso (kg)
			B	S	B	S	B	S	B	S	B	S	B	S	B	S					
6"	152	172	154	11			146.5	17			140	22					559	500	731	900	202.7
8"	200	223	203	13	198.5	16	193.5	20	189	23	182.5	20					660	560	820	1037	323.6
10"	248	278	254.5	14	247.5	20	243	23	236.5	28	230	33					787	720	983	1251	512.9
12"	298	329	303	16	295	22	289	27	281	33	273	39	305	15	298.5	20	838	800	1149	1466	706.8

COMPUERTA 600LBS 8" - 24" BRIDAS CON REDUCTOR



COMPUERTA		Clase: 600LBS
VÁLVULA COMPUERTA ACERO CARBONO 600LBS BRIDAS		
Especificaciones		
Material	Acero carbono ASTM A216 WCB ¹	
Diseño	API 600	
Conexiones	Bridas según ASME B16.47-A RF	
Longitud	ASME B16.10	
Inspección y Pruebas	API 598	
NACE MR 01-75	Bajo demanda	
Aplicaciones	Refinerías, Petroquímica, Química, Metalurgia, Papel, Farmacéuticas...	
¹ Ver lista de materiales estándar		

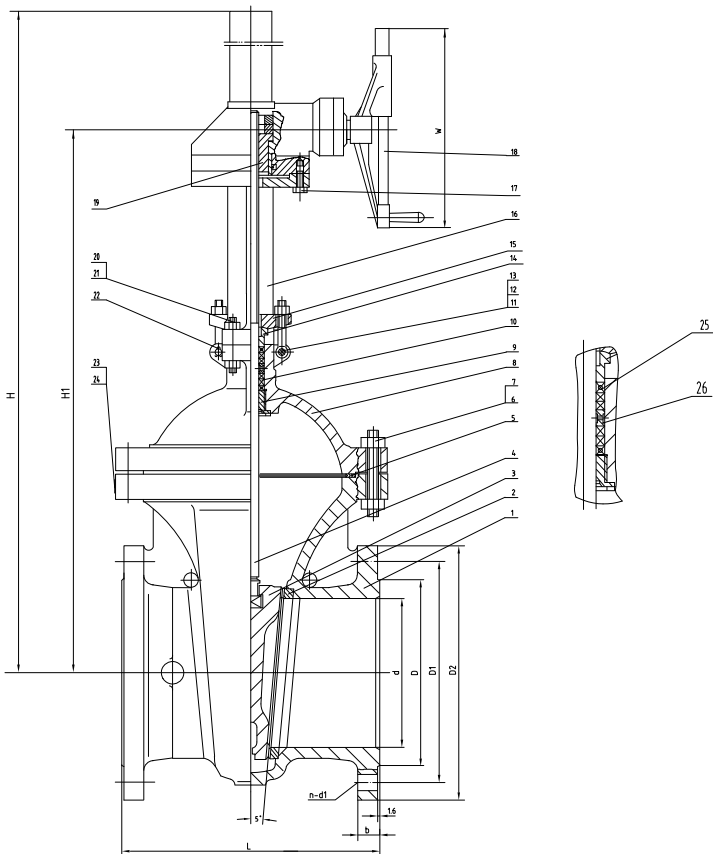

Componentes		
Pos.	Denominación	Material
1	Cuerpo	ASTM A216 WCB
2	Asientos	ASTM A105 +Stellite
3	Cuña	ASTM A216 WCB +ER410
4	Husillo	ASTM A182 F6a
5	Junta	Espirometálica Grafito/SS
6	Tornillo	ASTM A193 B7
7	Tuerca	ASTM A194 2H
8	Tapa	ASTM A216 WCB
9	Cierre trasero	ASTM A276 410
10	Empaquetadura	Grafito
11	Pasador	ASTM A29 1035
12	Tornillo de ojo	ASTM A193 B7
13	Tuerca	ASTM A194 2H
14	Prensaestopas	ASTM A276 410
15	Brida prensaestopas	ASTM A216 WCB
16	Puente	ASTM A216 WCB
17	Tornillo	ASTM A193 B7
18	Reductor manual	
19	Tuerca husillo	ASTM A439 D-2
20	Tuerca	ASTM A194 2H
21	Tornillo	ASTM A193 B7
22	Pasador	ASTM A36
23	Placa identificación	ASTM A240 321
24	Remache	ASTM A276 321
25	Empaquetadura	Grafito/Acero inox.
26	Linterna	ASTM A276 410

FIG. GA06011XU - COMPUERTA WCB/F6 XU TRIM N° 8 - 600LBS RF

Código	DN	d	D1	D2	D	b	n-d1	L	W	H1	H	Peso (kg)
010101302722673	8"	200	270	349	419	56	12-32	660	310			
010101302721479	10"	248	324	432	508	64	16-35	787	460			
010101302723649	12"	298	381	489	559	67	20-35	838	610	1120	1470	851.2
-	14"	327	413	527	603	70	20-38	889	610	1230	1620	1089
-	16"	375	470	603	686	77	20-41	991	610	1389	1825	1487
-	18"	419	533	654	743	83	20-44	1092	610	1505	1990	1874
-	20"	464	584	724	813	89	24-44	1194	610	1582	2167	2671
-	24"	559	692	838	940	102	24-51	1397	760	1863	2548	3828

VÁLVULAS FUNDIDAS ANSI

COMPUERTA 600LBS 8" - 24" BW CON REDUCTOR

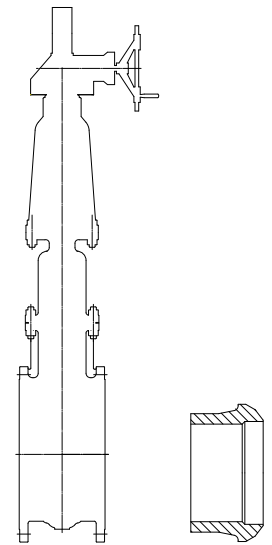

COMPUERTA Fig. GA06013XU		Clase: 600LBS
VÁLVULA COMPUERTA ACERO CARBONO 600LBS BW		
Especificaciones		
Material	Acero carbono ASTM A216 WCB ¹	
Diseño	API 600	
Conexiones	Butt Weld según ASME B16.25	
Longitud	ASME B16.10	
Inspección y Pruebas	API 598	
NACE MR 01-75	Bajo demanda	
Aplicaciones	Refinerías, Petroquímica, Química, Metalurgia, Papel, Farmacéuticas...	
¹ Ver lista de materiales estándar		

Componentes		
Pos.	Denominación	Material
1	Cuerpo	ASTM A216 WCB
2	Asientos	ASTM A105 +Stellite 6
3	Cuña	ASTM A216 WCB +Stellite 6
4	Husillo	ASTM A182 F6a CL2
5	Junta	ASTM A182 F304
6	Tornillo	ASTM A193 B7
7	Tuerca	ASTM A194 2H
8	Tapa	ASTM A216 WCB
9	Cierre trasero	ASTM A276 410
10	Empaquetadura	Grafito
11	Pasador	ASTM A29 1035
12	Tornillo de ojo	ASTM A193 B7
13	Tuerca	ASTM A194 2H
14	Prensaestopas	ASTM A276 410
15	Brida prensaestopas	ASTM A216 WCB
16	Puente	ASTM A216 WCB
17	Tornillo	ASTM A193 B7
18	Reductor manual	
19	Tuerca husillo	
20	Tornillo	ASTM A193 B7
21	Tuerca	ASTM A194 2H
22	Pasador partido	Q235-A
23	Chapa identificación	06Cr18NiTi
24	Remache	06Cr18NiTi
25	Empaquetadura	Grafito / Acero inox.
26	Linterna	ASTM A276 410
27	Lengüetas	ASTM A105

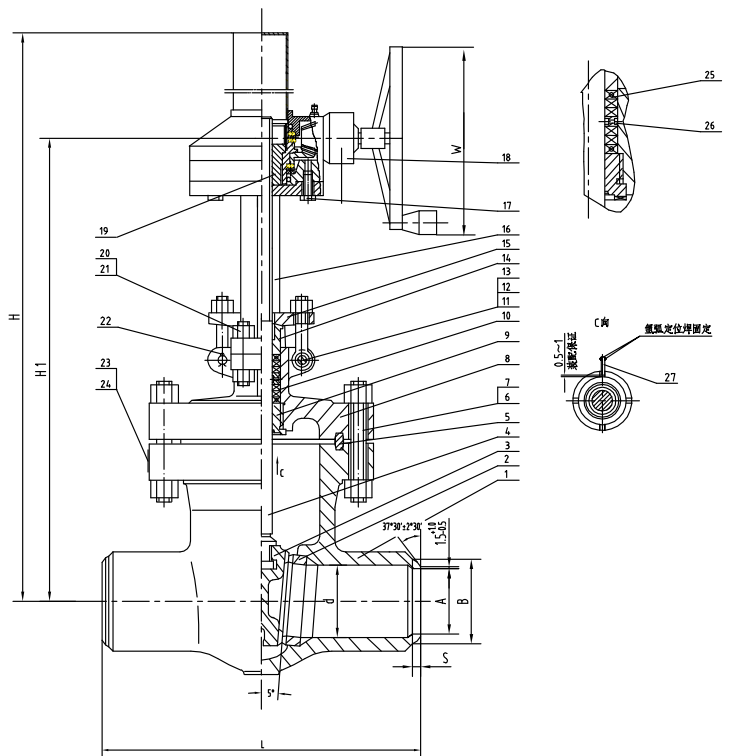
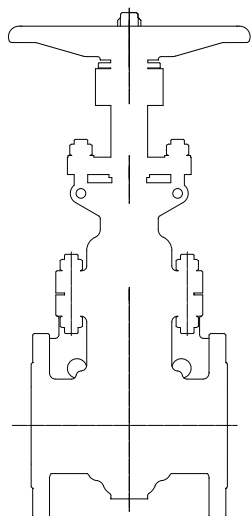

FIG. GA06013XU - COMPUERTA WCB/F6 XU TRIM N° 8 - 600LBS BW

DN	d	A	SCH 40		SCH 80		SCH 120		SCH XS		W	L	H1	H	Peso (kg)
			B	T	B	T	B	T	B	T					
8"	200	223	203	13	193.5	20	182.5	28			310	660	830	1076	332.6
10"	248	278	254.5	14	243	23	230	33			460	787	982	1292	623.9
12"	298	329	303	16	289	27	273	39			610	838	1120	1470	667.7
14"	327	362	333.5	17	317.5	29	300	42			610	889	1230	1620	1152.8
16"	375	413	381	20	363.5	33	344.5	47			610	991	1389	1825	1421.2
18"	419	464	428.5	22	409.5	36	387.5	53			610	1092	1505	1990	1463.4
20"	464	516	478	23	455.5	40	432	58			610	1194	1582	2167	2171
24"	559	619	574.5	27	547.5	47	476	62			760	1397	1863	2548	3428

COMPUERTA 600LBS 26" - 36" BRIDAS CON REDUCTOR



COMPUERTA		Clase: 600LBS
VÁLVULA COMPUERTA ACERO CARBONO 600LBS BRIDAS		
Especificaciones		
Material	Acero carbono ASTM A216 WCB ¹	
Diseño	API 600	
Conexiones	Bridas según ASME B16.47-A RF	
Longitud	ASME B16.10	
Inspección y Pruebas	API 598	
NACE MR 01-75	Bajo demanda	
Aplicaciones	Refinerías, Petroquímica, Química, Metalurgia, Papel, Farmacéuticas...	
¹ Ver lista de materiales estándar		

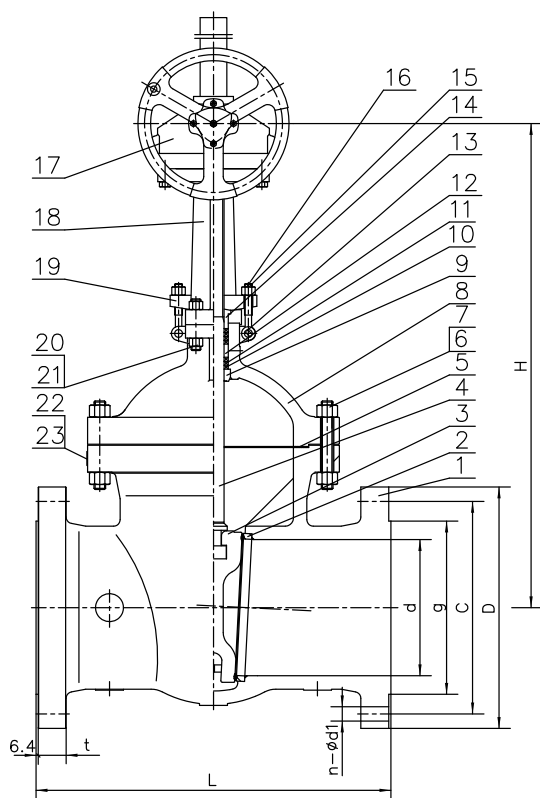

Componentes			
Pos.	Denominación	Cant.	Material
1	Cuerpo	1	ASTM A216 WCB
2	Asientos	2	ASTM A105 +Stellite
3	Cuña	1	ASTM A216 WCB +13Cr
4	Husillo	1	ASTM A182 F6a
5	Junta	1	Spirom. 304 / Grafito
6	Tornillo	1	ASTM A194 B7
7	Tuerca	1	ASTM A194 2H
8	Tapa	1	ASTM A216 WCB
9	Back seat	1	ASTM A276 304
10	Empaquetadura	2	Grafito
11	Empaquetadura	5-7	Grafito flexible
12	Linterna	1	ASTM A276 410
13	Pasador	2	ASTM A108 1035
14	Casquillo prensa	1	ASTM A276 410
15	Tornillo de ojo	2	ASTM A193 B7
16	Tuerca	2	ASTM A194 2H
17	Reductor	1	
18	Puente	1	ASTM A216 WCB
19	Brida prensaestopas	1	ASTM A216 WCB
20	Tornillo	4	ASTM A193 B7
21	Tuerca	8	ASTM A194 2H
22	Placa identificación	1	304SS
23	Remache	2	304SS

COMPUERTA WCB/F6 XU TRIM N° 8 - 600LBS RF

Código	DN	d	L	D	C	g	t	n	d1	H	Peso (kg)
-	26"	603	1.448	1.015	914,4	749	108	28	51	2.115	5.220
-	28"	648	1.549,4	1.073,2	965,2	800,1	111,2	28	54	2.300	5.823
-	30"	695	1.651	1.130	1.022,4	857	115	28	54	2.506	7.258
-	32"	781	1.778	1.195	1.079,5	914	118	28	61	2.786	9.565
-	36"	876	2.083	1.315	1.194	1.022	124	28	67	2.952	11.084

VÁLVULAS FUNDIDAS ANSI

COMPUERTA 900LBS 2" - 6" BRIDAS

COMPUERTA Fig. GA09012XU		Clase: 900LBS
VÁLVULA COMPUERTA ACERO CARBONO 900LBS BRIDAS		
Especificaciones		
Material	Acero carbono ASTM A216 WCB ¹	
Diseño	API 600	
Conexiones	Bridas según ASME B16.5 RF	
Longitud	ASME B16.10	
Inspección y Pruebas	API 598	
NACE MR 01-75	Bajo demanda	
Aplicaciones	Refinerías, Petroquímica, Química, Metalurgia, Papel, Farmacéuticas...	
¹ Ver lista de materiales estándar		

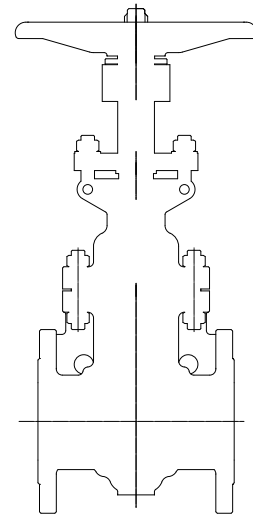

Componentes		
Pos.	Denominación	Material
1	Cuerpo	ASTM A216 WCB
2	Asientos	ASTM A105 +Stellite
3	Cuña	ASTM A216 WCB +ER410
4	Husillo	ASTM A182 F6a CL2
5	Junta	RTJ o Espirom. Grafito/Ac.inox.
6	Tornillo	ASTM A193 B7
7	Tuerca	ASTM A194 2H
8	Tapa	ASTM A216 WCB
9	Cierre trasero	ASTM A276 410
10	Empaquetadura	Grafito
11	Pasador	Acero carbono
12	Tornillo	ASTM A193 B7
13	Tuerca	ASTM A194 2H
14	Prensaestopas	ASTM A276 410
15	Brida prensaestopas	Acero carbono
16	Tuerca husillo	ASTM A439 D-2
17	Tuerca retén	Acero carbono
18	Volante	Hierro Fundido
19	Tuerca volante	Acero carbono
20	Engrasador	Acero carbono
21	Pasador	Acero carbono
22	Placa identificación	Acero carbono
23	Remache	Acero inoxidable
24	Empaquetadura	Grafito + Acero inox.
25	Linterna	ASTM A276 410
26	Casquillo	

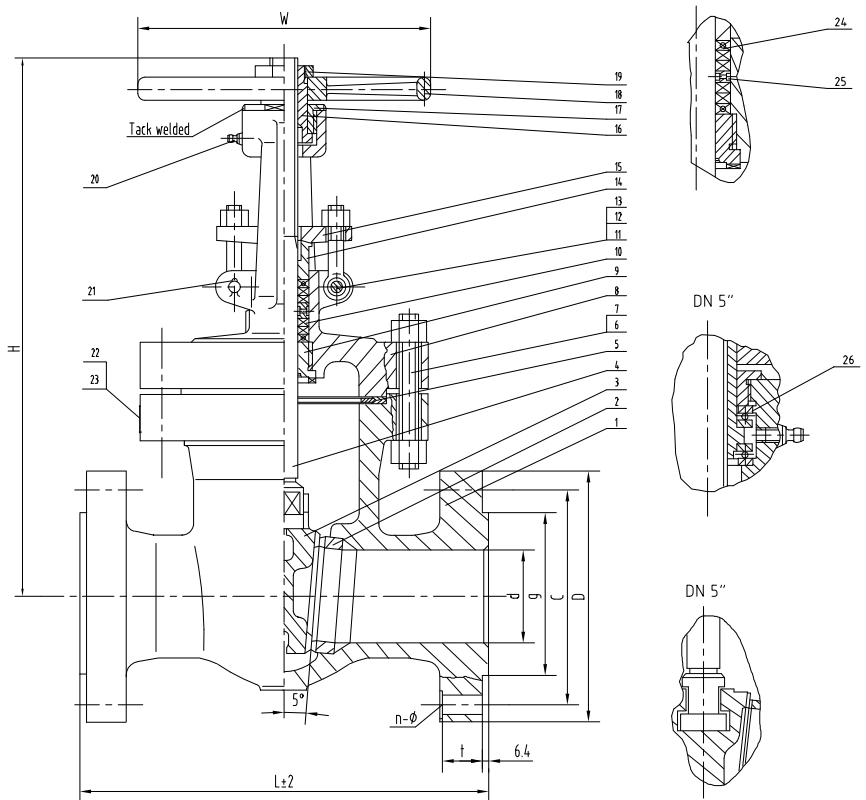
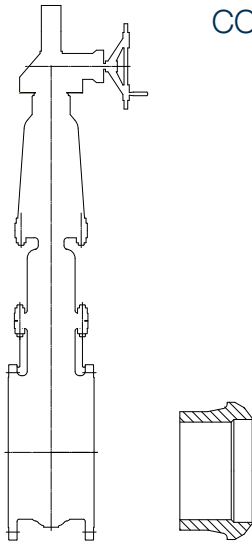

FIG. GA09012XU - COMPUERTA WCB/F6 XU TRIM N° 8 - 900LBS RF

Código	DN	d	g	C	D	t	n-∅	L	W	H		Peso (kg)
										cerrada	abierta	
-	2"	51	92	127	165	26	8-∅19	292	250	374	436	39.3
-	2.1/2"	64	105	149	190	290	8-∅22	330	250	422	497	50.9
010101302722775	3"	76	127	168	210	32	8-∅22	356	300	458	546	67.5
010101302722774	4"	102	157	216	273	38.1	8-∅25	432	350	574	689	121.2
-	5"	127	186	266.5	330	45	8-∅29	508	450	645	786	191
-	6"	152	216	292	356	48	12-∅29	559	500	731	900	254.4

COMPUERTA 900LBS 8" - 24" DISEÑO PRESSURE SEAL CON REDUCTOR



COMPUERTA Fig. GA09013XU		Clase: 900LBS
VÁLVULA COMPUERTA ACERO CARBONO 900LBS SOLDAR		
Especificaciones		
Material	Acero carbono ASTM A216 WCB ¹	
Diseño	API 600	
Conexiones	Butt Welding según ASME B16.25	
Longitud	ASME B16.10	
Inspección y Pruebas	API 598	
NACE MR 01-75	Bajo demanda	
Aplicaciones	Refinerías, Petroquímica, Química, Metalurgia, Papel, Farmacéuticas...	
¹ Ver lista de materiales estándar		

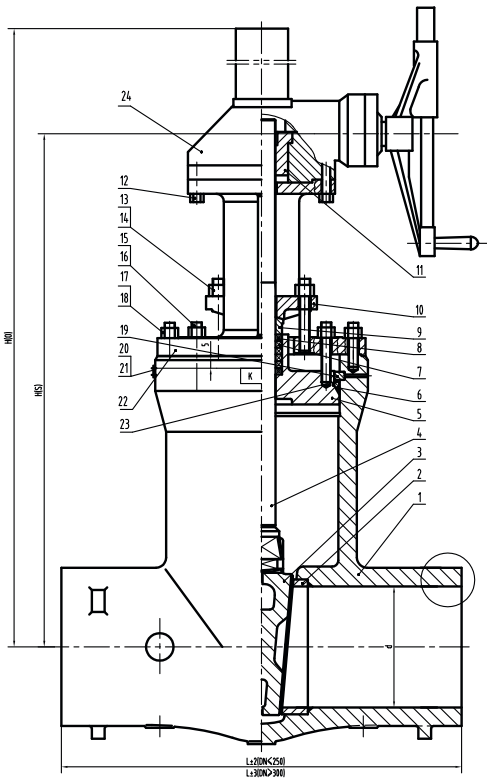

管子壁厚小于22mm焊接端口

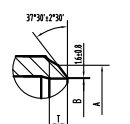

管子壁厚大于22mm焊接端口

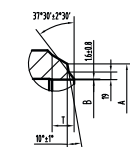

Componentes		
Pos.	Denominación	Material
1	Cuerpo	ASTM A216 WCB
2	Asientos	ASTM A105 +Stellite 6
3	Cuña	ASTM A216 WCB +Stellite 6
4	Husillo	ASTM A182 F6a CL2
5	Caja prensaestopas	ASTM A105
6	Anillo sellado	ASTM A182 F304
7	Empaquetadura	Grafito flexible
8	Empaquetadura	Ac. inox / Grafito
9	Prensaestopas	ASTM A276 410
10	Brida prensaestopas	ASTM A216 WCB
11	Tuerca husillo	ASTM A439 D-2
12	Tornillo	ASTM A29 1035
13	Espárrago	ASTM A193 B7
14	Tuerca	ASTM A194 2H
15	Espárrago	ASTM A193 B7
16	Tuerca	ASTM A194 2H
17	Espárrago	ASTM A193 B7
18	Tuerca	ASTM A194 2H
19	Anillo segmentado	ASTM A29 1045
20	Placa identificación	ASTM A240 321
21	Remache	ASTM A276 321
22	Puente	ASTM A216 WCB
23	Arandela	ASTM A36
24	Reductor manual	

FIG. GA09013XU - COMPUERTA WCB/F6 XU TRIM N° 8 - 900LBS BW

Código	DN	d	A	SCH 80		SCH 100		SCH 120		SCH 140		SCH 160		L	H(O)	H(S)	Peso (kg)
				B	s	B	s	B	s	B	s	B	s				
-	8"	190	223	193.5	20	189.0	23	182.5	28	178.0	31	173.0	35	660	1115	860	371
-	10"	238	278	243.0	23	236.5	28	230.0	33	222.0	39	216.0	43	787	1328	1023	578.1
-	12"	282	329	289.0	27	281.0	33	273.0	39	266.5	43	257.0	50	914	1518	1194	908.4
-	14"	311	362	317.5	29	308.0	36	300.0	42	292.0	48	284.0	54	991	1659	1295	1147.8
-	16"	356	413	363.5	33	354.0	40	344.5	47	333.5	55	325.5	61	1092	1839	1441	1774.8
-	18"	400	464	409.5	36	398.5	44	387.5	53	378.0	60	367.0	68	1219	2265	1660	3532.2
-	20"	444	516	455.5	40	443.0	49	432.0	58	419.0	67	408.0	75	1321	2355	1806	4898.5
-	24"	533	619	548.0	47	532.0	59	517.5	69	505.0	79	490.5	90	1549	2835	2224	6677.0

VÁLVULAS FUNDIDAS ANSI

COMPUERTA 900LBS 26" - 30" CON REDUCTOR

COMPUERTA		Clase: 900LBS
VÁLVULA COMPUERTA ACERO CARBONO 900LBS SOLDAR		
Especificaciones		
Material	Acero carbono ASTM A216 WCB ¹	
Diseño	API 600	
Conexiones	SW según ANSI B16.10 y Butt Welding según ANSI B16.25	
Longitud	ASME B16.10	
Inspección y Pruebas	API 598	
NACE MR 01-75	Bajo demanda	
Aplicaciones	Refinerías, Petroquímica, Química, Metalurgia, Papel, Farmacéuticas...	
¹ Ver lista de materiales estándar		

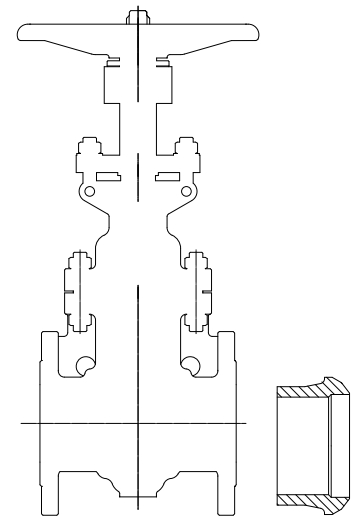

Componentes		
Pos.	Denominación	Material
1	Cuerpo	ASTM A216 WCB +13% Cr
2	Asientos	ASTM A105 +Stellite 6
3	Cuña	ASTM A216 WCB +13% Cr
4	Husillo	ASTM A182 F6a
5	Tapa	A105 +13% Cr
6	Anillo asiento	A182 F304L
7	Empaquetadura	Grafito flexible
8	Empaquetadura	Grafito trenzado
9	Prensaestopas	A276 410
10	Brida prensaestopas	A216 WCB
11	Tuerca husillo	A439 D-2
12	Reductor manual	
13	Tornillo	ANSI 1035
14	Tuerca	A194 2H
15	Tornillo ojo	A193 B7
16	Tuerca	A194 2H
17	Tornillo	A193 B7
18	Tuerca	A194 2H
19	Tornillo	A193 B7
20	Anillo empuje partido	ANSI 1045
21	Puente	A216 WCB
22	Remache	AISI 304
23	Placa identificación	AISI 304
24	Anillo espaciador	ANSI 1045

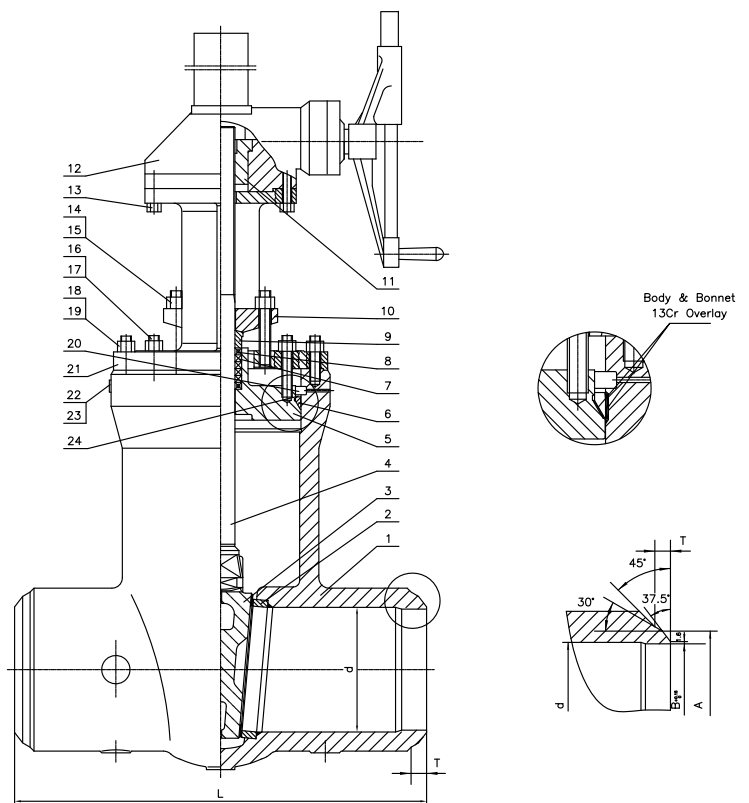

COMPUERTA WCB/F6 XU TRIM N° 8 - 900LBS BW

Código	DN	SCH	d	L	A	B	t
-	26"	20	578	1654	670	635	25
-	28"	20	622	1752	721	686	30
-	30"	20	667	1854	772	737	35

COMPUERTA 1500LBS 2" - 4" DISEÑO PRESSURE SEAL

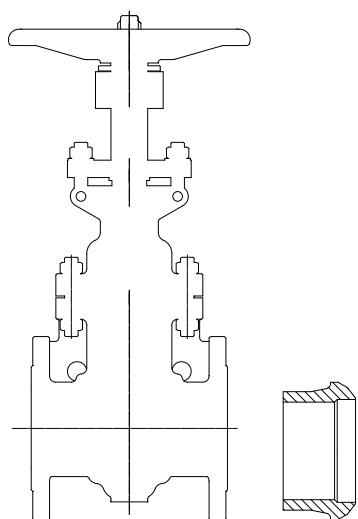

COMPUERTA Fig. GA150013XU		Clase: 1500LBS
VÁLVULA COMPUERTA ACERO CARBONO 1500LBS SOLDAR		
Especificaciones		
Material	Acero carbono ASTM A216 WCB ¹	
Diseño	API 600	
Conexiones	Butt Welding según ASME B16.25	
Longitud	ASME B16.10	
Inspección y Pruebas	API 598	
NACE MR 01-75	Bajo demanda	
Aplicaciones	Refinerías, Petroquímica, Química, Metalurgia, Papel, Farmacéuticas...	
¹ Ver lista de materiales estándar		

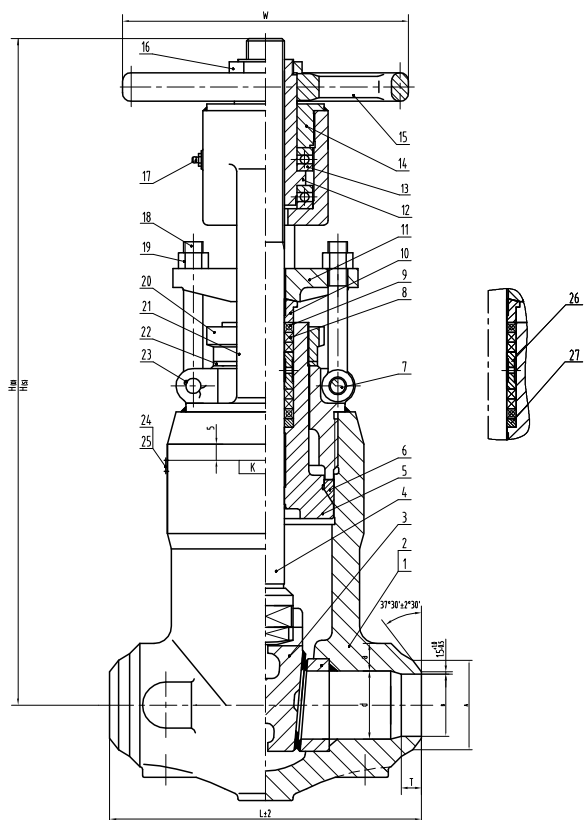

Componentes		
Pos.	Denominación	Material
1	Cuerpo	ASTM A216 WCB
2	Asientos	ASTM A105 +Stellite
3	Cuña	ASTM A216 WCB
4	Husillo	ASTM A182 F6a CL2
5	Caja prensaestopas	ASTM A105
6	Anillo sellado	ASTM A182 F304
7	Pasador	ASTM A29 1035
8	Empaquetadura	Grafito
9	Empaquetadura	Ac. inox / Grafito
10	Prensaestopas	ASTM A276 410
11	Brida prensaestopas	ASTM A216 WCB
12	Tuerca husillo	ASTM A439 D-2
13	Casquillo	
14	Tuerca	ASTM 29 1035
15	Handwheel	ASTM A216 WCB
16	Tuerca	ASTM A29 1035
17	Lubricador	ASTM A36
18	Tornillo	ASTM A193 B7
19	Tuerca	ASTM A194 2H
20	Tuerca	ASTM A29 1045
21	Puente	ASTM A216 WEB
22	Arandela	ASTM A36
23	Pasador	ASTM A36
24	Placa identificación	ASTM A240 321
25	Remache	ASTM A276 321
26	Linterna	ASTM A276 321
27	Arandela prensaestopas	ASTM A276 321

FIG. GA15013XU - COMPUERTA WCB/F6 XU TRIM N° 8 - 1500LBS BW

Código	DN	a	d	A	SCH 80		SCH 120		SCH 160		SCH XXS		L	W	H2	H1	Peso (kg)
					B	T	B	T	B	T	B	T					
-	2"	19.1	47	62	49	9			43	14	38	17	216	300	501	560	39.5
-	3"	23.9	70	91	73.5	12			66.5	17	58.5	23	305	350	622	705	77.6
-	4"	28.7	92	117	97	13	92	17	87.5	21	80	26	406	450	704	810	135.1

VÁLVULAS FUNDIDAS ANSI

COMPUERTA 1500LBS 6" - 24" DISEÑO PRESSURE SEAL CON REDUCTOR

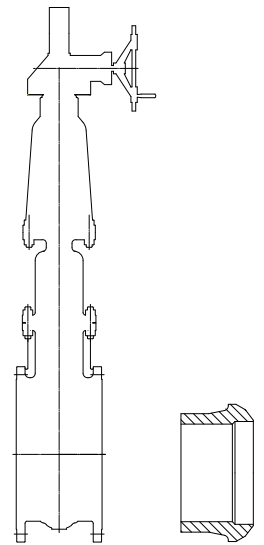

COMPUERTA		Clase: 1500LBS
VÁLVULA COMPUERTA ACERO CARBONO 1500LBS SOLDAR		
Especificaciones		
Material	Acero carbono ASTM A216 WCB ¹	
Diseño	API 600	
Conexiones	Butt Welding según ASME B16.25	
Longitud	ASME B16.10	
Inspección y Pruebas	API 598	
NACE MR 01-75	Bajo demanda	
Aplicaciones	Refinerías, Petroquímica, Química, Metalurgia, Papel, Farmacéuticas...	
¹ Ver lista de materiales estándar		

Componentes		
Pos.	Denominación	Material
1	Cuerpo	ASTM A216 WCB +13% Cr
2	Asientos	ASTM A105 +Stellite 6
3	Cuña	ASTM A216 WCB +13% Cr
4	Husillo	ASTM A182 F6a
5	Tapa	A105 +13% Cr
6	Anillo asiento	A182 304L
7	Empaquetadura	Grafito flexible
8	Empaquetadura	Grafito trenzado
9	Prensaestopas	A276 410
10	Brida prensaestopas	A216 WCB
11	Tuerca husillo	A439 D-2
12	Reductor manual	
13	Tornillo	ANSI 1035
14	Tuerca	A194 2H
15	Tornillo ojo	A193 B7
16	Tuerca	A194 2H
17	Tornillo	A193 B7
18	Tuerca	A194 2H
19	Tornillo	A193 B7
20	Anillo empuje partido	ANSI 1045
21	Puente	A216 WCB
22	Remache	AISI 304
23	Placa identificación	AISI 304
24	Anillo espaciador	ANSI 1045

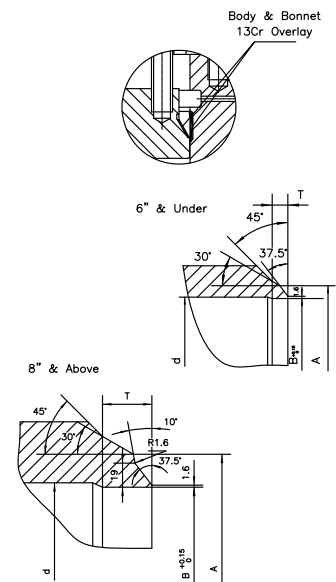
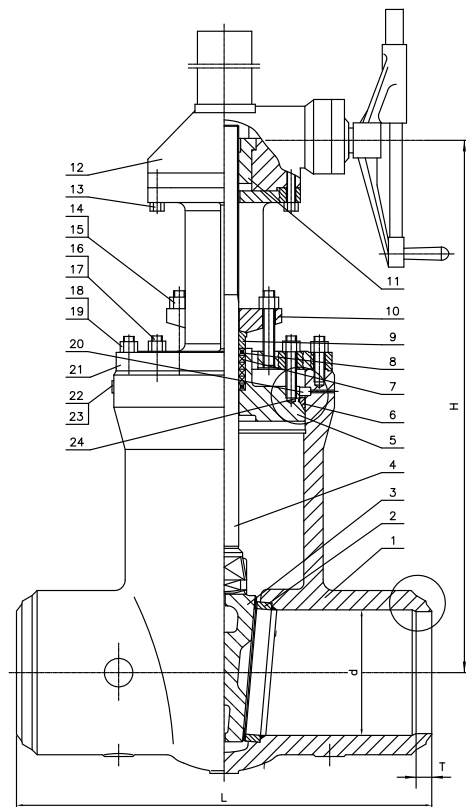

COMPUERTA WCB/F6 XU TRIM N° 8 - 1500LBS BW

Código	DN	SCH	d	L	A	B	t	H
-	6"	160	136	559	172	132	28	737
-	8"	160	178	711	223	173	35	892
-	10"	160	222	864	278	216	45	1175
-	12"	160	263	991	329	257	50	1505
-	14"	160	289	1067	362	284	55	1603
-	16"	160	330	1194	413	325	60	1664
-	18"	160	371	1346	464	367	70	1816
-	20"	160	416	1473	516	408	75	1975
-	24"	160	498	1753	619	491	90	2138

COMPUERTA 2500LBS 2" - 4" DISEÑO PRESSURE SEAL

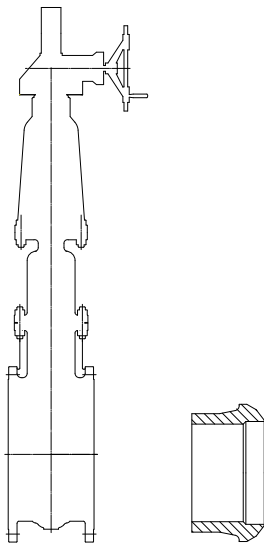

COMPUERTA		Clase: 2500LBS
VÁLVULA COMPUERTA ACERO CARBONO 2500LBS SOLDAR		
Especificaciones		
Material	Acero carbono ASTM A216 WCB ¹	
Diseño	API 600	
Conexiones	Butt Welding según ASME B16.25	
Longitud	ASME B16.10	
Inspección y Pruebas	API 598	
NACE MR 01-75	Bajo demanda	
Aplicaciones	Refinerías, Petroquímica, Química, Metalurgia, Papel, Farmacéuticas...	
¹ Ver lista de materiales estándar		

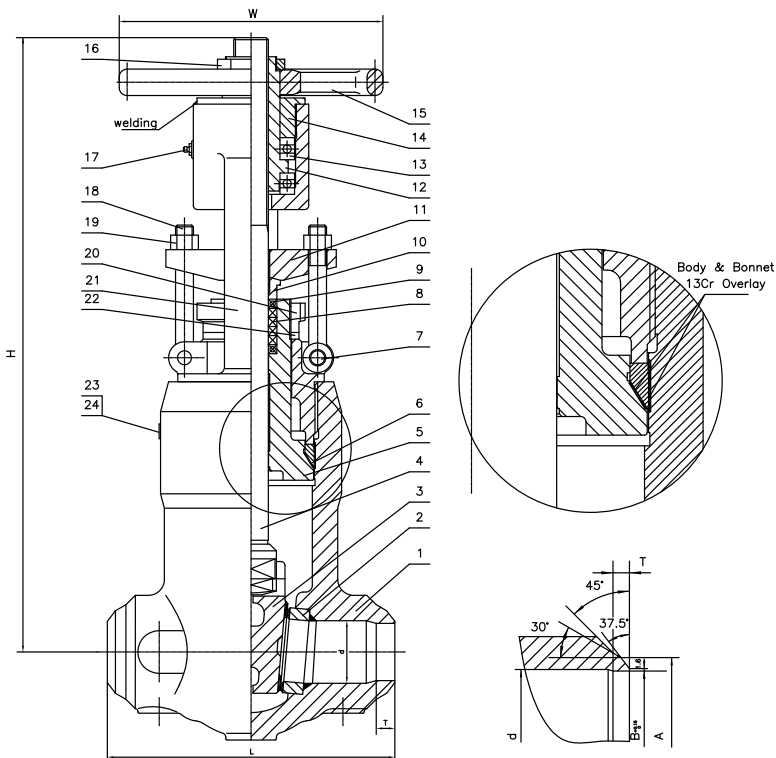

Componentes		
Pos.	Denominación	Material
1	Cuerpo	ASTM A216 WCB +13% Cr
2	Asientos	ASTM A105 +Stellite 6
3	Cuña	ASTM A216 WCB +13% Cr
4	Husillo	ASTM A182 F6a
5	Tapa	A105 +13% Cr
6	Anillo Sellado	A182 F304L
7	Pasador	A105 1035
8	Empaquetadura	Grafito flexible
9	Empaquetadura	Grafito trenzado
10	Prensaestopas	A276 410
11	Brida prensaestopas	A216 WCB
12	Tuerca husillo	A439 D-2
13	Cojinete	UNS 52100
14	Retén	A108 1020
15	Volante	A536 60-40-18
16	Tuerca volante	A108 1020
17	Nipple engrasador	Latón
18	Tornillo ojo	A193 B7
19	Tuerca	A194 2H
20	Tuerca bloqueo	A108 1035
21	Puente	A216 WCB
22	Junta	A105
23	Remache	AISI 304
24	Placa identificación	AISI 304

COMPUERTA WCB/F6 XU TRIM N° 8 - 2500LBS BW

Código	DN	SCH	d	L	A	B	t	H	W
-	2"	160	38	279	62	49	14	585	450
-	3"	160	57	368	91	67	17	756	500
-	4"	160	73	457	117	87	22	854	560

VÁLVULAS FUNDIDAS ANSI

COMPUERTA 2500LBS 6" - 20" DISEÑO PRESSURE SEAL CON REDUCTOR

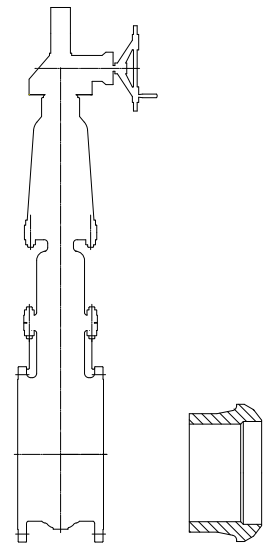

COMPUERTA		Clase: 2500LBS
VÁLVULA COMPUERTA ACERO CARBONO 2500LBS SOLDAR		
Especificaciones		
Material	Acero carbono ASTM A216 WCB ¹	
Diseño	API 600	
Conexiones	Butt Welding según ASME B16.25	
Longitud	ASME B16.10	
Inspección y Pruebas	API 598	
NACE MR 01-75	Bajo demanda	
Aplicaciones	Refinerías, Petroquímica, Química, Metalurgia, Papel, Farmacéuticas...	
¹ Ver lista de materiales estándar		

Componentes		
Pos.	Denominación	Material
1	Cuerpo	ASTM A216 WCB +13% Cr
2	Asientos	ASTM A105 +Stellite 6
3	Cuña	ASTM A216 WCB +13% Cr
4	Husillo	ASTM A182 F6a
5	Tapa	A105 +13% Cr
6	Anillo Sellado	A182 F304L
7	Empaquetadura	Grafito flexible
8	Empaquetadura	Grafito trenzado
9	Prensaestopas	A276 410
10	Brida prensaestopas	A216 WCB
11	Tuerca husillo	A439 D-2
12	Reductor manual	
13	Tornillo	ANSI 1035
14	Tuerca	A194 2H
15	Tornillo ojo	A193 B7
16	Tuerca	A194 2H
17	Tornillo	A193 B7
18	Tuerca	A194 2H
19	Tornillo	A193 B7
20	Anillo empuje partido	ANSI 1045
21	Puente	A216 WCB
22	Remache	AISI 304
23	Placa identificación	AISI 304
24	Anillo espaciador	ANSI 1045

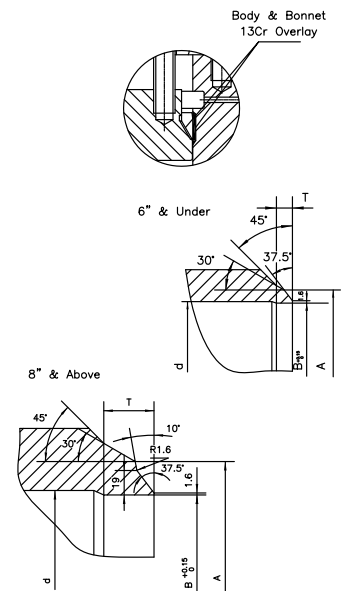
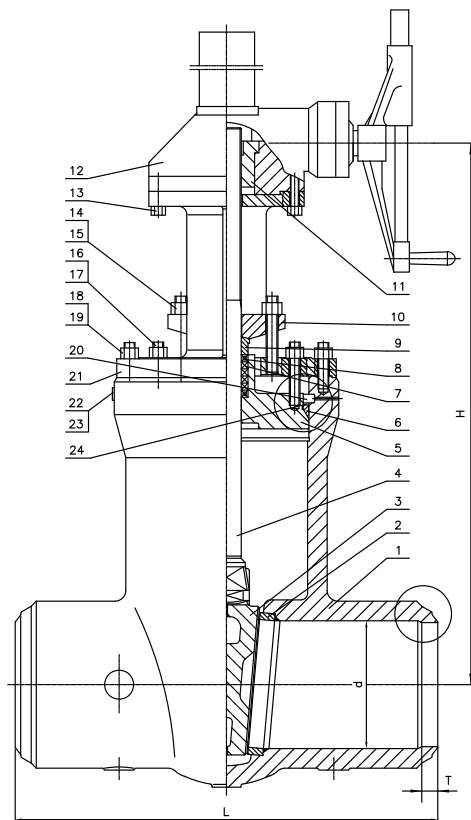

COMPUERTA WCB/F6 XU TRIM N° 8 - 2500LBS BW

Código	DN	SCH	d	L	A	B	t	H
-	6"	160	111	610	172	132	28	788
	8"	160	146	762	223	173	35	942
	10"	160	184	914	278	216	45	1226
	12"	160	219	1041	329	257	50	1556
	14"	160	241	1118	362	284	55	1654
	16"	160	276	1245	413	325	60	1715
	18"	160	311	1397	464	367	70	1867
-	20"	160	343	1524	516	408	75	2036

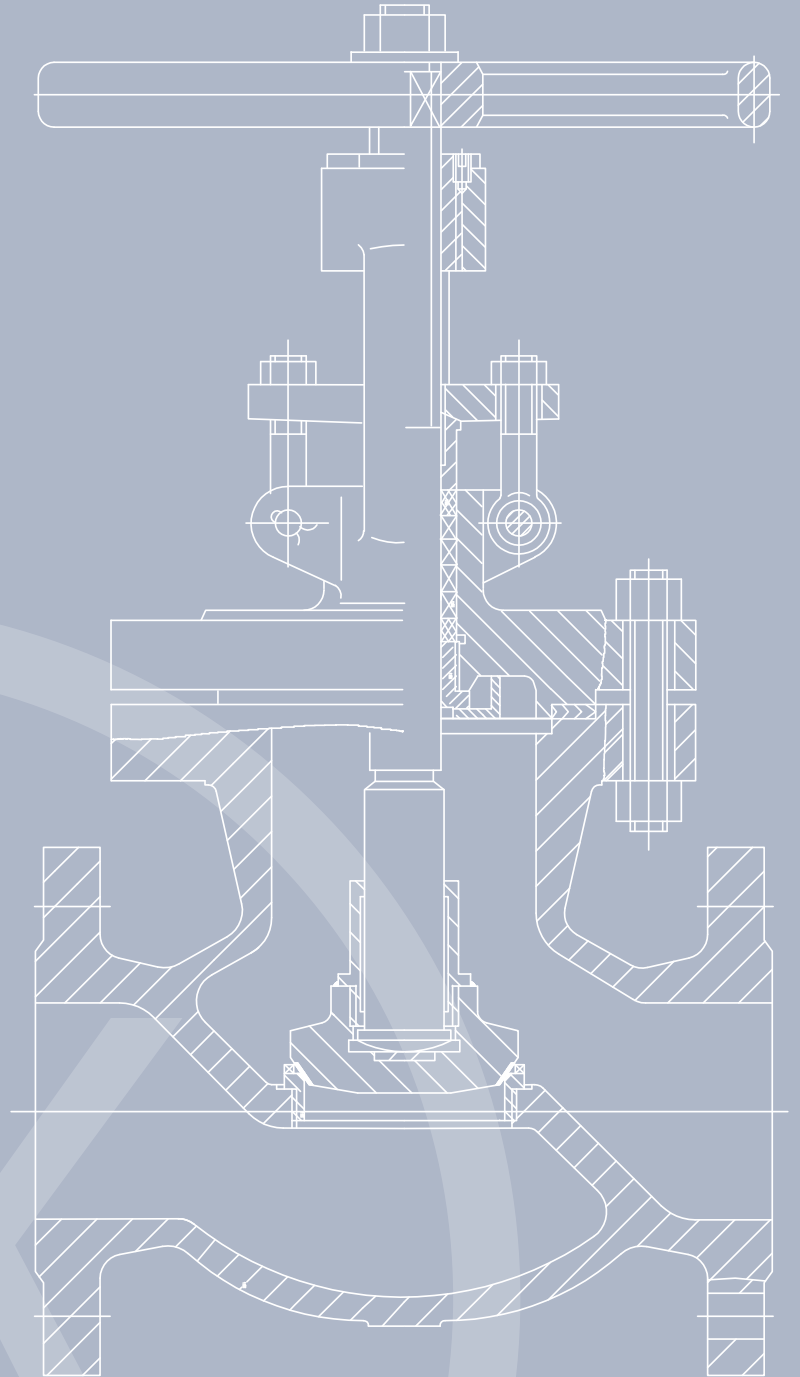

GLOBEVALVES



VÁLVULAS DE GLOBO - LISTA DE MATERIALES DE CONSTRUCCIÓN ESTÁNDAR

PIEZA	ACERO CARBONO		ACERO ALEADO				ACERO INOXIDABLE			
Cuerpo	A216 WCB	A352 LCB	A217 WC1	A217 WC6	A217 WC9	A217 C5	A351 CF8	A351 CF8M	A351 CF3	A351 CF3M
Tapa	A216 WCB	A352 LCB	A217 WC1	A217 WC6	A217 WC9	A217 C5	A351 CF8	A351 CF8M	A351 CF3	A351 CF3M
Tornillos cuerpo-tapa	A193 B7	A320 L7	A193 B7	A193 B16	A193 B16	A193 B16	A193 B8	A193 B8	A193 B8	A193 B8
Tuercas cuerpo-tapa	A194 2H	A194 Gr. 4	A194 2H	A194 Gr. 4	A194 Gr. 4	A194 Gr. 4	A194 Gr. 8	A194 Gr. 8	A194 Gr. 8	A194 Gr. 8
Linterna	410	410	410	410	410	410	304	316	304L	316L
Pasadores	Acero	Acero	Acero	Acero	Acero	Acero	Acero inox	Acero inox	Acero inox	Acero inox
Prensaestopas	A182 F6	A182 F6	A182 F6	A182 F6	A182 F6	A182 F6	304	316	304L	316L
Brida prensa	A105	A350 LF2	A105	A105	A105	A105	304	316	304L	316L
Tornillo prensa	A193 B7	A320 L7	A193 B7	A193 B7	A193 B7	A193 B7	A193 B8	A193 B8	A193 B8	A193 B8
Tuercas	A194 2H	A194 Gr. 4	A194 2H	A194 2H	A194 2H	A194 2H	A194 Gr. 8	A194 Gr. 8	A194 Gr. 8	A194 Gr. 8
Disco (obturador)	A182 F6	A182 F304	A182 F6	A182 F6	A182 F6	A182 F6	A182 F304	A182 F304	A182 F304	A182 F304
Junta cuerpo-tapa	Espirometálica en Acero inox/Grafito o Ac. inox/PTFE o Ac.inox/PTFE reforzado									
Empaquetadura	Anillo de Grafito trenzado o preformado, o PTFE									
Tuerca husillo	A439 D2 o A276 410									
Volante	Hierro Fundido									
Arandela volante	Acero									
Tuerca volante	Acero									
Engrasador	Acero									
Placa identificación	Acero inoxidable o Aluminio									
Anillo de fricción	A182 F6									

Otros materiales (Alloy 20, AISI 321, AISI 347, Monel, Hastelloy, etc.) bajo demanda

MATERIALES DEL TRIM SEGÚN API 600¹

CÓDIGO ASIENTO	SUPERFICIE ASIENTO DEL CUERPO	SUPERFICIE ASIENTO DEL DISCO	HUSILLO	CIERRE TRASERO
X	F6	F6	F6	F6
U	Stellite	Stellite	F6	F6
XU	Stellite	F6	F6	F6
P	F304	F304	F304	F304
R	F316	F316	F316	F316
M	Monel	Monel	Monel	Monel
N	Alloy 20	Alloy 20	Alloy 20	Alloy 20
H	Hastelloy B	Hastelloy B	Hastelloy B	Hastelloy B
B	Bronce	Bronce	Bronce	Bronce

¹ Encontrará más información sobre materiales del trim al final de este catálogo

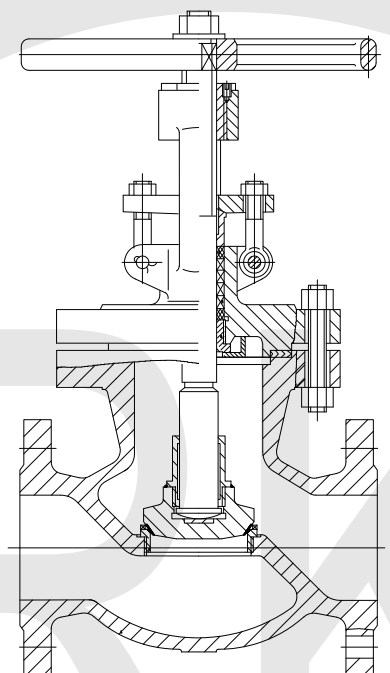

VÁLVULAS FUNDIDAS ANSI

GLOBO 150LBS 2" - 6" BRIDAS

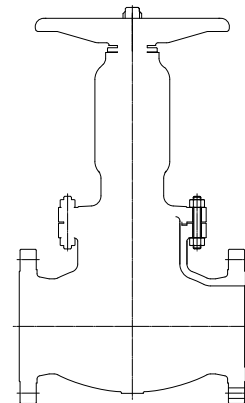

Globo Fig. GL01011XU		Clase: 150LBS
VÁLVULA GLOBO ACERO CARBONO 150LBS BRIDAS		
Especificaciones		
Material	Acero carbono ASTM A216 WCB ¹	
Diseño	BS 1873	
Conexiones	Bridas según ASME B16.5 RF	
Longitud	ASME B16.10	
Inspección y Pruebas	API 598	
NACE MR 01-75	Bajo demanda	
Aplicaciones	Refinerías, Petroquímica, Química, Metalurgia, Papel, Farmacéuticas...	
¹ Ver lista de materiales estándar		

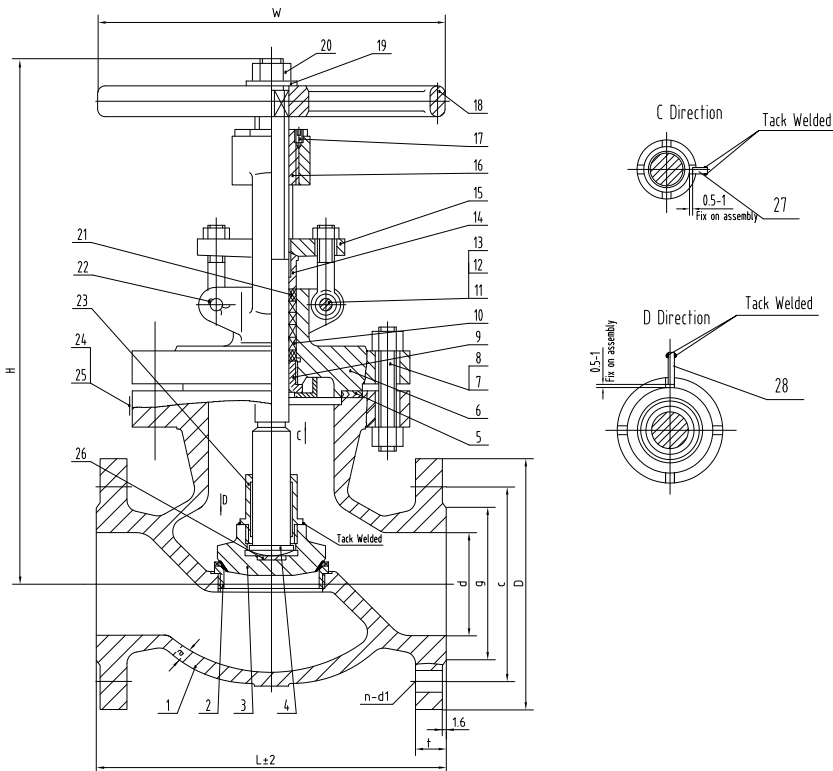

Componentes		
Pos.	Denominación	Material
1	Cuerpo	ASTM A216 WCB
2	Asientos	ASTM A105 +ER410
3	Disco	ASTM A105 +Stellite
4	Husillo	ASTM A182 F6a
5	Junta	Espirometálica Grafito/Ac.inox.
6	Tapa	ASTM A216 WCB
7	Tuerca	ASTM A194 2H
8	Espárrago	ASTM A193 B7
9	Cierre trasero	ASTM A276 410
10	Empaquetadura	Grafito
11	Pasador	ASTM A29 1035
12	Tornillo de ojo	ASTM A193 B7
13	Tuerca	ASTM A194 2H
14	Prensaestopas	ASTM A276 410
15	Brida prensaestopas	ASTM A216 WCB
16	Tuerca husillo	ASTM A439 D-2
17	Tornillo	ASTM A29 1035
18	Volante	ASTM 536 60-40-18
19	Arandela	ASTM A36
20	Tuerca volante	ASTM A36
21	Empaquetadura	Grafito/Acero inox.
22	Pasador	ASTM A36
23	Tapa disco	ASTM A276 410
24	Placa identificación	ASTM A240 321
25	Remache	ASTM A276 321
26	Arandela empuje	ASTM A276 420
27	Lengüeta	ASTM A29 1025
28	Lengüeta	ASTM A29 1025

FIG. GL01011XU - GLOBO WCB/F6 XU TRIM N° 8 - 150LBS RF

Código	DN	d	g	C	D	t	n-d1	L	W	a	H		Peso (kg)
											cerrada	abierta	
010101302721488	2"	51	92	120.5	152	17.5	4-19	203	200	9	322	341	18.5
010101302721489	2.1/2"	64	105	139.5	178	19.5	4-19	216	250	10	349	372	26.9
010101302721490	3"	76	127	152.5	190	20.5	4-19	241	250	11	365	391	35.3
010101302721491	4"	102	157	190.5	229	24	8-19	292	300	11.5	423	457	51.1
-	5"	127	186	216	254	24	8-22	356	350	12	458	500	71
010101302721492	6"	152	216	241.5	279	26	8-22	406	350	12	481	534	91.5

GLOBO 150LBS 2" - 6" BW

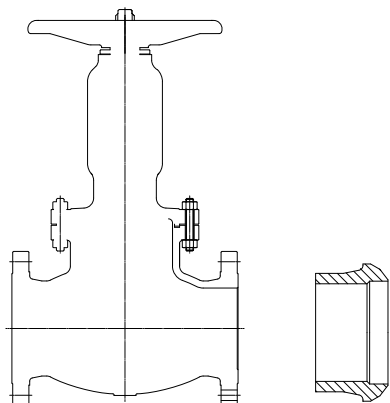

Globo Fig. GL01013XU		Clase: 150LBS
VÁLVULA GLOBO ACERO CARBONO 150LBS BW		
Especificaciones		
Material	Acero carbono ASTM A216 WCB ¹	
Diseño	BS 1873	
Conexiones	Butt Weld según ASME B16.25	
Longitud	ASME B16.10	
Inspección y Pruebas	API 598	
NACE MR 01-75	Bajo demanda	
Aplicaciones	Refinerías, Petroquímica, Química, Metalurgia, Papel, Farmacéuticas...	
¹ Ver lista de materiales estándar		

Componentes		
Pos.	Denominación	Material
1	Cuerpo	ASTM A216 WCB
2	Asientos	ASTM A105 +Cr13
3	Obturador	ASTM A105 +Stellite
4	Husillo	ASTM A182 F6a CL3
5	Junta	Espirometálica Grafito/Ac.inox.
6	Tapa	ASTM A216 WCB
7	Espárrago	ASTM A193 B7
8	Tuerca	ASTM A194 2H
9	Cierre trasero	ASTM A276 410
10	Empaquetadura	Grafito flexible
11	Pasador	ASTM A29 1035
12	Tornillo	ASTM A193 B7
13	Tuerca	ASTM A194 2H
14	Prensaestopas	ASTM A276 410
15	Brida prensaestopas	ASTM A216 WCB
16	Tuerca husillo	ASTM A439 D-2
17	Tornillo	ASTM A29 1035
18	Volante	ASTM A536 60-40-18
19	Arandela	ASTM A36
20	Tuerca	ASTM A36
21	Empaquetadura	Grafito/Acero inox.
22	Pasador	ASTM A36
23	Tuerca obturador	ASTM A182 F6 CL1
24	Chapa identificación	ASTM A240 321
25	Remache	ASTM A276 321
26	Pletina empuje	ASTM A276 420
27	Arandela	ASTM A276 304
28	Lengüetas	ASTM A105
29	Lengüetas	ASTM A105

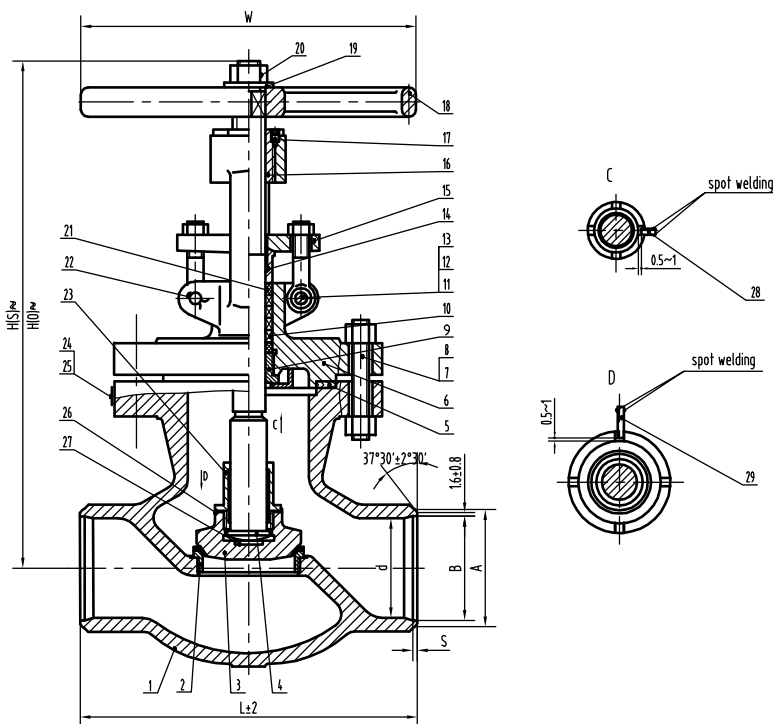

FIG. GL01013XU - GLOBO WCB/F6 XU TRIM N° 8 - 150LBS BW

DN	d	A	SCH 10		SCH 30		SCH 40 (STD)		SCH 80 (XS)		L	W	H(S)	H(O)	Peso (kg)
			B	S	B	S	B	S	B	S					
2"	51	62	55	5	54	5	52.5	6	49	9	203	200	322	341	14.6
2.1/2"	64	75	67	5	63.5	8	62.5	8	59	11	216	250	349	372	20.9
3"	76	91	83	5	79.5	8	78	9	73.5	12	241	250	365	391	28.4
4"	102	117	108	5	104.5	8	102	10	97	13	292	300	423	457	40.6
5"	127	144	134.5	6			128	10	122	15	356	350	458	500	58.5
6"	152	172	161.5	6			154	11	146.5	17	406	350	481	534	76.2

VÁLVULAS FUNDIDAS ANSI

GLOBO 150LBS 8" - 12" BRIDAS

Globo Fig. GL01011XU		Clase: 150LBS
VÁLVULA GLOBO ACERO CARBONO 150LBS BRIDAS		
Especificaciones		
Material	Acero carbono ASTM A216 WCB ¹	
Diseño	BS 1873	
Conexiones	Bridas según ASME B16.5 RF	
Longitud	ASME B16.10	
Inspección y Pruebas	API 598	
NACE MR 01-75	Bajo demanda	
Aplicaciones	Refinerías, Petroquímica, Química, Metalurgia, Papel, Farmacéuticas...	
¹ Ver lista de materiales estándar		

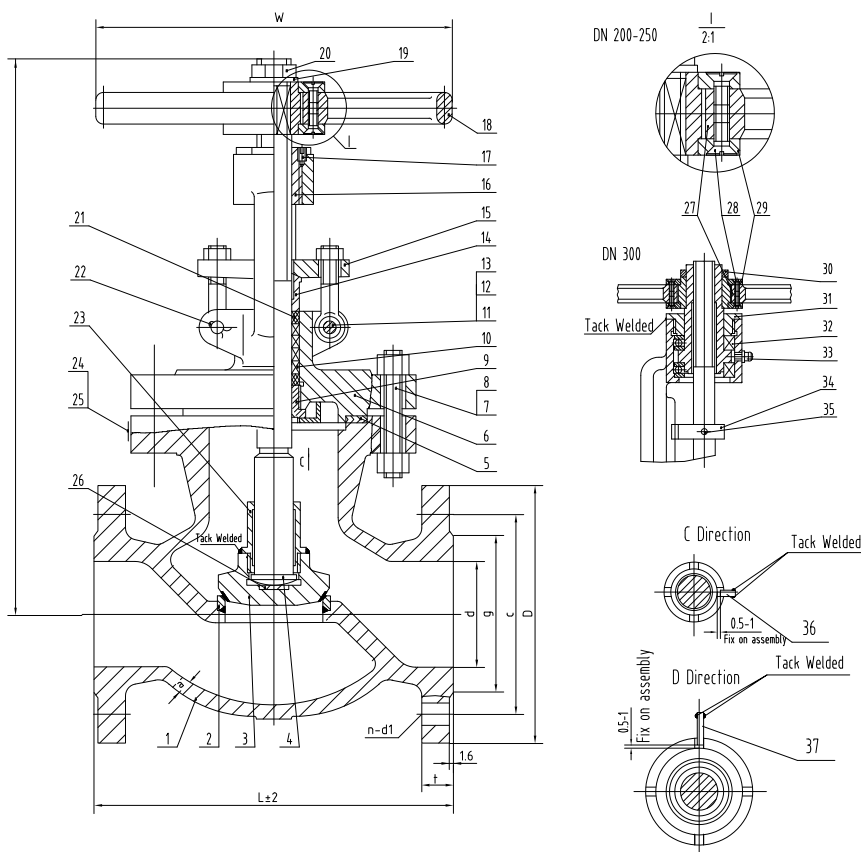
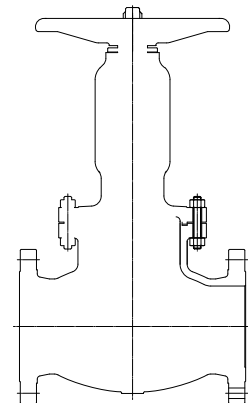

Componentes		
Pos.	Denominación	Material
1	Cuerpo	ASTM A216 WCB
2	Asientos	ASTM A105 +ER410
3	Disco	ASTM A105 +Stellite
4	Husillo	ASTM A182 F6a
5	Junta	Espirometalica Grafito/Ac.inox.
6	Tapa	ASTM A216 WCB
7	Tuerca	ASTM A194 2H
8	Espárrago	ASTM A193 B7
9	Cierre trasero	ASTM A276 410
10	Empaquetadura	Grafito
11	Pasador	ASTM A29 1035
12	Tornillo de ojo	ASTM A193 B7
13	Tuerca	ASTM A194 2H
14	Prensaestopas	ASTM A276 410
15	Brida prensaestopas	ASTM A216 WCB
16	Tuerca husillo	ASTM A439 D-2
17	Tornillo	ASTM A29 1035
18	Volante	ASTM 536 60-40-18
19	Arandela	ASTM A36
20	Tuerca volante	ASTM A36
21	Empaquetadura	Grafito/Acero inox.
22	Pasador	ASTM A36
23	Tapa disco	ASTM A276 410
24	Placa identificación	ASTM A240 321
25	Remache	ASTM A276 321
26	Arandela empuje	ASTM A276 420
27	Camisa impacto	ASTM A29 1045
28	Tornillo	ASTM A29 1035
29	Tapa volante	ASTM A36
30	Tuerca volante	ASTM A29 1035
31	Tuerca retén	ASTM A29 1035
32	Cojinete	
33	Lubricador	ASTM A36
34	Pletina guía	ASTM A29 1045
35	Pasador	ASTM A276 410
36	Pletina	ASTM A29 1025
37	Pletina	ASTM A29 1025

FIG. GL01011XU - GLOBO WCB/F6 XU TRIM N° 8 - 150LBS RF

Código	DN	d	g	C	D	t	n-d1	L	W	a	H		Peso (kg)
											cerrada	abierta	
010101302721493	8"	203	270	298.5	343	29	8-22	495	400	13	552	616	141.3
-	10"	254	324	362	406	31	12-25	622	450	14	643	721	216.2
-	12"	305	381	432	483	32	12-25	699	560	16	857	949	347.1

GLOBO 150LBS 8" BW

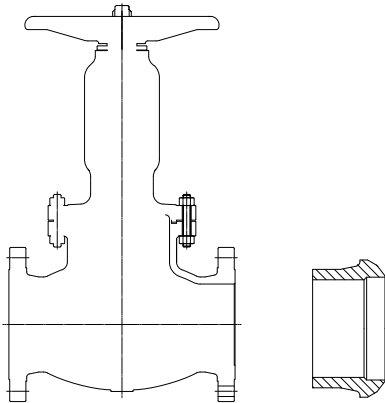

Globo Fig. GL01013XU		Clase: 150LBS
VÁLVULA GLOBO ACERO CARBONO 150LBS BW		
Especificaciones		
Material	Acero carbono ASTM A216 WCB ¹	
Diseño	BS 1873	
Conexiones	Butt Weld según ASME B16.25	
Longitud	ASME B16.10	
Inspección y Pruebas	API 598	
NACE MR 01-75	Bajo demanda	
Aplicaciones	Refinerías, Petroquímica, Química, Metalurgia, Papel, Farmacéuticas...	
¹ Ver lista de materiales estándar		

Componentes		
Pos.	Denominación	Material
1	Cuerpo	ASTM A216 WCB
2	Asientos	ASTM A105 +Stellite
3	Obturador	ASTM A105 +Stellite
4	Husillo	ASTM A182 F6a CL3
5	Junta	Espirometálica Grafito/Ac.inox.
6	Tapa	ASTM A216 WCB
7	Espárrago	ASTM A193 B7
8	Tuerca	ASTM A194 2H
9	Cierre trasero	ASTM A276 410
10	Empaquetadura	Grafito flexible
11	Pasador	ASTM A29 1035
12	Tornillo	ASTM A193 B7
13	Tuerca	ASTM A194 2H
14	Prensaestopas	ASTM A276 410
15	Brida prensaestopas	ASTM A216 WCB
16	Tuerca husillo	ASTM A439 D-2
17	Tornillo	ASTM A29 1035
18	Volante	ASTM A216 WCB
19	Arandela	ASTM A36
20	Tuerca retén	ASTM A29 1045
21	Empaquetadura	Grafito/Acero inox.
22	Pasador	ASTM A36
23	Tuerca obturador	ASTM A276 410
24	Chapa identificación	ASTM A240 321
25	Remache	ASTM A276 321
26	Arandela	ASTM A276 304
27	Pletina empuje	ASTM A276 420
28	Casquillo impacto	ASTM A29 1045
29	Tornillo	ASTM A29 1035
30	Tapa volante	ASTM A36
31	Lengüetas	ASTM A105
32	Lengüetas	ASTM A105

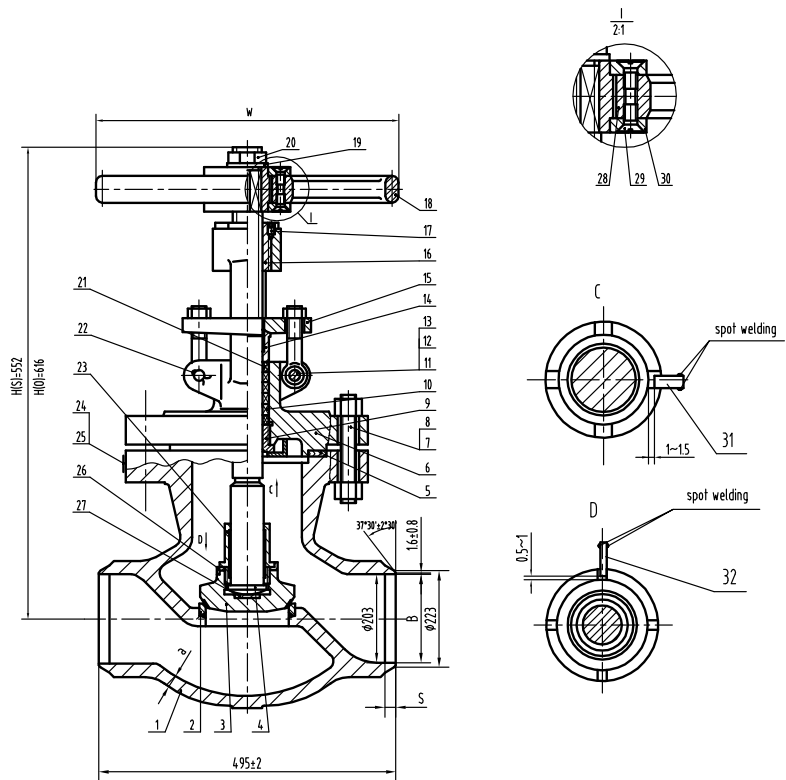

FIG. GL01013XU - GLOBO WCB/F6 XU TRIM N° 8 - 150LBS BW

DN	SCH 10		SCH 20		SCH 30		SCH 40 (STD)		SCH 60		SCH 80 (XS)	
	B	S	B	S	B	S	B	S	B	S	B	S
8"	211.5	6	206.5	10	205	11	203	13	198.5	16	193.5	20

VÁLVULAS FUNDIDAS ANSI

GLOBO 150LBS 14" - 24" BRIDAS CON REDUCTOR

Globo		Clase: 150LBS
VÁLVULA GLOBO ACERO CARBONO 150LBS BRIDAS		
Especificaciones		
Material	Acero carbono ASTM A216 WCB ¹	
Diseño	BS 1873	
Conexiones	Bridas según ASME B16.5 RF	
Longitud	ASME B16.10	
Inspección y Pruebas	API 598	
NACE MR 01-75	Bajo demanda	
Aplicaciones	Refinerías, Petroquímica, Química, Metalurgia, Papel, Farmacéuticas...	
¹ Ver lista de materiales estándar		

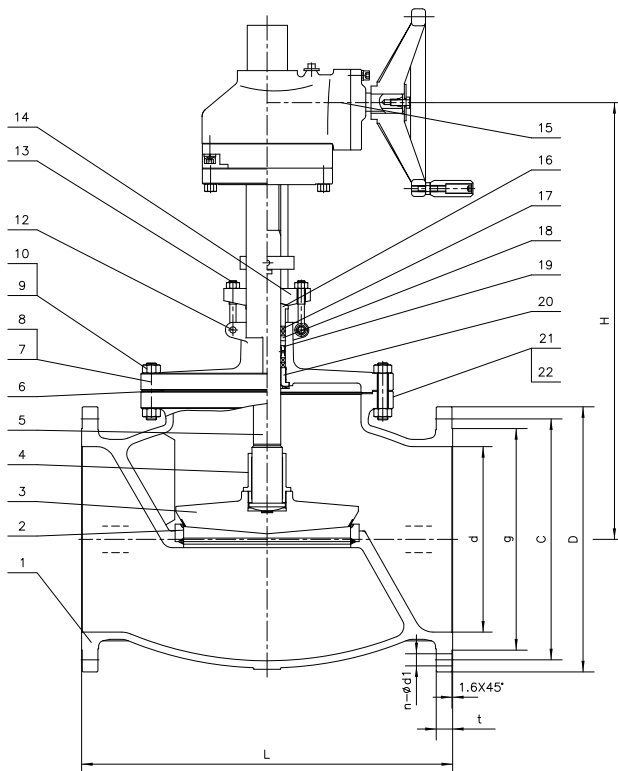
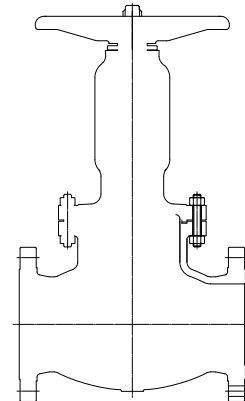

Componentes			
Pos.	Denominación	Cant.	Material
1	Cuerpo	1	ASTM A216 WCB
2	Asientos	1	ASTM A105 +Stellite
3	Disco	1	ASTM A105 +13Cr
4	Tapa disco	1	ASTM A182 F6a
5	Husillo	1	ASTM A276 410
6	Junta cuerpo-tapa	1	Spirom. 304/Grafito
7	Tapa	1	ASTM A216 WCB
8	Tornillo cuerpo-tapa		ASTM A193 B7
9	Tuerca cuerpo-tapa		ASTM A194 2H
10	Pasador	2	ASTM A108 1035
12	Tornillo de ojo	2	ASTM A193 B7
13	Tuerca	2	ASTM A194 2H
14	Brida prensaestopas	1	ASTM A216 WCB
15	Reductor	1	
16	Prensaestopas	1	ASTM A276 410
17	Empaquetadura	2	Grafito
18	Empaquetadura	4-5	Grafito flexible
19	Back seat	1	ASTM A276 410
20	Remache	2	304SS
21	Placa identificación	1	304SS

GLOBO WCB/F6 XU TRIM N° 8 - 150LBS RF

Código	DN	d	L	D	C	g	t	n	d1	H	Peso (kg)
-	14"	337	787	533	476	413	35	12	29	915	
-	16"	387	914	597	539,5	470	37	16	29	1.009	695
-	18"	438	978	635	578	533	40	16	32	1.170	1.150
-	20"	498	978	699	635	584	43	20	32	1.130	1.097
-	24"	591	1.295	813	749,5	692	48	20	35	1.288	1.678

GLOBO 300LBS 2" - 4" BRIDAS

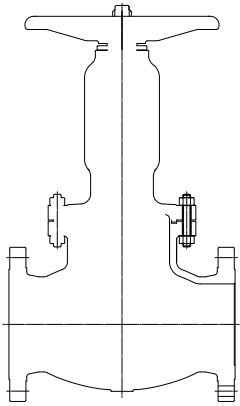

Globo Fig. GL03011XU		Clase: 300LBS
VÁLVULA GLOBO ACERO CARBONO 300LBS BRIDAS		
Especificaciones		
Material	Acero carbono ASTM A216 WCB ¹	
Diseño	BS 1873	
Conexiones	Bridas según ASME B16.5 RF	
Longitud	ASME B16.10	
Inspección y Pruebas	API 598	
NACE MR 01-75	Bajo demanda	
Aplicaciones	Refinerías, Petroquímica, Química, Metalurgia, Papel, Farmacéuticas...	
¹ Ver lista de materiales estándar		

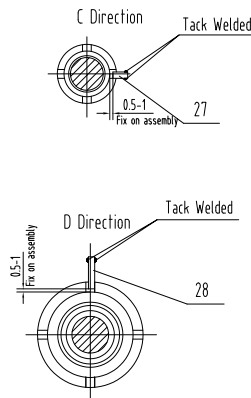
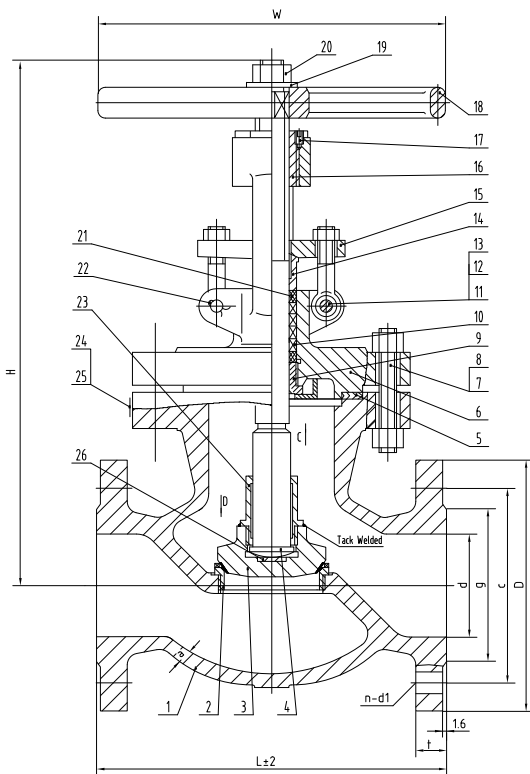

Componentes		
Pos.	Denominación	Material
1	Cuerpo	ASTM A216 WCB
2	Asientos	ASTM A105 +Stellite
3	Disco	ASTM A105 +ER410
4	Husillo	ASTM A182 F6a
5	Junta	Espirometalica Grafito/Ac.inox.
6	Tapa	ASTM A216 WCB
7	Tuerca	ASTM A194 2H
8	Espárrago	ASTM A193 B7
9	Cierre trasero	ASTM A276 410
10	Empaquetadura	Grafito
11	Pasador	ASTM A29 1035
12	Tornillo de ojo	ASTM A193 B7
13	Tuerca	ASTM A194 2H
14	Prensaestopas	ASTM A276 410
15	Brida prensaestopas	ASTM A216 WCB
16	Tuerca husillo	ASTM A439 D-2
17	Tornillo	ASTM A29 1035
18	Volante	ASTM 536 60-40-18
19	Arandela	ASTM A36
20	Tuerca volante	ASTM A36
21	Empaquetadura	Grafito/Acero inox.
22	Linterna	ASTM A276 410
23	Pasador	ASTM A36
24	Tapa disco	ASTM A276 410
25	Placa identificación	ASTM A240 321
26	Remache	ASTM A276 321
27	Arandela empuje	ASTM A276 420
28	Lengüeta	ASTM A29 1025
29	Lengüeta	ASTM A29 1025

FIG. GL03011XU - GLOBO WCB/F6 XU TRIM N° 8 - 300LBS RF

Código	DN	d	g	C	D	t	n-d1	L	W	a	H		Peso (kg)
											cerrada	abierta	
010101302721494	2"	51	92	127	165	23	8-19	267	200	9.5	359	378	23.6
010101302721691	2.1/2"	64	105	149	190	26	8-22	292	250	11.1	399	422	37.5
010101302721495	3"	76	127	168.5	210	29	8-22	318	250	11.9	417	443	47.1
010101302721496	4"	102	157	200	254	32	8-22	356	350	12.7	503	537	73.6

VÁLVULAS FUNDIDAS ANSI

GLOBO 300LBS 2" - 4" BW

Globo		Clase: 300LBS
VÁLVULA GLOBO ACERO CARBONO 300LBS BW		
Especificaciones		
Material	Acero carbono ASTM A216 WCB ¹	
Diseño	BS 1873	
Conexiones	Butt Weld según ASME B16.25	
Longitud	ASME B16.10	
Inspección y Pruebas	API 598	
NACE MR 01-75	Bajo demanda	
Aplicaciones	Refinerías, Petroquímica, Química, Metalurgia, Papel, Farmacéuticas...	
¹ Ver lista de materiales estándar		

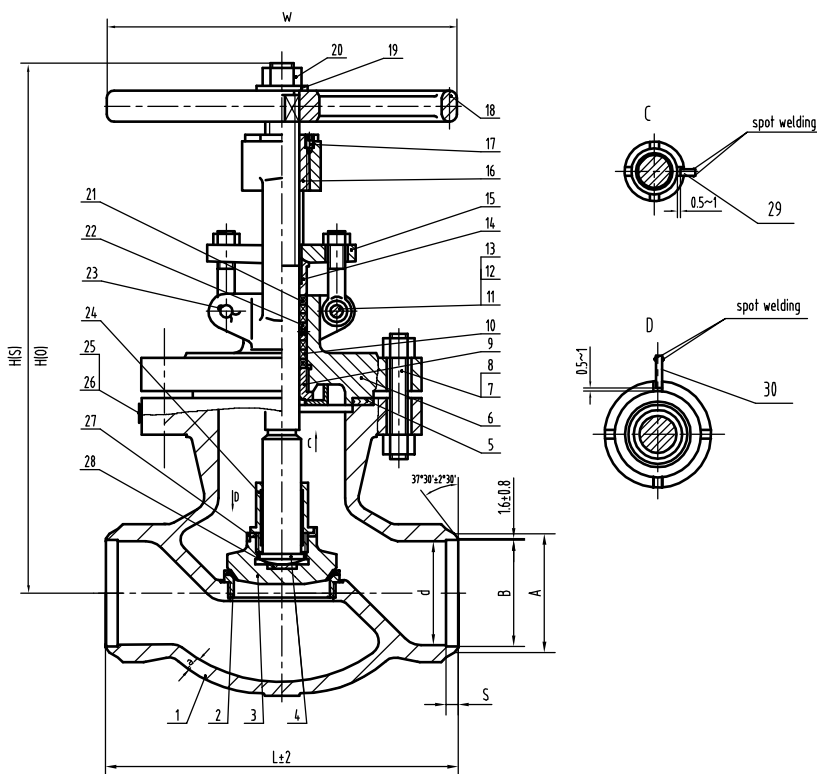
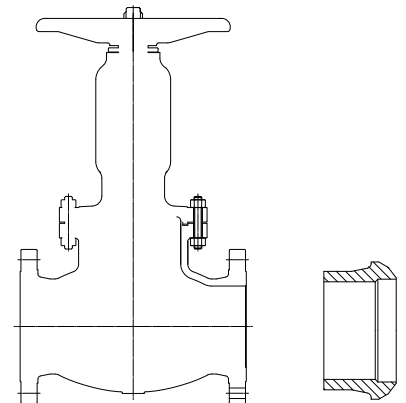

Componentes		
Pos.	Denominación	Material
1	Cuerpo	ASTM A216 WCB
2	Asientos	ASTM A105 +Cr13
3	Obturador	ASTM A105 +Stellite
4	Husillo	ASTM A182 F6a CL3
5	Junta	Espirometálica Grafito/Ac.inox.
6	Tapa	ASTM A216 WCB
7	Espárrago	ASTM A193 B7
8	Tuerca	ASTM A194 2H
9	Cierre trasero	ASTM A276 410
10	Empaquetadura	Grafito flexible
11	Pasador	ASTM A29 1035
12	Tornillo	ASTM A193 B7
13	Tuerca	ASTM A194 2H
14	Prensaestopas	ASTM A276 410
15	Brida prensaestopas	ASTM A216 WCB
16	Tuerca husillo	ASTM A439 D-2
17	Tornillo	ASTM A29 1035
18	Volante	ASTM A536 60-40-18
19	Arandela	ASTM A36
20	Tuerca retén	ASTM A29 1035
21	Empaquetadura	Grafito/Acero inox.
22	Linterna	ASTM A276 410
23	Pasador	ASTM A36
24	Tuerca obturador	ASTM A182 F6a CL1
25	Chapa identificación	ASTM A240 321
26	Remache	ASTM A276 321
27	Arandela	ASTM A276 304
28	Pletina empuje	ASTM A276 420
29	Lengüetas	ASTM A105
30	Lengüetas	ASTM A105

GLOBO WCB/F6 XU TRIM Nº 8 - 150LBS BW

DN	d	A	SCH 40		SCH 80		L	W	A	H(S)	H(O)	Peso (kg)
			B	S	B	S						
2"	51	60.3	525	6	49	9	267	200	9.5	359	378	19.6
2.1/2"	64	75	625	8	59	11	292	250	11.1	399	422	31.5
3"	76	91	78	9	73.5	12	318	250	11.9	417	443	35.8
4"	102	117	102	10	97	13	356	350	12.7	503	537	53.8

GLOBO 300LBS 5" - 8" BRIDAS

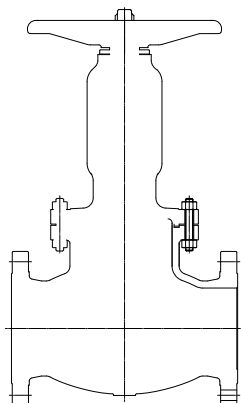

Globo Fig. GL03011XU		Clase: 300LBS
VÁLVULA GLOBO ACERO CARBONO 300LBS BRIDAS		
Especificaciones		
Material	Acero carbono ASTM A216 WCB ¹	
Diseño	BS 1873	
Conexiones	Bridas según ASME B16.5 RF	
Longitud	ASME B16.10	
Inspección y Pruebas	API 598	
NACE MR 01-75	Bajo demanda	
Aplicaciones	Refinerías, Petroquímica, Química, Metalurgia, Papel, Farmacéuticas...	
¹ Ver lista de materiales estándar		

Componentes		
Pos.	Denominación	Material
1	Cuerpo	ASTM A216 WCB
2	Asientos	ASTM A105 +ER410
3	Disco	ASTM A105 +Stellite
4	Husillo	ASTM A182 F6a
5	Junta	Acero inox. / Grafito
6	Tapa	ASTM A216 WCB
7	Tuerca	ASTM A194 2H
8	Espárrago	ASTM A193 B7
9	Cierre trasero	ASTM A276 410
10	Empaquetadura	Grafito
11	Pasador	ASTM A29 1035
12	Tornillo de ojo	ASTM A193 B7
13	Tuerca	ASTM A194 2H
14	Prensaestopas	ASTM A276 410
15	Brida prensaestopas	ASTM A216 WCB
16	Tuerca husillo	ASTM A439 D-2
17	Tornillo	ASTM A29 1035
18	Volante	ASTM A536 60-40-18
19	Arandela	ASTM A36
20	Tuerca volante	ASTM A36
21	Empaquetadura	Acero inox. / Grafito
22	Linterna	ASTM A276 410
23	Pasador	ASTM A36
24	Protección disco	ASTM A276 410
25	Placa identificación	ASTM A240 321
26	Remache	ASTM A276 321
27	Arandela de empuje	ASTM A276 420
28	Camisa impacto	ASTM A29 1045
29	Tornillo	ASTM A29 1035
30	Protección volante	ASTM A36
31	Tuerca volante	ASTM A29 1035
32	Tuerca retén	ASTM A29 1035
33	Cojinete	
34	Lubricador	ASTM A36
35	Guía	ASTM A29 1045
36	Pasador	ASTM A276 410
37	Pletina	ASTM A29 1025
38	Pletina	ASTM A29 1025

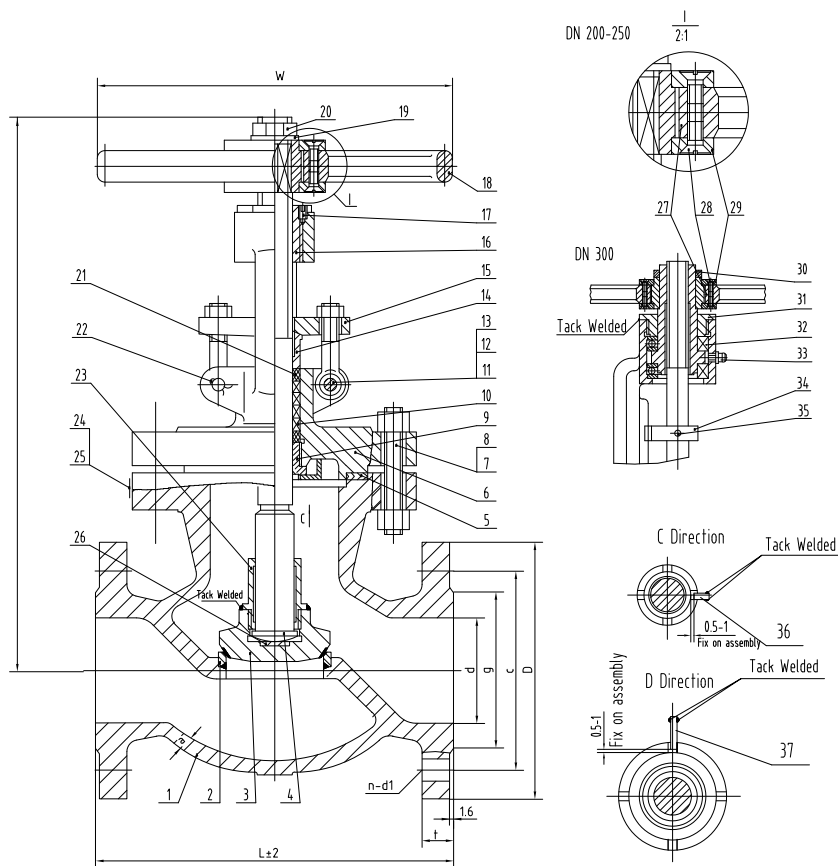

FIG. GL03011XU - GLOBO WCB/F6 XU TRIM N° 8 - 300LBS RF

Código	DN	d	g	C	D	t	n-d1	L	W	a	H		Peso (kg)
											cerrada	abierta	
-	5"	127	186	235	279	35	8-22	400	400	14.5	585	627	109.7
010101302721497	6"	152	216	270	318	37	12-22	444	450	15.9	634	687	145.0
010101302721968	8"	203	270	330	381	42	12-25	559	560	17.4	836	899	256.8

VÁLVULAS FUNDIDAS ANSI

GLOBO 300LBS 5" - 6" BW

Globo		Clase: 300LBS
VÁLVULA GLOBO ACERO CARBONO 300LBS BW		
Especificaciones		
Material	Acero carbono ASTM A216 WCB ¹	
Diseño	BS 1873	
Conexiones	Butt Weld según ASME B16.25	
Longitud	ASME B16.10	
Inspección y Pruebas	API 598	
NACE MR 01-75	Bajo demanda	
Aplicaciones	Refinerías, Petroquímica, Química, Metalurgia, Papel, Farmacéuticas...	
¹ Ver lista de materiales estándar		

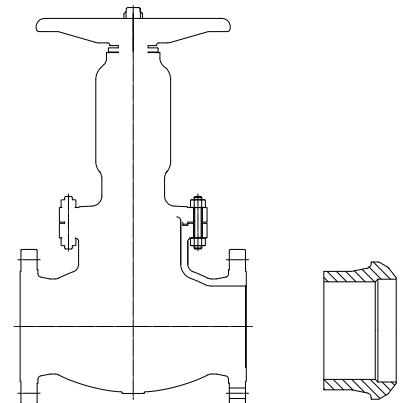

Componentes		
Pos.	Denominación	Material
1	Cuerpo	ASTM A216 WCB
2	Asientos	ASTM A105 +Cr13
3	Obturador	ASTM A105 +Stellite
4	Husillo	ASTM A182 F6a CL3
5	Junta	Espirometálica Grafito/Ac.inox.
6	Tapa	ASTM A216 WCB
7	Espárrago	ASTM A193 B7
8	Tuerca	ASTM A194 2H
9	Cierre trasero	ASTM A276 410
10	Empaquetadura	Grafito flexible
11	Pasador	ASTM A29 1035
12	Tornillo	ASTM A193 B7
13	Tuerca	ASTM A194 2H
14	Prensaestopas	ASTM A276 410
15	Brida prensaestopas	ASTM A216 WCB
16	Tuerca husillo	ASTM A439 D-2
17	Tornillo	ASTM A29 1035
18	Volante	ASTM A536 60-40-18
19	Arandela	ASTM A36
20	Tuerca retén	ASTM A36
21	Empaquetadura	Grafito/Acero inox.
22	Linterna	ASTM A276 410
23	Pasador	ASTM A36
24	Tuerca obturador	ASTM A182 F6a CL1
25	Chapa identificación	ASTM A240 321
26	Remache	ASTM A276 321
27	Arandela	ASTM A276 304
28	Pletina empuje	ASTM A276 420
29	Casquillo impacto	ASTM A29 1045
30	Tornillo	ASTM A29 1035
31	Tapa volante	ASTM A36
32	Lengüetas	ASTM A105
33	Lengüetas	ASTM A105

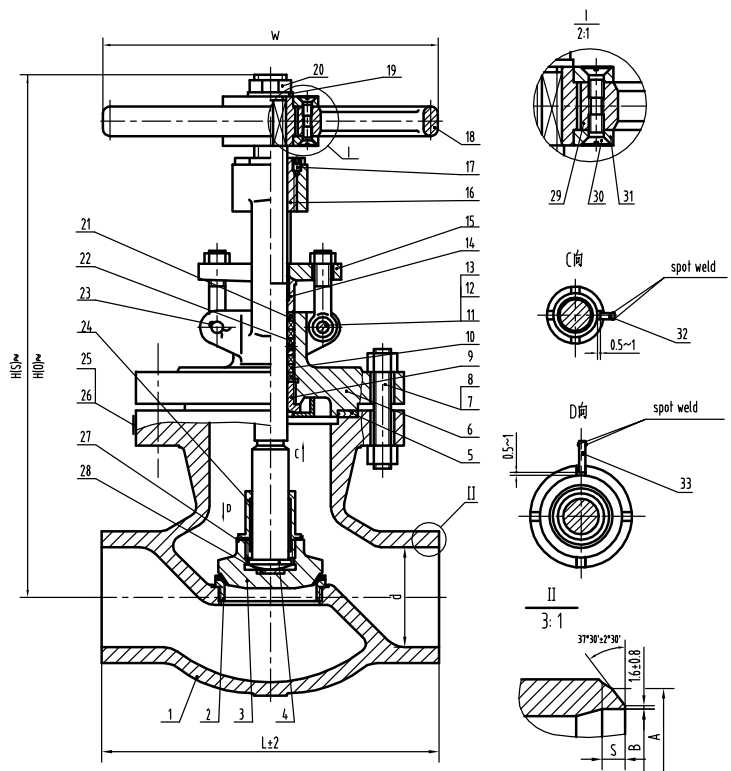

GLOBO WCB/F6 XU TRIM N° 8 - 150LBS BW

DN	d	A	SCH 10		SCH 40 (STD)		SCH 80 (XS)		L	W	H(S)	H(O)	Peso (kg)
			S	B	S	B	S	B					
5"	127	144	6	134.5	10	128	15	122	400	400	585	627	87.6
6"	152	172	6	161.5	11	154	17	146.5	444	450	634	687	116.1

GLOBO 300LBS 8" BW

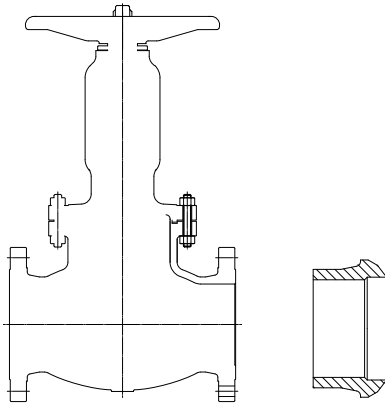

Globo Fig. GL03013XU		Clase: 300LBS
VÁLVULA GLOBO ACERO CARBONO 300LBS BW		
Especificaciones		
Material	Acero carbono ASTM A216 WCB ¹	
Diseño	BS 1873	
Conexiones	Butt Weld según ASME B16.25	
Longitud	ASME B16.10	
Inspección y Pruebas	API 598	
NACE MR 01-75	Bajo demanda	
Aplicaciones	Refinerías, Petroquímica, Química, Metalurgia, Papel, Farmacéuticas...	
¹ Ver lista de materiales estándar		

Componentes		
Pos.	Denominación	Material
1	Cuerpo	ASTM A216 WCB
2	Asientos	ASTM A105 +Cr13
3	Disco	ASTM A105 +Stellite
4	Husillo	ASTM A182 F6a CL3
5	Junta	Acero inox. / Grafito
6	Tapa	ASTM A216 WCB
7	Espárrago	ASTM A193 B7
8	Tuerca	ASTM A194 2H
9	Cierre trasero	ASTM A276 410
10	Empaquetadura	Grafito flexible
11	Pasador	ASTM A29 1035
12	Tornillo	ASTM A193 B7
13	Tuerca	ASTM A194 2H
14	Prensaestopas	ASTM A276 410
15	Brida prensaestopas	ASTM A216 WCB
16	Tuerca husillo	ASTM A439 D-2
17	Volante	ASTM A216 WCB
18	Empaquetadura	Grafito / Acero inox.
19	Linterna	ASTM A276 410
20	Pasador	ASTM A36
21	Tuerca obturador	ASTM A182 F6a CL1
22	Chapa identificación	ASTM A240 321
23	Remache	ASTM A276 321
24	Arandela	ASTM A276 304
25	Pletina empuje	ASTM A276 420
26	Tuerca retén	ASTM A29 1035
27	Casquillo impacto	ASTM A29 1045
28	Tornillo	ASTM A29 1035
29	Tapa volante	ASTM A36
30	Tuerca prensaestopas	ASTM A29 1035
31	Cojinete	
32	Engrasador	ASTM A36
33	Pletina guía	ASTM A29 1045
34	Pasador	ASTM A29 4142
35	Lengüetas	ASTM A105

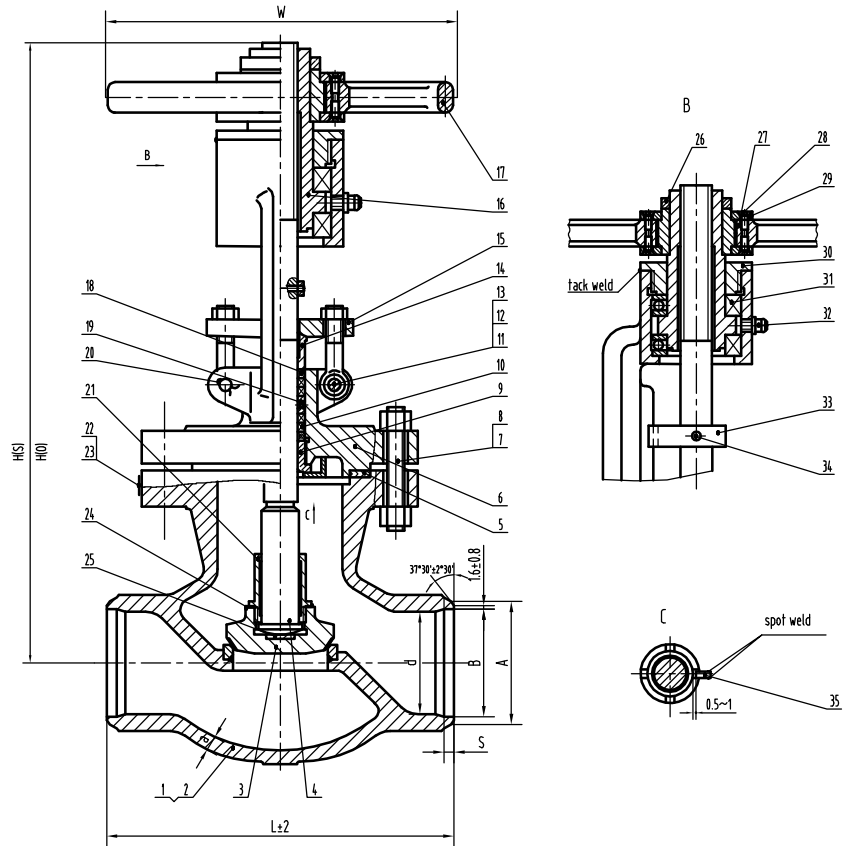

FIG. GL03013XU - GLOBO WCB/F6 XU TRIM N° 8 - 300LBS BW

DN	d	A	SCH 40		SCH 80		SCH XS		L	W	a	H(S)	H(O)	Peso (kg)
			B	S	B	S	B	S						
6"	203	223	203	13	193.5	20			559	560	17.4	836	899	256.8

VÁLVULAS FUNDIDAS ANSI

GLOBO 300LBS 10" - 12" BRIDAS CON REDUCTOR

Globo Fig. GL03011XU		Clase: 300LBS
VÁLVULA GLOBO ACERO CARBONO 300LBS BRIDAS		
Especificaciones		
Material	Acero carbono ASTM A216 WCB ¹	
Diseño	BS 1873	
Conexiones	Bridas según ASME B16.5 RF	
Longitud	ASME B16.10	
Inspección y Pruebas	API 598	
NACE MR 01-75	Bajo demanda	
Aplicaciones	Refinerías, Petroquímica, Química, Metalurgia, Papel, Farmacéuticas...	
¹ Ver lista de materiales estándar		

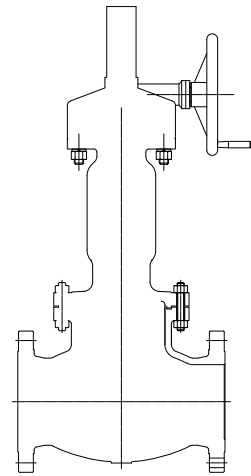

Componentes		
Pos.	Denominación	Material
1	Cuerpo	ASTM A216 WCB
2	Asientos	ASTM A105 +ER410
3	Disco	ASTM A105 +Stellite
4	Husillo	ASTM A182 F6a
5	Junta	Acero inox. / Grafito
6	Tapa	ASTM A216 WCB
7	Tuerca	ASTM A194 2H
8	Espárrago	ASTM A193 B7
9	Cierre trasero	ASTM A276 410
10	Empaquetadura	Grafito
11	Linterna	ASTM A276 410
12	Pasador	ASTM A29 1035
13	Tornillo de ojo	ASTM A193 B7
14	Tuerca	ASTM A194 2H
15	Prensaestopas	ASTM A276 410
16	Brida prensaestopas	ASTM A216 WCB
17	Reductor manual	
18	Tuerca husillo	ASTM A439 D-2
19	Tornillo	ASTM A193 B7
20	Empaquetadura	Acero inox. / Grafito
21	Pasador	ASTM A36
22	Protección disco	ASTM A276 410
23	Placa identificación	ASTM A240 321
24	Remache	ASTM A276 321
25	Arandela empuje	ASTM A276 420
26	Guía	ASTM A29 1045
27	Pasador	ASTM A276 410
28	Pletina	ASTM A29 1025

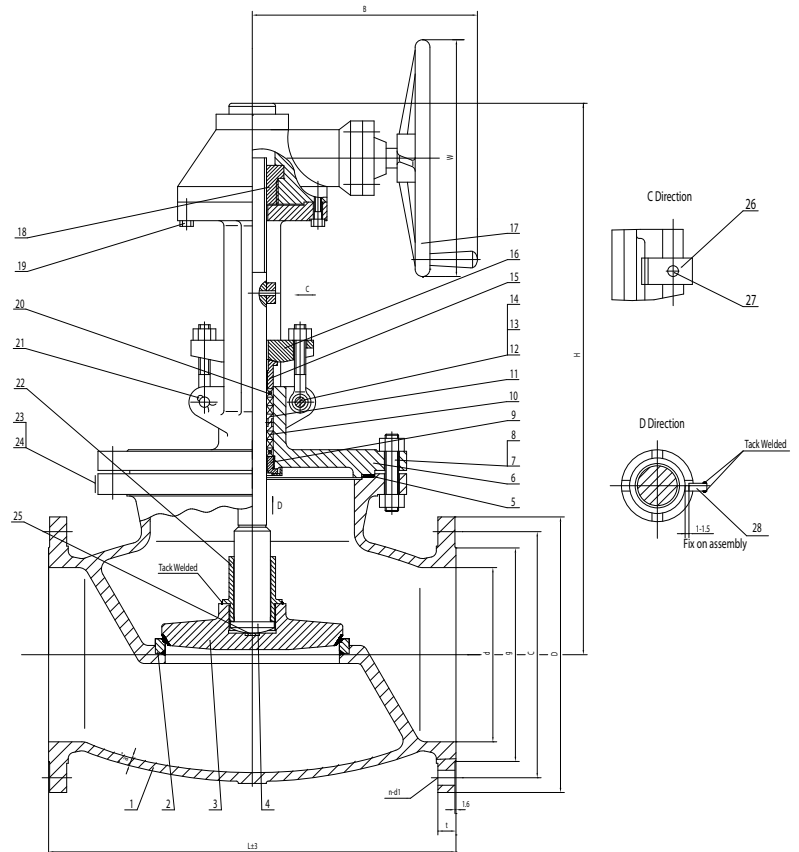
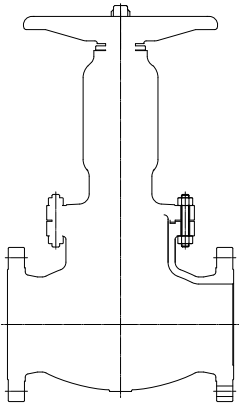

FIG. GL03011XU - GLOBO WCB/F6 XU TRIM N° 8 - 300LBS RF

Código	DN	d	g	C	D	t	n-d1	L	W	a	B	H	Peso (kg)
010101302721995	10"	254	324	387.5	445	48	16-29	622	458	19	507	930	439.8
010101302721450	12"	305	381	451	521	51	16-32	711	610	21	608	1100	801.6

GLOBO 300LBS 14" - 24" BRIDAS CON REDUCTOR



Globo		Clase: 300LBS
VÁLVULA GLOBO ACERO CARBONO 300LBS BRIDAS		
Especificaciones		
Material	Acero carbono ASTM A216 WCB ¹	
Diseño	BS 1873	
Conexiones	Bridas según ASME B16.5 RF	
Longitud	ASME B16.10	
Inspección y Pruebas	API 598	
NACE MR 01-75	Bajo demanda	
Aplicaciones	Refinerías, Petroquímica, Química, Metalurgia, Papel, Farmacéuticas...	
¹ Ver lista de materiales estándar		

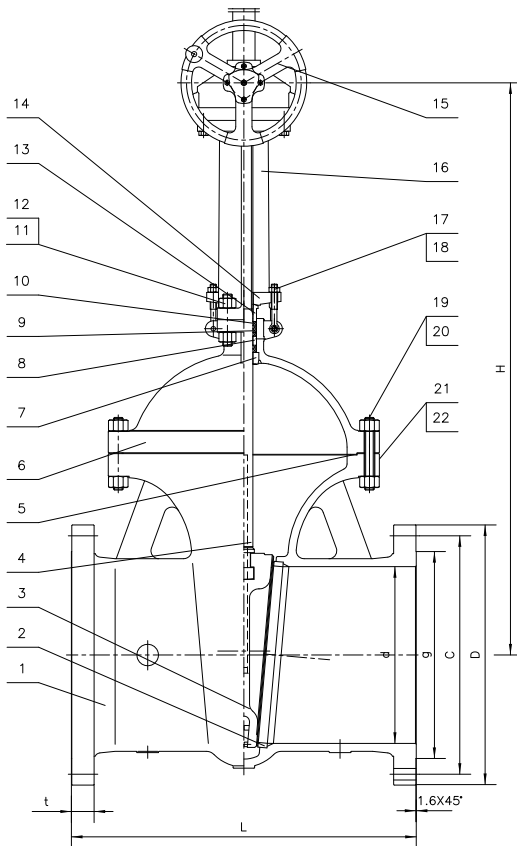

Componentes			
Pos.	Denominación	Cant.	Material
1	Cuerpo	1	ASTM A216 WCB
2	Asientos	1	ASTM A105 +Stellite
3	Disco	1	ASTM A105 +13Cr
4	Tapa disco	1	ASTM A182 F6a
5	Husillo	1	ASTM A276 410
6	Junta cuerpo-tapa	1	Spirom. 304/Grafito
7	Tapa	1	ASTM A216 WCB
8	Tornillo cuerpo-tapa		ASTM A193 B7
9	Tuerca cuerpo-tapa		ASTM A194 2H
10	Pasador	2	ASTM A108 1035
12	Tornillo de ojo	2	ASTM A193 B7
13	Tuerca	2	ASTM A194 2H
14	Brida prensaestopas	1	ASTM A216 WCB
15	Reductor	1	
16	Prensaestopas	1	ASTM A276 410
17	Empaquetadura	2	Grafito
18	Empaquetadura	4-5	Grafito flexible
19	Linterna	1	ASTM A276 410
20	Back seat	1	ASTM A276 410
21	Remache	2	304SS
22	Placa identificación	1	304SS

GLOBO WCB/F6 XU TRIM N° 8 - 300LBS RF

Código	DN	d	L	D	C	g	t	n	d1	H	Peso (kg)
-	14"	337	838	584	514,5	413	54	20	32	930	678
-	16"	387	864	648	571,5	470	58	20	35	1.123	1.252
-	18"	432	978	711	628,5	533	61	24	35	1.227	1.486
	20"	483	1.016	775	686	584	64	24	35	1.350	1.904
	24"	584	1.346	914	813	692	70	24	41	1.525	2.845

VÁLVULAS FUNDIDAS ANSI

GLOBO 600LBS 2" - 3" BRIDAS

Globo Fig. GL06011XU		Clase: 600LBS
VÁLVULA GLOBO ACERO CARBONO 600LBS BRIDAS		
Especificaciones		
Material	Acero carbono ASTM A216 WCB ¹	
Diseño	BS 1873	
Conexiones	Bridas según ASME B16.5 RF	
Longitud	ASME B16.10	
Inspección y Pruebas	API 598	
NACE MR 01-75	Bajo demanda	
Aplicaciones	Refinerías, Petroquímica, Química, Metalurgia, Papel, Farmacéuticas...	
¹ Ver lista de materiales estándar		

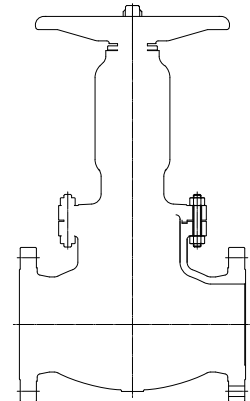

Componentes		
Pos.	Denominación	Material
1	Cuerpo	ASTM A216 WCB
2	Asientos	ASTM A105 +Stellite
3	Disco	ASTM A105 +ER410
4	Husillo	ASTM A182 F6a
5	Junta	Espirometálica Grafito/Ac.inox.
6	Tapa	ASTM A216 WCB
7	Tuerca	ASTM A194 2H
8	Espárrago	ASTM A193 B7
9	Cierre trasero	ASTM A276 410
10	Empaquetadura	Grafito
11	Pasador	ASTM A29 1035
12	Tornillo de ojo	ASTM A193 B7
13	Tuerca	ASTM A194 2H
14	Prensaestopas	ASTM A276 410
15	Brida prensaestopas	ASTM A216 WCB
16	Tuerca husillo	ASTM A439 D-2
17	Tornillo	ASTM A29 1035
18	Volante	ASTM 536 60-40-18
19	Arandela	ASTM A36
20	Tuerca volante	ASTM A36
21	Empaquetadura	Grafito/Acero inox.
22	Linterna	ASTM A276 410
23	Pasador	ASTM A36
24	Tapa disco	ASTM A276 410
25	Placa identificación	ASTM A240 321
26	Remache	ASTM A276 321
27	Arandela empuje	ASTM A276 420
28	Lengüeta	ASTM A29 1025
29	Lengüeta	ASTM A29 1025

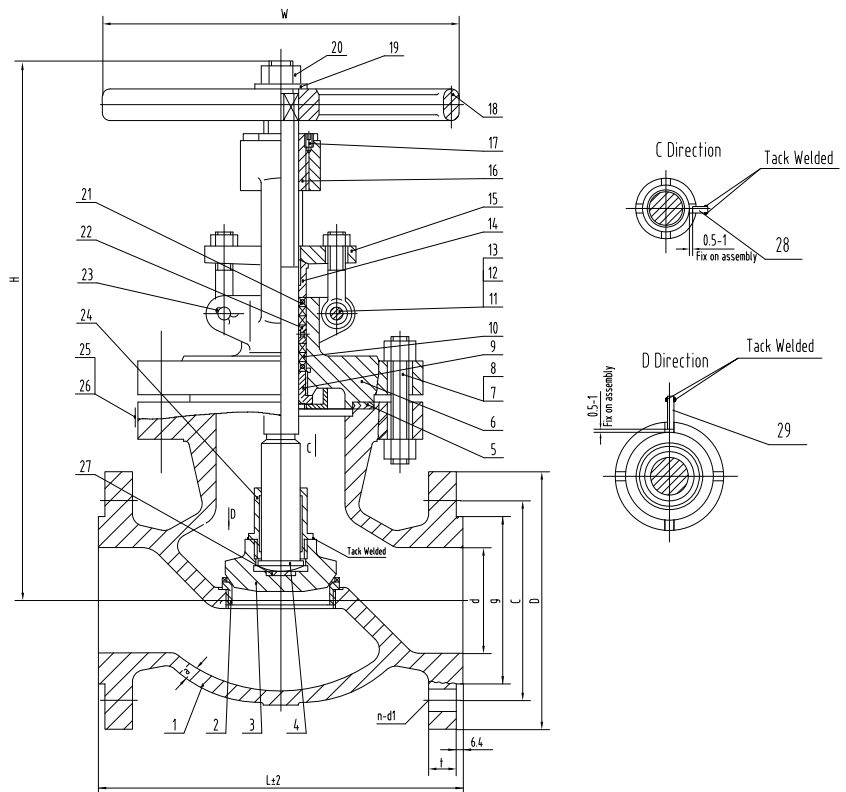
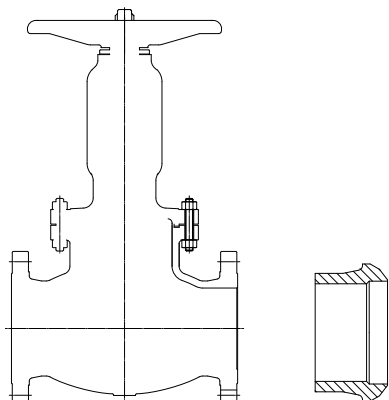

FIG. GL06011XU - GLOBO WCB/F6 XU TRIM N° 8 - 600LBS RF

Código	DN	d	g	C	D	t	n-d1	L	W	a	H		Peso (kg)
											cerrada	abierta	
010101302721460	2"	51	92	127	165	26	8-19	292	250	11.1	414.5	433	35.4
-	2.1/2"	64	105	149	190	29	8-22	330	250	11.9	436.5	459	47
010101302721485	3"	76	127	168	210	32	8-22	356	350	12.7	505.5	532	69.3

GLOBO 600LBS 2" - 3" BW



Globo Fig. GL03013XU		Clase: 600LBS
VÁLVULA GLOBO ACERO CARBONO 600LBS BW		
Especificaciones		
Material	Acero carbono ASTM A216 WCB ¹	
Diseño	BS 1873	
Conexiones	Butt Weld según ASME B16.25	
Longitud	ASME B16.10	
Inspección y Pruebas	API 598	
NACE MR 01-75	Bajo demanda	
Aplicaciones	Refinerías, Petroquímica, Química, Metalurgia, Papel, Farmacéuticas...	
¹ Ver lista de materiales estándar		

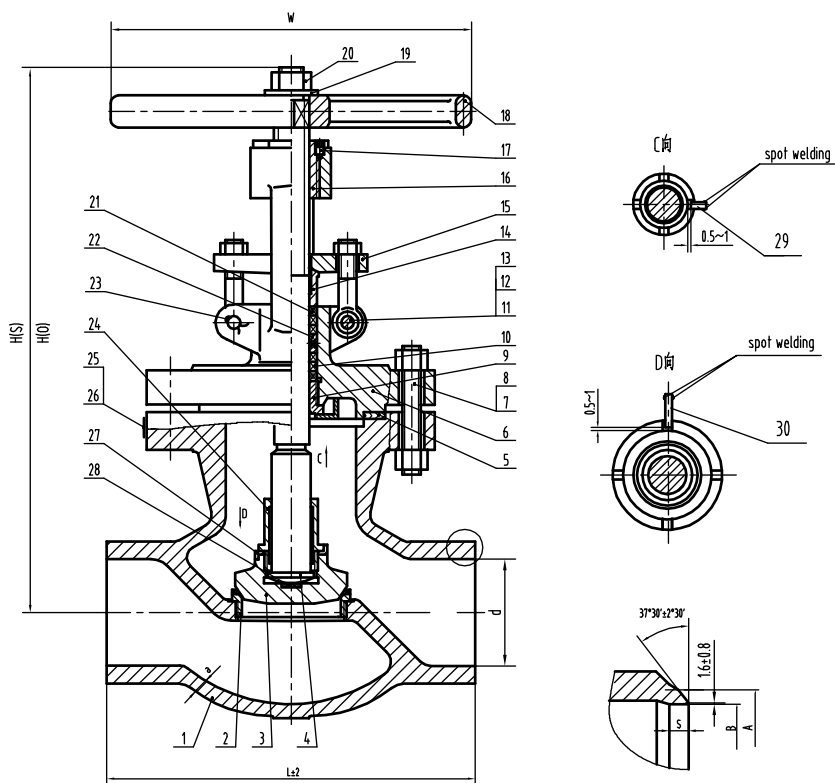

Componentes		
Pos.	Denominación	Material
1	Cuerpo	ASTM A216 WCB
2	Asientos	ASTM A105 +Cr13
3	Obturador	ASTM A105 +Stellite
4	Husillo	ASTM A182 F6a CL3
5	Junta	Acero inox. / Grafito
6	Tapa	ASTM A216 WCB
7	Espárrago	ASTM A193 B7
8	Tuerca	ASTM A194 2H
9	Cierre trasero	ASTM A276 410
10	Empaquetadura	Grafito flexible
11	Pasador	ASTM A29 1035
12	Tornillo	ASTM A193 B7
13	Tuerca	ASTM A194 2H
14	Prensaestopas	ASTM A276 410
15	Brida prensaestopas	ASTM A216 WCB
16	Tuerca husillo	ASTM A439 D-2
17	Tornillo	ASTM A29 1035
18	Volante	ASTM A536 60-40-18
19	Arandela	ASTM A36
20	Tuerca retén	ASTM A194 2H
21	Empaquetadura	Grafito / Acero inox.
22	Linterna	ASTM A276 410
23	Pasador	ASTM A36
24	Tuerca obturador	ASTM A182 F6a CL1
25	Chapa identificación	ASTM A240 321
26	Remache	ASTM A276 321
27	Arandela	ASTM A276 304
28	Pletina empuje	ASTM A276 420
29	Lengüetas	ASTM A276 304
30	Lengüetas	ASTM A276 304

FIG. GL03013XU - GLOBO WCB/F6 XU TRIM N° 8 - 300LBS BW

DN	d	A	SCH 40		SCH 80		L	W	H(S)	H(O)	Peso (kg)
			S	B	S	B					
2"	51	62	6	52.5	9	49	292	250	414.5	433	29.2
2.1/2"	64	75	8	62.5	11	59	330	250	436.5	459	37.9
3"	76	91	9	78	12	73.5	356	350	505.5	532	57.1

VÁLVULAS FUNDIDAS ANSI

GLOBO 600LBS 4" - 6" BRIDAS

Globo Fig. GA06011XU		Clase: 600LBS
VÁLVULA GLOBO ACERO CARBONO 600LBS BRIDAS		
Especificaciones		
Material	Acero carbono ASTM A216 WCB ¹	
Diseño	BS 1873	
Conexiones	Bridas según ASME B16.5 RF	
Longitud	ASME B16.10	
Inspección y Pruebas	API 598	
NACE MR 01-75	Bajo demanda	
Aplicaciones	Refinerías, Petroquímica, Química, Metalurgia, Papel, Farmacéuticas...	
¹ Ver lista de materiales estándar		

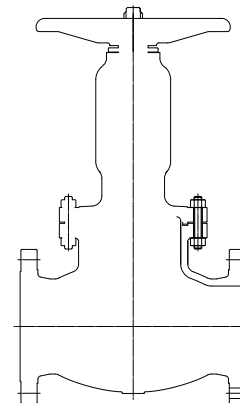

Componentes		
Pos.	Denominación	Material
1	Cuerpo	ASTM A216 WCB
2	Asientos	ASTM A105 +ER410
3	Disco	ASTM A105 +Stellite
4	Husillo	ASTM A182 F6a
5	Junta	Acero inox. / Grafito
6	Tapa	ASTM A216 WCB
7	Tuerca	ASTM A194 2H
8	Espárrago	ASTM A193 B7
9	Cierre trasero	ASTM A276 410
10	Empaquetadura	Grafito
11	Pasador	ASTM A29 1035
12	Tornillo de ojo	ASTM A193 B7
13	Tuerca	ASTM A194 2H
14	Prensaestopas	ASTM A276 410
15	Brida prensaestopas	ASTM A216 WCB
16	Tuerca husillo	ASTM A439 D-2
17	Tornillo	ASTM A29 1035
18	Volante	ASTM A536 60-40-18
19	Arandela	ASTM A36
20	Tuerca volante	ASTM A36
21	Empaquetadura	Acero inox. / Grafito
22	Linterna	ASTM A276 410
23	Pasador	ASTM A36
24	Protección disco	ASTM A276 410
25	Placa identificación	ASTM A240 321
26	Remache	ASTM A276 321
27	Arandela empuje	ASTM A276 420
28	Camisa impacto	ASTM A29 1045
29	Tornillo	ASTM A29 1035
30	Protección volante	ASTM A36
31	Tuerca volante	ASTM A29 1035
32	Tuerca retén	ASTM A29 1035
33	Cojinete	
34	Lubricador	ASTM A36
35	Guía	ASTM A29 1045
36	Pasador	ASTM A276 410
37	Pletina	ASTM A29 1025
38	Pletina	ASTM A29 1025

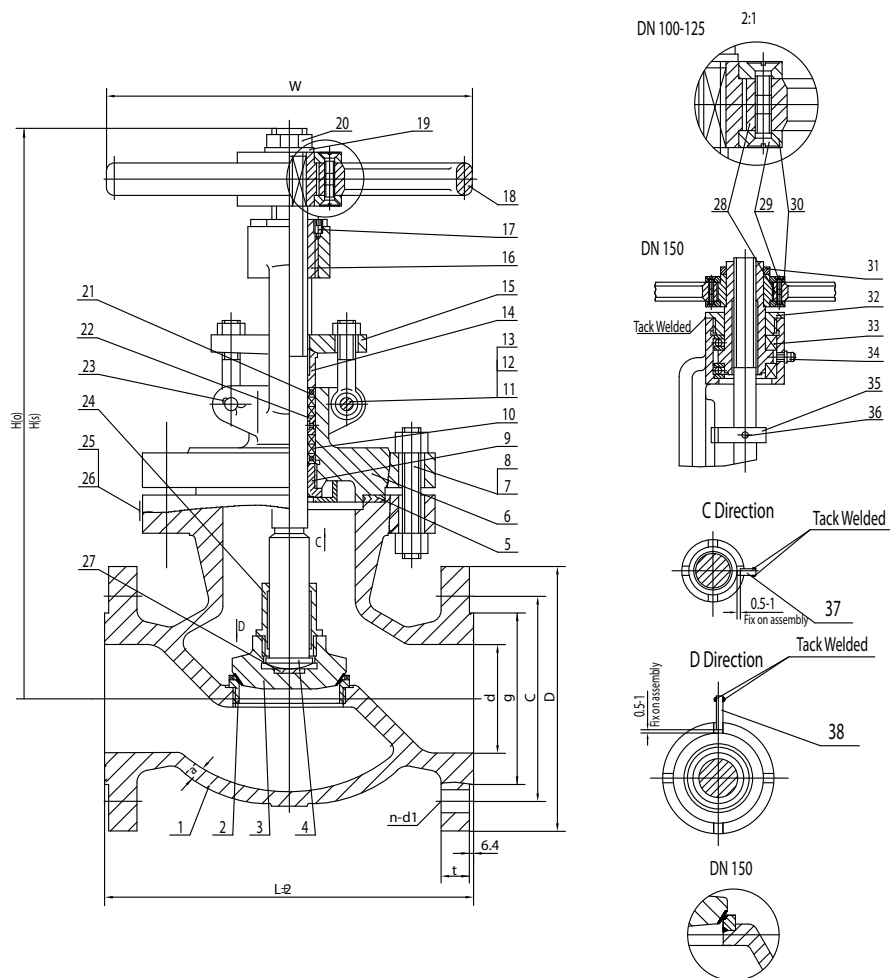
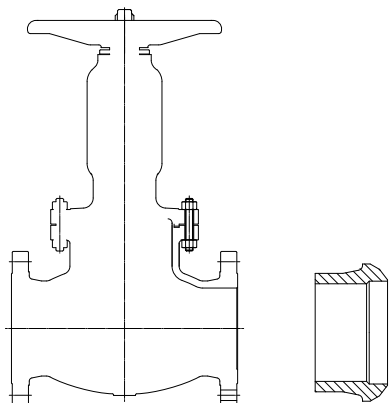

FIG. GL06011XU - GLOBO WCB/F6 XU TRIM N° 8 - 600LBS RF

Código	DN	d	g	C	D	t	n-d1	L	W	a	H(s)	H(o)	Peso (kg)
010101302722055	4"	102	157	216	273	38.1	8-25	432	400	15.9	578	611.5	114.3
-	5"	127	186	266.5	330	45	8-29	508	400	17.5	688	710.5	183.2
010101302722003	6"	152	216	292	356	48	12-29	559	560	19	845	897.5	277.9

GLOBO 600LBS 4" - 6" BW



Globo Fig. GL03013XU		Clase: 600LBS
VÁLVULA GLOBO ACERO CARBONO 600LBS BW		
Especificaciones		
Material	Acero carbono ASTM A216 WCB ¹	
Diseño	BS 1873	
Conexiones	Butt Weld según ASME B16.25	
Longitud	ASME B16.10	
Inspección y Pruebas	API 598	
NACE MR 01-75	Bajo demanda	
Aplicaciones	Refinerías, Petroquímica, Química, Metalurgia, Papel, Farmacéuticas...	
¹ Ver lista de materiales estándar		

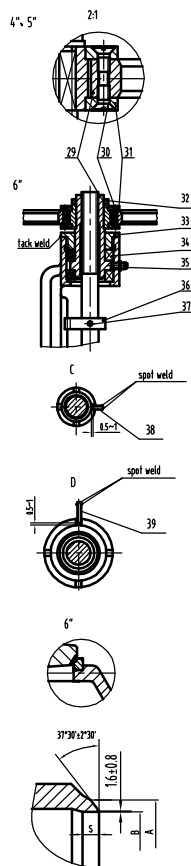
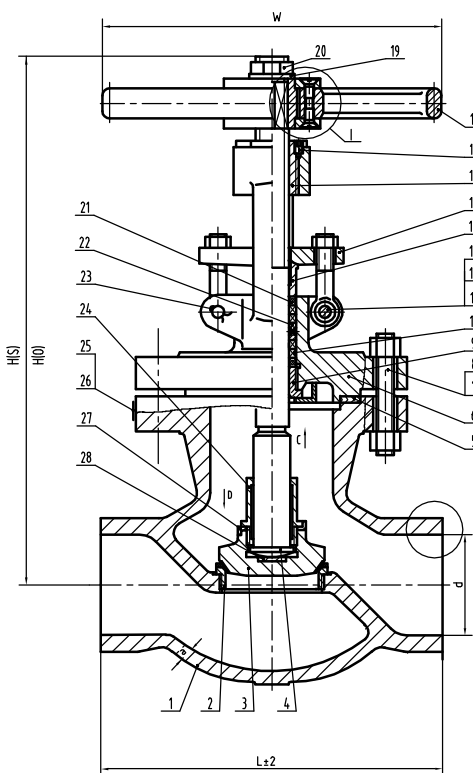

Componentes		
Pos.	Denominación	Material
1	Cuerpo	ASTM A216 WCB
2	Asientos	ASTM A105 +Cr13
3	Obturador	ASTM A105 +Stellite
4	Husillo	ASTM A182 F6a CL3
5	Junta	Acero inox. / Grafito
6	Tapa	ASTM A216 WCB
7	Espárrago	ASTM A193 B7M
8	Tuerca	ASTM A194 2HM
9	Cierre trasero	ASTM A276 410
10	Empaquetadura	Grafito flexible
11	Pasador	ASTM A29 1035
12	Tornillo	ASTM A193 B7
13	Tuerca	ASTM A194 2H
14	Prensaestopas	ASTM A276 410
15	Brida prensaestopas	ASTM A216 WCB
16	Tuerca husillo	ASTM A439 D-2
17	Tornillo	ASTM A29 1035
18	Volante	ASTM A216 WCB
19	Arandela	ASTM A36
20	Tuerca retén	ASTM A29 1035
21	Empaquetadura	Grafito / Acero inox.
22	Linterna	ASTM A276 410
23	Pasador	ASTM A36
24	Tuerca obturador	ASTM A182 F6a CL1
25	Chapa identificación	ASTM A240 321
26	Remache	ASTM A276 321
27	Arandela	ASTM A276 304
28	Pletina empuje	ASTM A276 420
29	Casquillo impacto	ASTM A29 1045
30	Tornillo	ASTM A29 1035
31	Tapa volante	ASTM A36
32	Tuerca retén	ASTM A29 1035
33	Tuerca prensaestopas	ASTM A29 1035
34	Cojinete	
35	Engrasador	ASTM A36
36	Pletina guía	ASTM A29 1045
37	Pasador	ASTM A29 4140
38	Lengüetas	ASTM A105
39	Lengüetas	ASTM A105

FIG. GL03013XU - GLOBO WCB/F6 XU TRIM N° 8 - 600LBS BW

DN	d	A	SCH 40		SCH 80		SCH 120		L	W	a	H(S)	H(O)	Peso (kg)
			B	S	B	S	B	S						
4"	102	117	102	10	97	13	92	17	432	400	15.9	578	611.5	103.8
5"	127	144	128	10	122	5	116	19	508	400	17.5	668	710.5	153.7
6"	152	175	154	11	146.5	17	140	22	559	560	19	845	897.5	199.8

VÁLVULAS FUNDIDAS ANSI

GLOBO 600LBS 6" - 10" BRIDAS CON REDUCTOR

Globo Fig. GL06011XU		Clase: 600LBS
VÁLVULA GLOBO ACERO CARBONO 600LBS BRIDAS		
Especificaciones		
Material	Acero carbono ASTM A216 WCB ¹	
Diseño	BS 1873	
Conexiones	Bridas según ASME B16.5 RF	
Longitud	ASME B16.10	
Inspección y Pruebas	API 598	
NACE MR 01-75	Bajo demanda	
Aplicaciones	Refinerías, Petroquímica, Química, Metalurgia, Papel, Farmacéuticas...	
¹ Ver lista de materiales estándar		

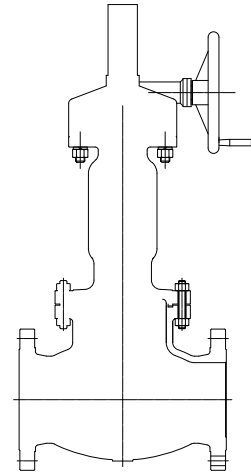

Componentes		
Pos.	Denominación	Material
1	Cuerpo	ASTM A216 WCB
2	Asientos	ASTM A105 +ER410
3	Disco	ASTM A105 +Stellite
4	Husillo	ASTM A182 F6a
5	Junta	Espirometálica Grafito/SS
6	Tapa	ASTM A216 WCB
7	Tuerca	ASTM A194 2H
8	Espárrago	ASTM A193 B7
9	Cierre trasero	ASTM A276 410
10	Empaquetadura	Grafito
11	Linterna	ASTM A276 410
12	Pasador	ASTM A29 1035
13	Tornillo de ojo	ASTM A193 B7
14	Tuerca	ASTM A194 2H
15	Prensaestopas	ASTM A276 410
16	Brida prensa	ASTM A216 WCB
17	Reductor manual	
18	Tuerca husillo	ASTM A439 D-2
19	Tornillo	ASTM A193 B7
20	Empaquetadura	Grafito/Acero inox.
21	Pasador	ASTM A36
22	Tapa Disco	ASTM A276 410
23	Placa identificación	ASTM A240 321
24	Remache	ASTM A276 321
25	Arandela empuje	ASTM A276 420
26	Guía	ASTM A29 1045
27	Pasador	ASTM A276 410
28	Lengüeta	ASTM A29 1025

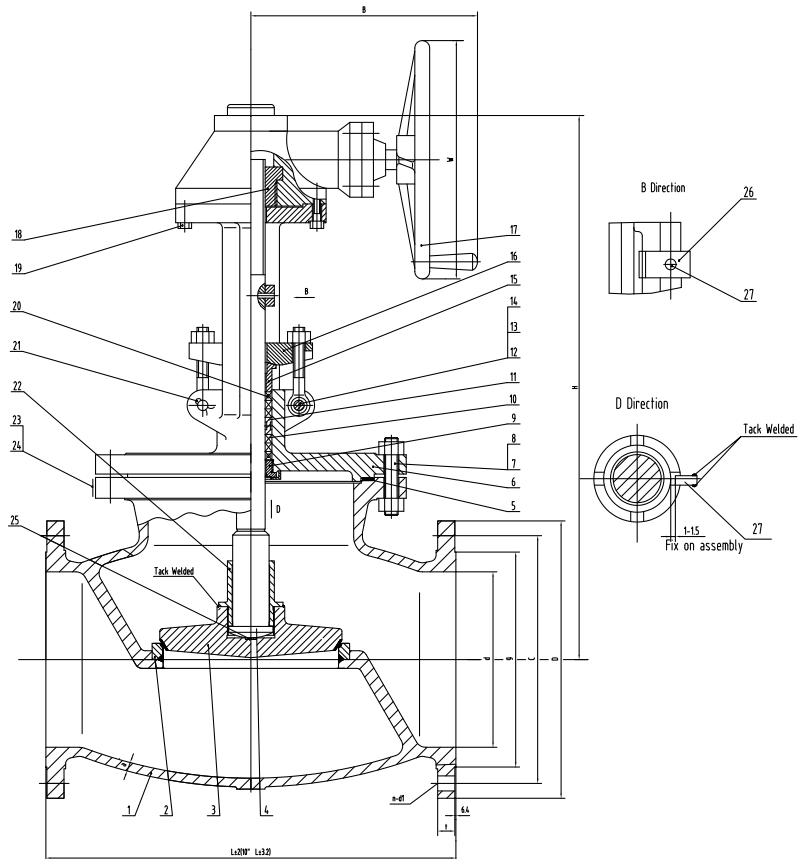
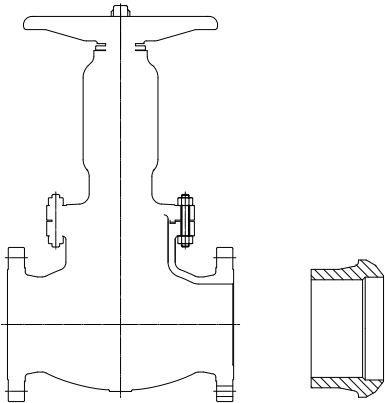

FIG. GL06011XU - GLOBO WCB/F6 XU TRIM N° 8 - 600LBS RF

Código	DN	d	g	C	D	t	n-d1	L	W	a	B	H	Peso (kg)
010101302721967	6"	152	216	292	356	48	12-29	559	458	19	427	779	278.7
-	8"	200	270	349	419	56	12-32	660	458	25.4	507	954	477
-	10"	248	324	432	508	64	16-35	787	610	28.6	608	1149	979.1

GLOBO 600LBS 6" - 8" BW CON REDUCTOR



Globo Fig. GL03013XU		Clase: 600LBS
VÁLVULA GLOBO ACERO CARBONO 600LBS BW		
Especificaciones		
Material	Acero carbono ASTM A216 WCB ¹	
Diseño	BS 1873	
Conexiones	Butt Weld según ASME B16.25	
Longitud	ASME B16.10	
Inspección y Pruebas	API 598	
NACE MR 01-75	Bajo demanda	
Aplicaciones	Refinerías, Petroquímica, Química, Metalurgia, Papel, Farmacéuticas...	
¹ Ver lista de materiales estándar		

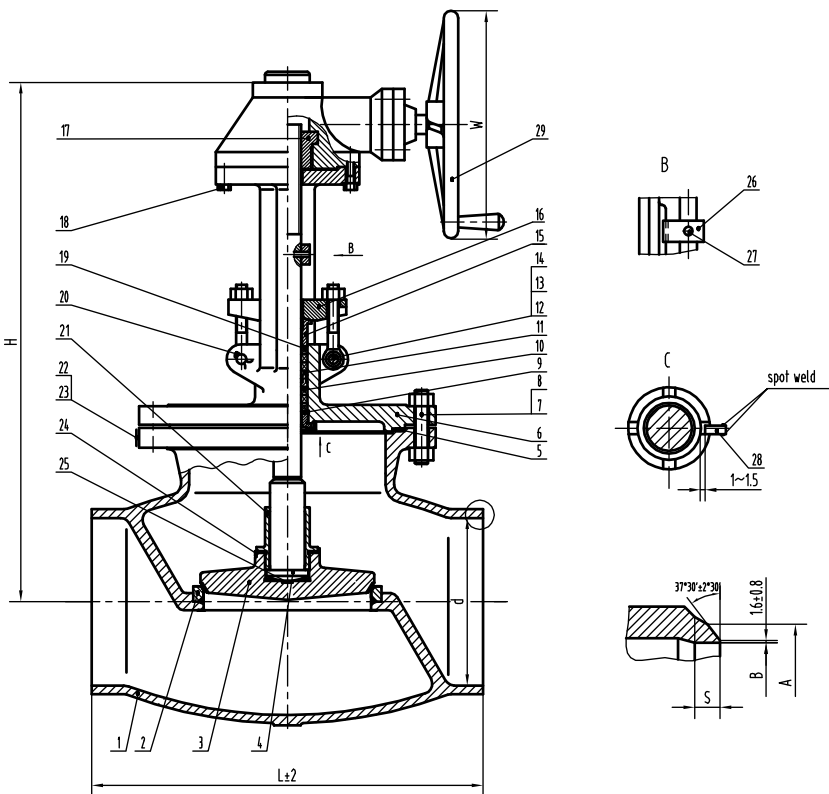

Componentes		
Pos.	Denominación	Material
1	Cuerpo	ASTM A216 WCB
2	Asientos	ASTM A105 +Cr13
3	Obturador	ASTM A105 +Stellite
4	Husillo	ASTM A182 F6a CL3
5	Junta	Acero inox. / Grafito
6	Tapa	ASTM A216 WCB
7	Espárrago	ASTM A193 B7
8	Tuerca	ASTM A194 2H
9	Cierre trasero	ASTM A276 410
10	Empaquetadura	Grafito flexible
11	Linterna	ASTM A276 410
12	Pasador	ASTM A29 1035
13	Tornillo	ASTM A193 B7
14	Tuerca	ASTM A194 2H
15	Prensaestopas	ASTM A276 410
16	Brida prensaestopas	ASTM A216 WCB
17	Tuerca husillo	
18	Tornillo	ASTM A193 B7
19	Empaquetadura	Grafito / Acero inox.
20	Pasador	ASTM A36
21	Tuerca obturador	ASTM A182 F6a CL1
22	Chapa identificación	ASTM A240 321
23	Remache	ASTM A276 321
24	Arandela	ASTM A276 304
25	Pletina empuje	ASTM A276 420
26	Pletina empuje	ASTM A29 1045
27	Pasador	ASTM A29 4140
28	Lengüetas	ASTM A105
29	Reductor manual	

FIG. GL03013XU - GLOBO WCB/F6 XU TRIM N° 8 - 600LBS BW

DN	d	A	SCH 40 (STD)		SCH 60		SCH 80 (XS)		SCH 100		SCH 120	L	W	H	Peso (kg)	
			S	B	S	B	S	B	S	B						
6"	152	172	11	154			17	146.5			22	140	559	458	779	229.8
8"	200	223	13	203	16	198.5	20	193.5	23	189	28	182.5	660	458	954	405.2

VÁLVULAS FUNDIDAS ANSI

GLOBO 600LBS 12" - 20" BRIDAS CON REDUCTOR

Globo		Clase: 600LBS
VÁLVULA GLOBO ACERO CARBONO 600LBS BRIDAS		
Especificaciones		
Material	Acero carbono ASTM A216 WCB ¹	
Diseño	BS 1873	
Conexiones	Bridas según ASME B16.5 RF	
Longitud	ASME B16.10	
Inspección y Pruebas	API 598	
NACE MR 01-75	Bajo demanda	
Aplicaciones	Refinerías, Petroquímica, Química, Metalurgia, Papel, Farmacéuticas...	
¹ Ver lista de materiales estándar		

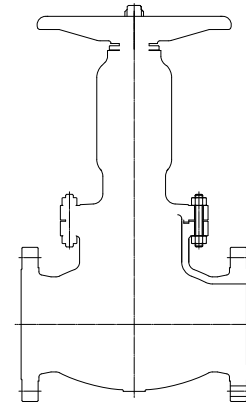

Componentes			
Pos.	Denominación	Cant.	Material
1	Cuerpo	1	ASTM A216 WCB
2	Asientos	1	ASTM A105 +Stellite
3	Disco	1	ASTM A105 +13Cr
4	Tapa disco	1	ASTM A182 F6a
5	Husillo	1	ASTM A276 410
6	Tornillo cuerpo-tapa		ASTM A193 B7
7	Tuerca cuerpo-tapa		ASTM A194 2H
8	Tapa	1	ASTM A216 WCB
9	Pasador	2	ASTM A108 1035
10	Tornillo de ojo	2	ASTM A193 B7
11	Tuerca	2	ASTM A194 2H
12	Brida prensaestopas	1	ASTM A216 WCB
13	Reductor	1	
14	Prensaestopas	1	ASTM A276 410
15	Empaquetadura	2	Grafito
16	Empaquetadura	4-5	Grafito flexible
17	Linterna	1	ASTM A276 410
18	Back seat	1	ASTM A276 410
19	Junta cuerpo-tapa	1	Spirom. 304/Grafito
20	Remache	2	304SS
21	Placa identificación	1	304SS

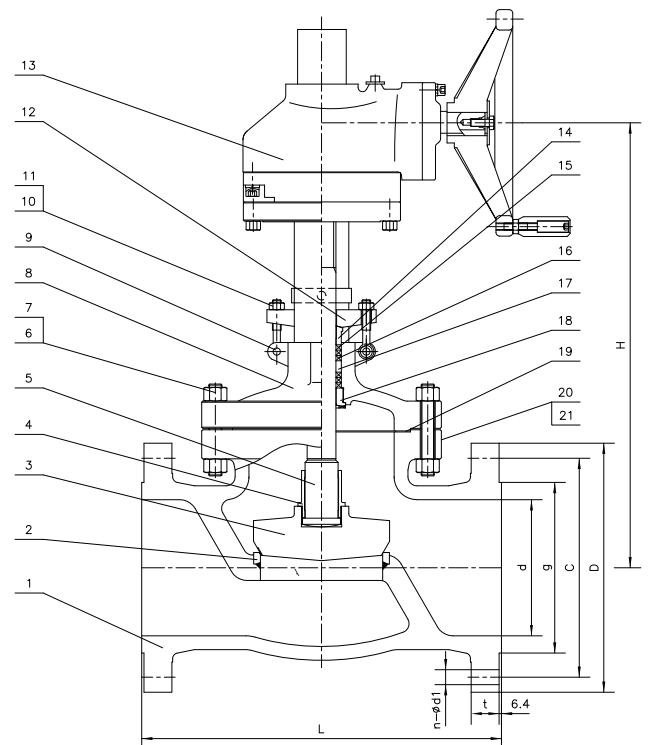

GLOBO WCB/F6 XU TRIM N° 8 - 600LBS RF

Código	DN	d	L	D	C	g	t	n	d1	H	Peso (kg)
-	12"	298	838	559	489	381	67	20	35	1.060	879
-	14"	327	889	603	527	413	70	20	38	1.109	1.421
-	16"	375	991	686	603	470	77	20	41	1.176	2.535
-	18"	419	1.092	743	654	533	83	20	44	1.230	2.963
-	20"	464	1.194	813	724	584	89	24	44	1.293	3.750

GLOBO 900LBS 2" - 4" BRIDAS CON REDUCTOR

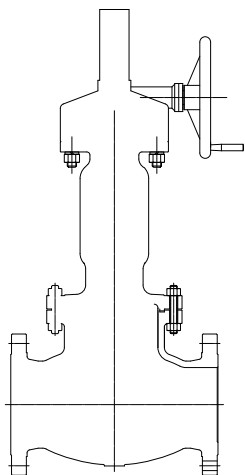

Globo Fig. GL09012XU		Clase: 900LBS
VÁLVULA GLOBO ACERO CARBONO 900LBS BRIDAS		
Especificaciones		
Material	Acero carbono ASTM A216 WCB ¹	
Diseño	BS 1873	
Conexiones	Bridas según ASME B16.5 RF o RTJ	
Longitud	ASME B16.10	
Inspección y Pruebas	API 598	
NACE MR 01-75	Bajo demanda	
Aplicaciones	Refinerías, Petroquímica, Química, Metalurgia, Papel, Farmacéuticas...	
¹ Ver lista de materiales estándar		

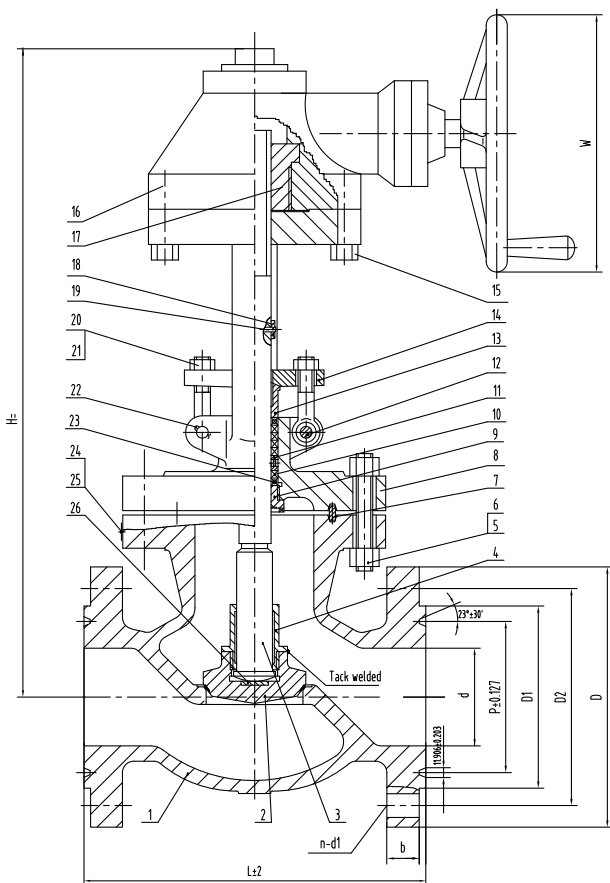

Componentes		
Pos.	Denominación	Material
1	Cuerpo	ASTM A216 WCB
2	Disco	ASTM A105 +Stellite
3	Husillo	ASTM A182 F6a
4	Tapa Disco	ASTM A276 410
5	Espárrago	ASMT A193 B7
6	Tuerca	ASTM A194 2H
7	Arandela	ASTM A240 304
8	Tapa	ASTM A216 WCB
9	Cierre trasero	ASTM A276 410
10	Empaquetadura	Grafito
11	Linterna	ASTM A276 410
12	Pasador	ASTM A29 1035
13	Prensaestopas	ASTM A276 410
14	Brida prensa	ASTM A216 WCB
15	Casquillo	
16	Tuerca husillo	ASTM A439 D-2
17	Engrasador	ASTM A36
18	Tuerca retén	ASTM A29 1035
19	Volante	ASTM A536 60-40-18
20	Tuerca volante	ASTM A36
21	Guía	ASTM A29 1045
22	Pasador	ASTM A276 410
23	Tornillo de ojo	ASTM A193 B7
24	Tuerca	ASTM A194 2H
25	Pasador	ASTM A36
26	Empaquetadura	Grafito/Acero inox.
27	Placa identificación	ASTM A240 321
28	Remache	ASTM A276 321
29	Arandela empuje	ASTM A276 420

FIG. GL09012XU - GLOBO WCB/F6 XU TRIM Nº 8 - 900LBS RF

Código	DN	d	P	D1	D2	D	n-Ø	L	T	W	H		Peso (kg)
											cerrada	abierta	
-	2"	47.5	95.250	124	165	216	8-Ø 25	371	38.1	350	607	620	99.3
010101302721966	3"	73	123.825	155.5	190.5	241	8-Ø 25	384	38.1	400	634	665	112.2
-	4"	98	149.22	181	235	292	8-Ø 32	460	44.5	450	678	813	148

VÁLVULAS FUNDIDAS ANSI

GLOBO 900LBS 6" DISEÑO PRESSURE SEAL CON REDUCTOR

Globo Fig. GL09013XU		Clase: 900LBS
VÁLVULA GLOBO ACERO CARBONO 900LBS SOLDAR		
Especificaciones		
Material	Acero carbono ASTM A216 WCB ¹	
Diseño	BS 1873	
Conexiones	Butt Welding según ASME B16.25	
Longitud	ASME B16.10	
Inspección y Pruebas	API 598	
NACE MR 01-75	Bajo demanda	
Aplicaciones	Refinerías, Petroquímica, Química, Metalurgia, Papel, Farmacéuticas...	
¹ Ver lista de materiales estándar		

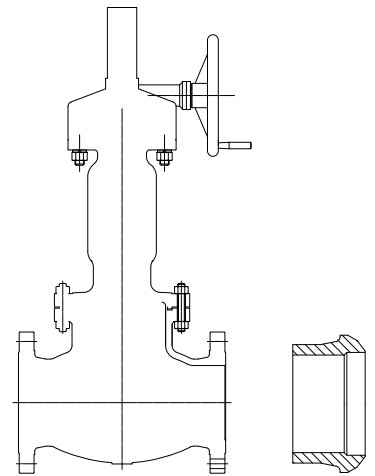

Componentes		
Pos.	Denominación	Material
1	Cuerpo	ASTM A216 WCB
2	Disco	ASTM A105 +Stellite
3	Pletina de empuje	ASTM A276 420
4	Tuerca disco	ASTM A182 F6a CL1
5	Husillo	ASTM A182 F6a CL3
6	Anillo sellado	ASTM A182 F304
7	Caja prensaestopas	ASTM A105
8	Tapa	ASTM A216 WCB
9	Pasador	ASTM A29 1035
10	Anillo	ASTM A276 410
11	Tuerca	ASTM A29 1045
12	Linterna	ASTM A276 410
13	Empaquetadura	Grafito
14	Prensaestopas	ASTM A276 410
15	Brida prensaestopas	ASTM A216 WCB
16	Pasador	ASTM A29 1035
17	Tornillo	ASTM A193 B7
18	Tuerca	ASTM A194 2H
19	Tuerca husillo	
20	Reductor manual	
21	Brida	ASTM A105
22	Tornillo	ASTM A193 B7
23	Bloque	ASTM A276 410
24	Pasador	ASTM A29 1035
25	Empaquetadura	Acero inox. / Grafito
26	Placa identificación	ASTM A240 321
27	Remache	ASTM A276 321

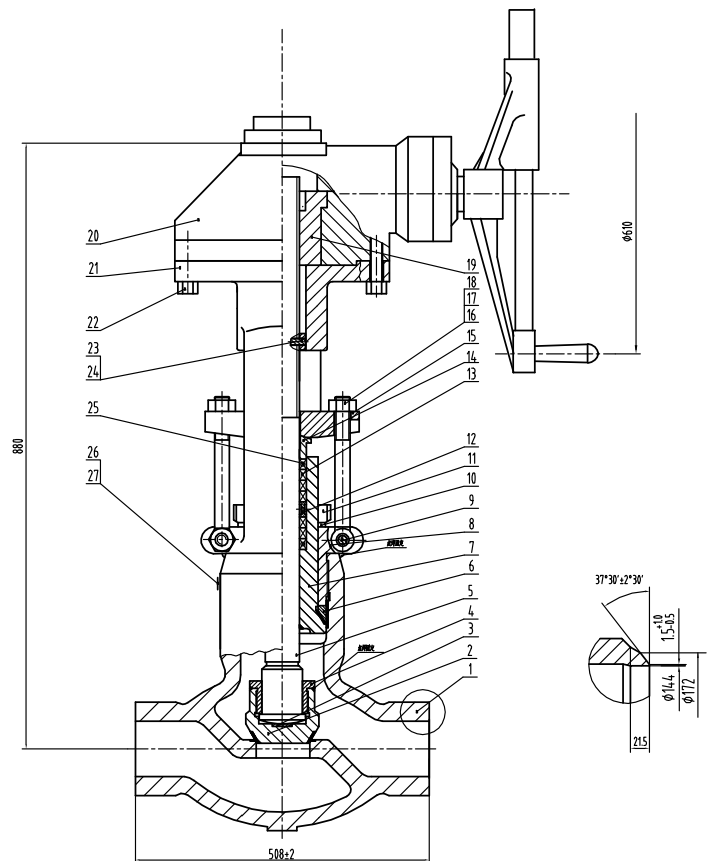

GLOBO 900LBS 8" DISEÑO PRESSURE SEAL CON REDUCTOR

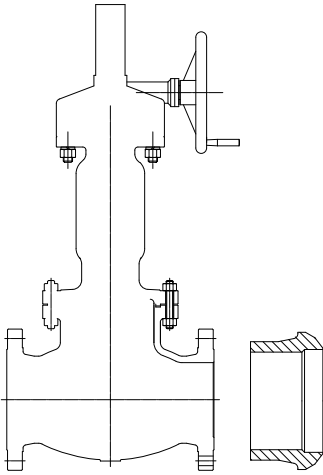

Globo Fig. GL09013XU		Clase: 900LBS
VÁLVULA GLOBO ACERO CARBONO 900LBS SOLDAR		
Especificaciones		
Material	Acero carbono ASTM A216 WCB ¹	
Diseño	BS 1873	
Conexiones	Butt Welding según ASME B16.25	
Longitud	ASME B16.10	
Inspección y Pruebas	API 598	
NACE MR 01-75	Bajo demanda	
Aplicaciones	Refinerías, Petroquímica, Química, Metalurgia, Papel, Farmacéuticas...	
¹ Ver lista de materiales estándar		

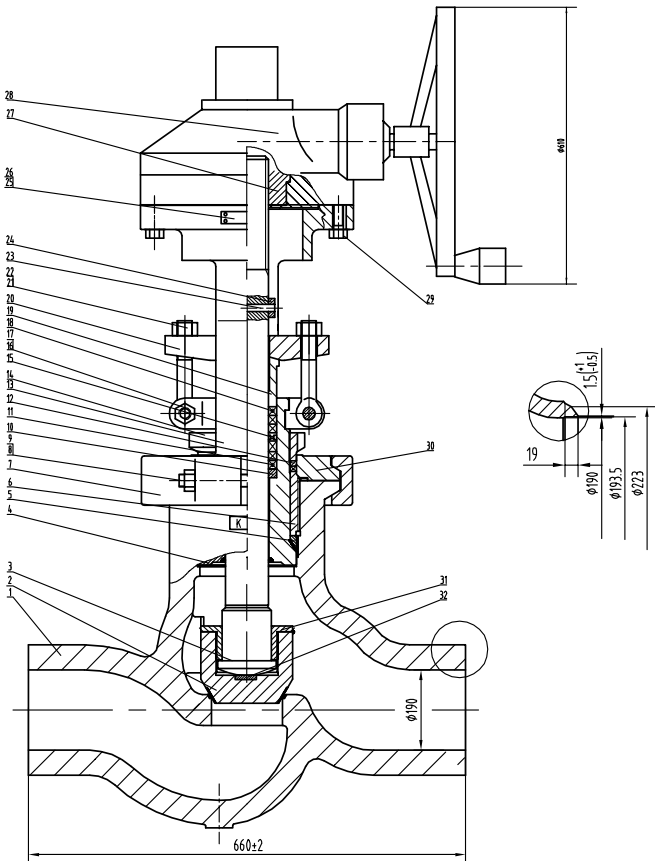

Componentes		
Pos.	Denominación	Material
1	Cuerpo	ASTM A216 WCB
2	Disco	ASTM A105 +Stellite
3	Husillo	ASTM A182 F6a CL3
4	Caja prensaestopas	ASTM A105
5	Anillo sellado	ASTM A182 F304
6	Tuerca	ASTM A29 1025
7	Anillo cuerpo	ASTM A216 WCB
8	Espárrago	ASTM A193 B7
9	Tuerca	ASTM A194 2H
10	Espaciador empaquetadura	ASTM A276 410
11	Empaquetadura	Acero inox. / Grafito
12	Anillo	ASTM A276 410
13	Puente	ASTM A216 WCB
14	Tuerca	ASTM A29 1045
15	Linterna	ASTM A276 410
16	Tornillo	ASTM A193 B7
17	Tuerca	ASTM A194 2H
18	Empaquetadura	Grafito
19	Prensaestopas	ASTM A276 410
20	Brida prensaestopas	ASTM A29 1045
21	Tornillo	ASTM A193 B7
22	Tuerca	ASTM A194 2H
23	Pasador	ASTM A29 4140
24	Bloque guía	ASTM A29 1025
25	Placa identificación	ASTM A240 321
26	Remache	ASTM A276 321
27	Tuerca husillo	
28	Reductor manual	
29	Tornillo	ASTM A193 B7
30	Empaquetadura	ASTM A29 1045
31	Tuerca disco	ASTM A182 F6a CL1
32	Pletina de empuje	ASTM A276 420

VÁLVULAS FUNDIDAS ANSI

GLOBO 900LBS 10" - 20" DISEÑO PRESSURE SEAL

Globo		Clase: 900LBS
VÁLVULA GLOBO ACERO CARBONO 1500LBS SOLDAR		
Especificaciones		
Material	Acero carbono ASTM A216 WCB ¹	
Diseño	BS 1873	
Conexiones	Butt Welding según ASME B16.25	
Longitud	ASME B16.10	
Inspección y Pruebas	API 598	
NACE MR 01-75	Bajo demanda	
Aplicaciones	Refinerías, Petroquímica, Química, Metalurgia, Papel, Farmacéuticas...	
¹ Ver lista de materiales estándar		

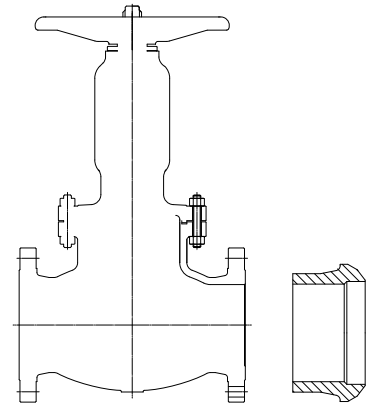

Componentes		
Pos.	Denominación	Material
1	Cuerpo	ASTM A216 WCB +13% Cr
2	Asientos	ASTM A105 +Stellite 6
3	Disco	ASTM A182 F6a +Stellite 6
4	Tuerca Disco	A276 410
5	Husillo	A182 F6a
6	Tapa	A105 +13% Cr
7	Anillo Sellado	A182 F304L
8	Anillo espaciador	ANSI 1045
9	Anillo empuje partido	ANSI 1045
10	Retén tapa	ANSI 1045
11	Tuerca	A194 2H
12	Tornillo	A193 B7
13	Tuerca	A194 2H
14	Tornillo	A193 B7
15	Tuerca	A194 2H
16	Tornillo	A193 B7
17	Brida prensaestopas	A216 WCB
18	Tuerca	A194 2H
19	Tornillo ojo	A193 B7
20	Tuerca volante	Acero carbono
21	Arandela	Acero carbono
22	Volante	A536 60-40-18
23	Tornillo	Acero carbono
24	Tuerca husillo	A439 D-2
25	Prensaestopas	A276 410
26	Retén	A216 WCB
27	Empaquetadura	Grafito flexible
28	Anillo linterna	A276 410
29	Empaquetadura	Grafito trenzado

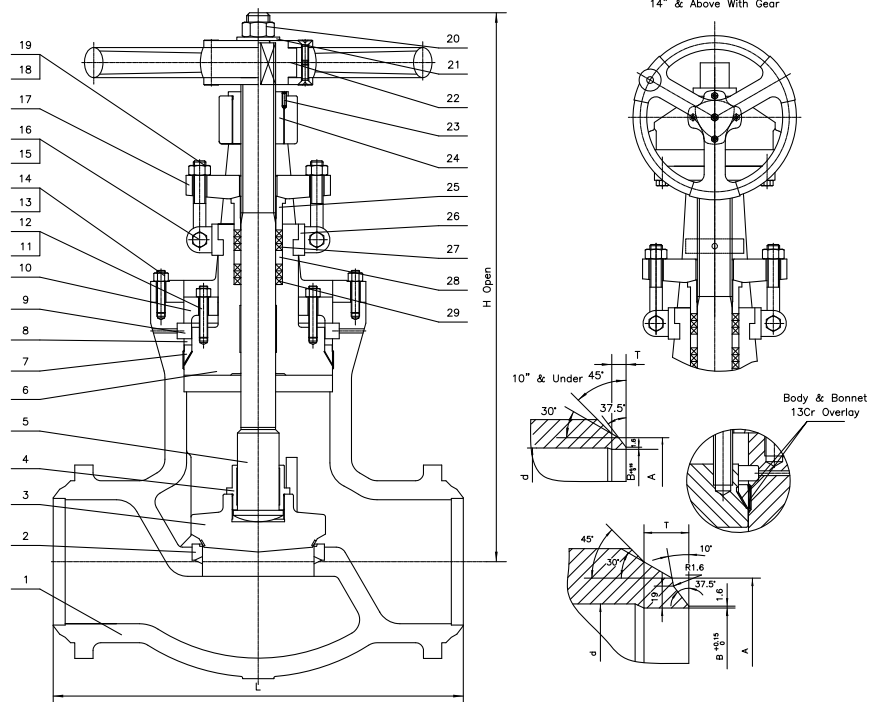

GLOBO WCB/F6 XU TRIM N° 8 - 900LBS BW

Código	DN	SCH	d	L	A	B	t	H
-	10"	120	238	787	278	230	35	1130
-	12"	120	282	914	329	273	40	1290
-	14"	120	311	991	362	300	45	1450
-	16"	120	356	1092	413	344	50	1602
-	18"	120	400	1181	464	387	55	1757
-	20"	120	445	1283	516	432	60	1909

GLOBO 1500LBS 3" DISEÑO PRESSURE SEAL

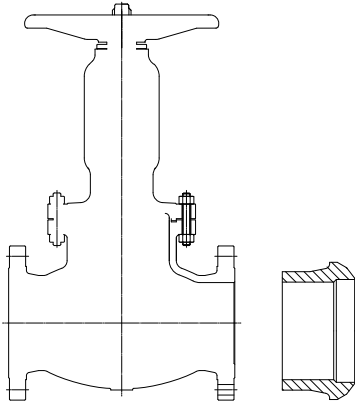

Globo Fig. GL15013XU		Clase: 1500LBS
VÁLVULA GLOBO ACERO CARBONO 1500LBS SOLDAR		
Especificaciones		
Material	Acero carbono ASTM A216 WCB ¹	
Diseño	BS 1873	
Conexiones	Butt Welding según ASME B16.25	
Longitud	ASME B16.10	
Inspección y Pruebas	API 598	
NACE MR 01-75	Bajo demanda	
Aplicaciones	Refinerías, Petroquímica, Química, Metalurgia, Papel, Farmacéuticas...	
¹ Ver lista de materiales estándar		

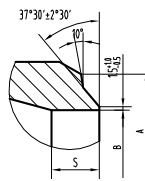
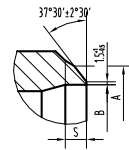
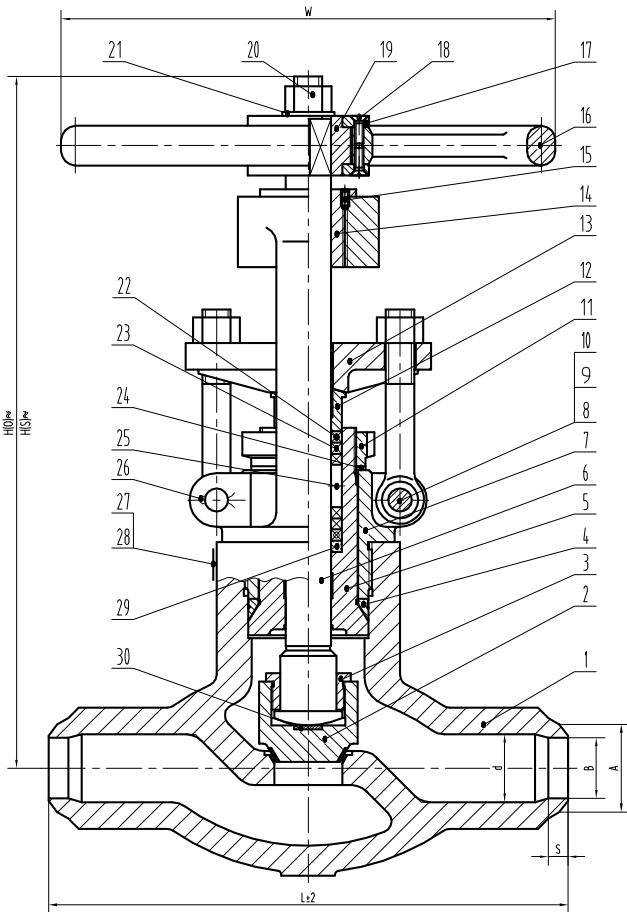

Componentes		
Pos.	Denominación	Material
1	Cuerpo	ASTM A216 WCB
2	Disco	ASTM A105 +Stellite
3	Tuerca disco	ASTM A182 F6a CL1
4	Anillo sellado	ASTM A182 F304
5	Caja prensaestopas	ASTM A105
6	Husillo	ASTM A182 F6a CL3
7	Puente	ASTM A216 WCB
8	Pasador	ASTM A29 1035
9	Tornillo	ASTM A193 B7
10	Tuerca	ASTM A194 2H
11	Tuerca	ASTM A29 1045
12	Prensaestopas	ASTM A276 410
13	Brida prensaestopas	ASTM A216 WCB
14	Tuerca husillo	ASTM A439 D-2
15	Tornillo	ASTM A29 1035
16	Volante de impacto	ASTM A216 WCB
17	Protección volante	ASTM A36
18	Tornillo	ASTM A29 1035
19	Casquillo de impacto	ASTM A29 1045
20	Arandela	ASTM A36
21	Tuerca retén	ASTM A36
22	Empaquetadura	Acero inox. / Grafito
23	Empaquetadura	Grafito
24	Arandela	ASTM A36
25	Linterna	ASTM A276 410
26	Pasador	ASTM A36
27	Placa identificación	ASTM A240 321
28	Remache	ASTM A276 321
29	Arandela empaquetadura	ASTM A276 410
30	Pletina de empuje	ASTM A276 420

FIG. GL15013XU - GLOBO WCB/F6 XU TRIM N° 8 - 1500LBS BW

Código	DN	d	A	SCH 80		SCH 100		SCH 120		SCH 140		SCH 160		SCH XXS		a	L	H1	H2	Peso (kg)
				B	S	B	S	B	S	B	S	B	S	B	S					
-	3"	70	91	73.5	12							66.5	17	58.5	23	23.8	470	622	705	172

VÁLVULAS FUNDIDAS ANSI

GLOBO 1500LBS 4" - 6" DISEÑO PRESSURE SEAL CON REDUCTOR

Globo Fig. GL15013XU		Clase: 1500LBS
VÁLVULA GLOBO ACERO CARBONO 1500LBS BRIDAS		
Especificaciones		
Material	Acero carbono ASTM A216 WCB ¹	
Diseño	BS 1873	
Conexiones	Bridas según ASME B16.5 RF	
Longitud	ASME B16.10	
Inspección y Pruebas	API 598	
NACE MR 01-75	Bajo demanda	
Aplicaciones	Refinerías, Petroquímica, Química, Metalurgia, Papel, Farmacéuticas...	
¹ Ver lista de materiales estándar		

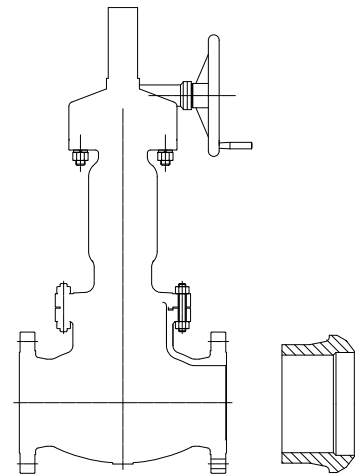

Componentes		
Pos.	Denominación	Material
1	Cuerpo	ASTM A216 WCB + CR13
2	Disco	ASTM A105 +Stellite
3	Pletina de empuje	ASTM A276 +420
4	Tuerca disco	ASTM A182 F6a CL1
5	Husillo	ASTM A182 F6a CL3
6	Anillo de sellado	ASTM A182 F304
7	Caja prensaestopas	ASTM 105
8	Tapa	ASTM A216 WCB
9	Pasador	ASTM A29 1035
10	Anillo	ASTM A276 410
11	Tuerca	ASTM A29 1045
12	Linterna	ASTM A276 410
13	Empaquetadura	Grafito
14	Prensaestopas	ASTM A276 410
15	Brida prensaestopas	ASTM A216 WCB
16	Pasador	ASTM A29 1035
17	Tornillo	ASTM A193 B7
18	Tuerca	ASTM A194 2H
19	Tuerca husillo	
20	Reductor manual	
21	Brida	ASTM A105
22	Tornillo	ASTM A193 B7
23	Bloque	ASTM A276 410
24	Pasador	ASTM A29 1035
25	Empaquetadura	Acero inox. / Grafito
26	Placa identificación	ASTM A240 321
27	Remache	ASTM A276 321

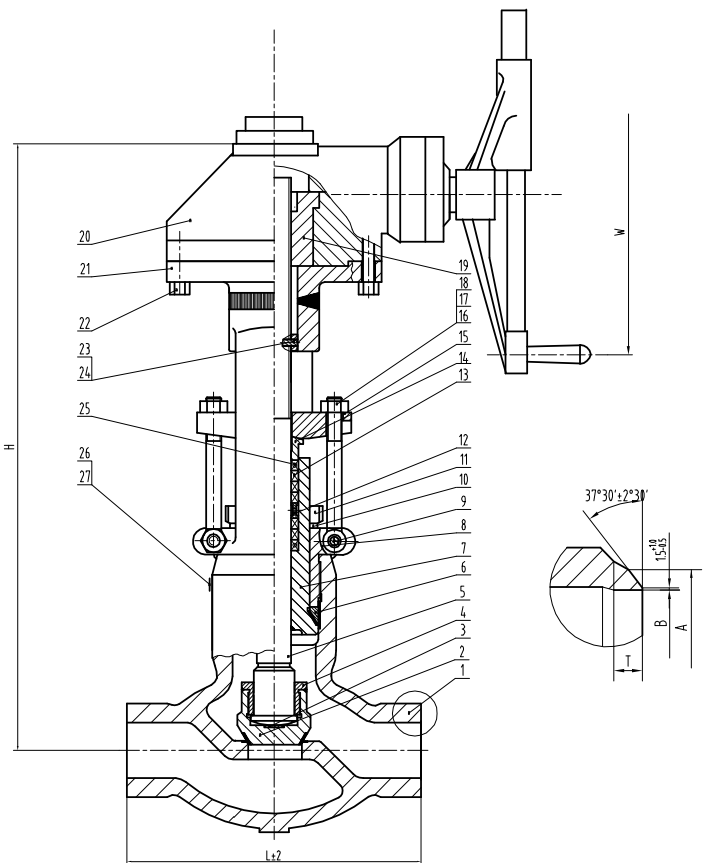
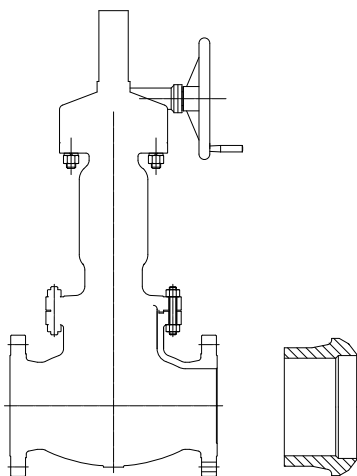

FIG. GL15013XU - GLOBO WCB/F6 XU TRIM N° 8 - 1500LBS BW

Código	DN	d	L	H	A	SCH 80		SCH 100		SCH 120		SCH 140		SCH 160		SCH XXS		W
						B	T	B	T	B	T	B	T	B	T			
-	4"	92	406	800	117	97	13			92	17			87.5	21	80	26	610
-	6"	137	559	830	172	146.5	17			140	22			132	28	124.5	33	610

GLOBO 1500LBS 8" DISEÑO PRESSURE SEAL CON REDUCTOR



Globo Fig. GL15013XU		Clase: 1500LBS
VÁLVULA GLOBO ACERO CARBONO 1500LBS SOLDAR		
Especificaciones		
Material	Acero carbono ASTM A216 WCB ¹	
Diseño	BS 1873	
Conexiones	Butt Welding según ASME B16.25	
Longitud	ASME B16.10	
Inspección y Pruebas	API 598	
NACE MR 01-75	Bajo demanda	
Aplicaciones	Refinerías, Petroquímica, Química, Metalurgia, Papel, Farmacéuticas...	
¹ Ver lista de materiales estándar		

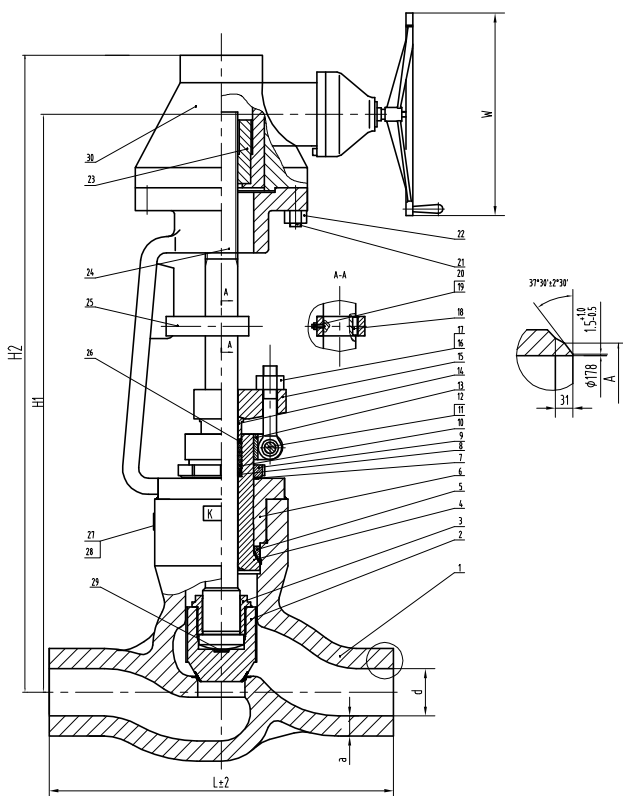

Componentes		
Pos.	Denominación	Material
1	Cuerpo	ASTM A216 WCB
2	Disco	ASTM A105 +Stellite
3	Tuerca disco	ASTM A182 F6a CL1
4	Caja prensaestopas	ASTM A105
5	Anillo de sellado	ASTM A182 F304
6	Puente	ASTM A216 WCB
7	Anillo	ASTM A36
8	Espaciador empaquetadura	ASTM A276 410
9	Tuerca retén	ASTM A29 1045
10	Empaquetadura	Grafito
11	Pasador	ASTM A29 1035
12	Pasador	ASTM A36
13	Anillo conector	ASTM A216 WCB
14	Prensaestopas	ASTM A276 410
15	Brida prensaestopas	ASTM A29 1045
16	Tornillo	ASTM A193 B7
17	Tuerca	ASTM A194 2H
18	Chaveta	ASTM A29 1045
19	Tornillo	ASTM A29 1035
20	Tuerca	ASTM A29 1035
21	Espárrago	ASTM A193 B7
22	Tuerca	ASTM A194 2H
23	Tuerca husillo	
24	Husillo	ASTM A182 F6a CL3
25	Pletina guía	ASTM A29 1045
26	Empaquetadura	Acero inox. / Grafito
27	Placa identificación	ASTM A240 321
28	Remache	ASTM A276 321
29	Pletina de empuje	ASTM A276 420
30	Reductor manual	

FIG. GL15013XU - GLOBO WCB/F6 XU TRIM N° 8 - 1500LBS BW

Código	DN	d	A	SCH 140	L	W	a	H1	H2	Peso (kg)	
				B	S						
-	8"	178	223	178	31	832	810	48	1244	1382	569

VÁLVULAS FUNDIDAS ANSI

GLOBO 1500LBS RTJ 4" - 8" DISEÑO PRESSURE SEAL CON REDUCTOR

Globo Fig. GL15012XU		Clase: 1500LBS
VÁLVULA GLOBO ACERO CARBONO 1500LBS BRIDAS		
Especificaciones		
Material	Acero carbono ASTM A216 WCB ¹	
Diseño	BS 1873	
Conexiones	Bridas según ASME B16.5 RTJ	
Longitud	ASME B16.10	
Inspección y Pruebas	API 598	
NACE MR 01-75	Bajo demanda	
Aplicaciones	Refinerías, Petroquímica, Química, Metalurgia, Papel, Farmacéuticas...	
¹ Ver lista de materiales estándar		

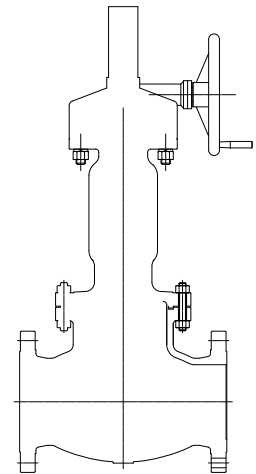

Componentes		
Pos.	Denominación	Material
1	Cuerpo	ASTM A216 WCB
2	Disco	ASTM A105 +Stellite
3	Husillo	ASTM A182 F6a CL3
4	Protección disco	ASTM A276 410
5	Caja prensaestopas	ASTM A105
6	Anillo de sellado	ASTM A276 304
7	Tuerca	ASTM A276 410
8	Tornillo	ASTM A276 410
9	Placa identificación	ASTM A240 321
10	Remache	ASTM A276 321
11	Arandela	ASTM A36
12	Espárrago	ASTM A193 B7
13	Tuerca	ASTM A194 2H
14	Empaquetadura	Grafito
15	Tornillo	ASTM A193 B7
16	Arandela	ASTM A36
17	Tuerca	ASTM A194 2H
18	Anillo	ASTM A216 WCB
19	Tornillo	ASTM A193 B7
20	Tuerca	ASTM A194 2H
21	Prensaestopas	ASTM A276 410
22	Brida prensaestopas	ASTM A29 1045
23	Puente	ASTM A216 WCB
24	Pletina guía	ASTM A105
25	Tornillo	ASTM A29 1035
26	Tuerca	ASTM A194 2H
27	Chaveta	ASTM A29 1045
28		
29	Tuerca husillo	
30	Tornillo	ASTM A193 B7
31	Tuerca	ASTM A194 2H
32	Empaquetadura	Acero inox. / Grafito
33	Anillo segmentado	ASTM A276 410
34	Linterna	ASTM A276 410
35	Anillo empaquetadura	ASTM A276 410
36	Tuerca	ASTM A29 1035
37	Pletina de empuje	ASTM A240 420

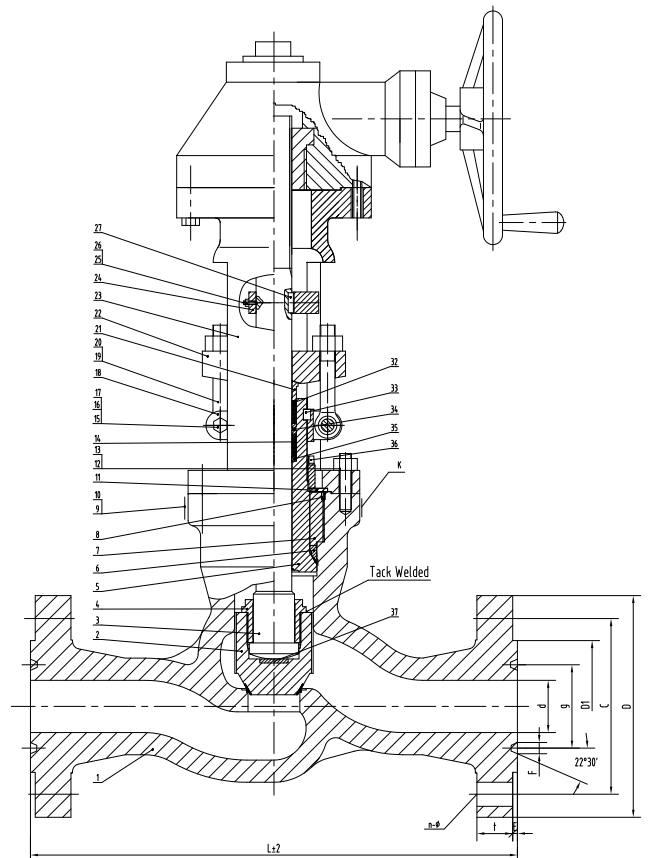
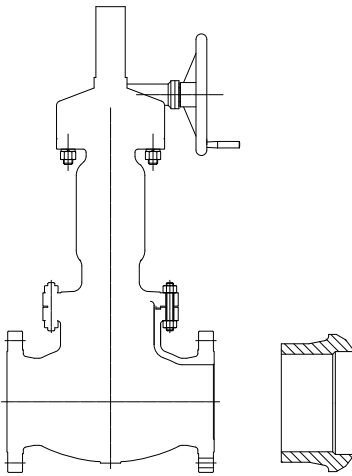

FIG. GL15012XU - GLOBO WCB/F6 XU TRIM N° 8 - 1500LBS RTJ

Código	DN	d	g	D1	C	D	t	L	n-Ø	F	E
-	4"	73	157.18	203	273	355	76.2	683	8-42	16.66	11.13
-	6"	111	228.6	279	368.5	485	108	927	8-54	19.84	12.70
-	8"	146	279.4	340	438.2	550	127	1038	12-54	23.01	14.27

GLOBO 1500LBS 10" - 20" DISEÑO PRESSURE SEAL



Globo		Clase: 1500LBS
VÁLVULA GLOBO ACERO CARBONO 1500LBS SOLDAR		
Especificaciones		
Material	Acero carbono ASTM A216 WCB ¹	
Diseño	BS 1873	
Conexiones	Butt Welding según ASME B16.25	
Longitud	ASME B16.10	
Inspección y Pruebas	API 598	
NACE MR 01-75	Bajo demanda	
Aplicaciones	Refinerías, Petroquímica, Química, Metalurgia, Papel, Farmacéuticas...	
¹ Ver lista de materiales estándar		

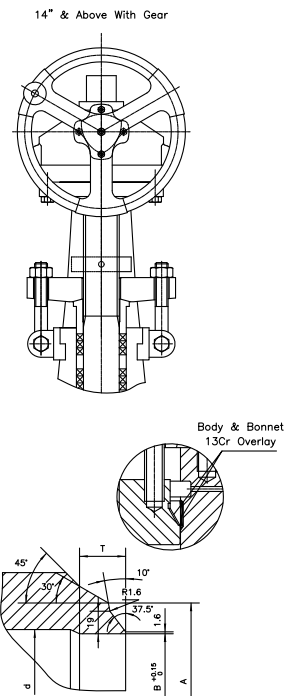
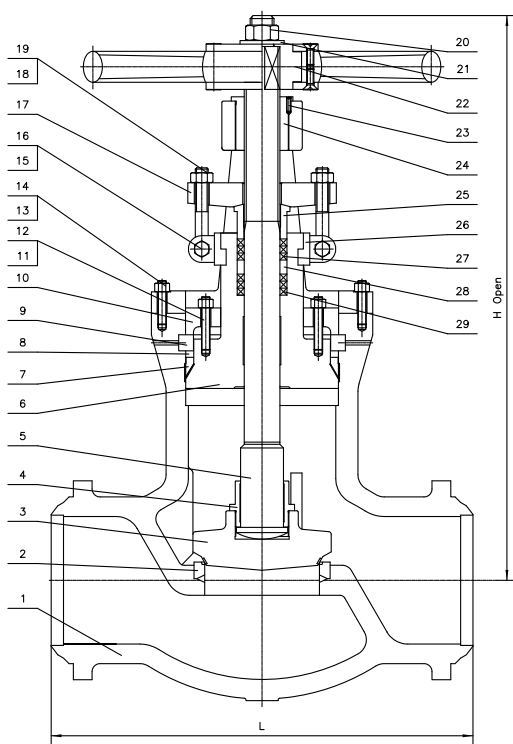

Componentes		
Pos.	Denominación	Material
1	Cuerpo	ASTM A216 WCB +13% Cr
2	Asiento	A105 +Stellite 6
3	Disco	A216 WCB +Stellite 6
4	Tuerca Disco	A276 410
5	Husillo	A182 F6a
6	Tapa	A105 +13% Cr
7	Anillo Sellado	A182 F304L
8	Anillo espaciador	ANSI 1045
9	Anillo empuje partido	ANSI 1045
10	Retén tapa	ANSI 1045
11	Tuerca	A194 2H
12	Tornillo	A193 B7
13	Tuerca	A194 2H
14	Tornillo	A193 B7
15	Tuerca	A194 2H
16	Tornillo	A193 B7
17	Brida prensaestopas	A216 WCB
18	Tuerca	A194 2H
19	Tornillo ojo	A193 B7
20	Tuerca volante	Acero carbono
21	Arandela	Acero carbono
22	Volante	A536 60-40-18
23	Tornillo	Acero carbono
24	Tuerca husillo	A439 D-2
25	Prensaestopas	A276 410
26	Retén	A216 WCB
27	Empaquetadura	Grafito flexible
28	Anillo linterna	A276 410
29	Empaquetadura	Grafito trenzado

GLOBO WCB/F6 XU TRIM N° 8 - 1500LBS BW

Código	DN	SCH	d	L	A	B	t	H
-	10"	160	222	864	278	216	45	1182
-	12"	160	263	991	329	257	50	13241
-	14"	160	289	1067	362	284	55	1500
-	16"	160	330	1194	413	325	60	1654
-	18"	160	371	1346	464	367	70	1808
-	20"	160	416	1473	516	408	75	1960

VÁLVULAS FUNDIDAS ANSI

GLOBO 2500LBS 2"-5" DISEÑO PRESSURE SEAL

Globo Fig. GL25013XU		Clase: 2500LBS
VÁLVULA GLOBO ACERO ALEADO 2500LBS SOLDAR		
Especificaciones		
Material	Acero aleado ASTM A217 WC9 ¹	
Diseño	BS 1873	
Conexiones	Butt Welding según EN 12627	
Longitud	ASME B16.10	
Inspección y Pruebas	API 598	
NACE MR 01-75	Bajo demanda	
Aplicaciones	Refinerías, Petroquímica, Química, Metalurgia, Papel, Farmacéuticas...	
¹ Ver lista de materiales estándar		

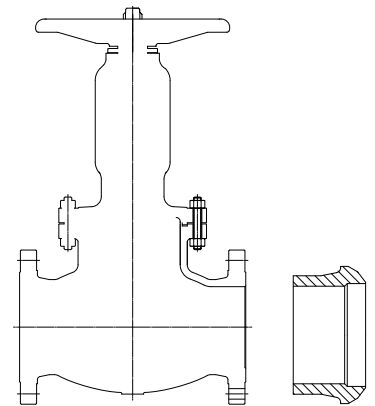

Componentes		
Pos.	Denominación	Material
1	Cuerpo	ASTM A217 WC9
2	Disco	ASTM A182 F22 CL3 +Stellite
3	Tuerca disco	ASTM A182 F6a CL1
4	Husillo	ASTM A182 F6a CL3
5	Caja prensaestopas	ASTM A182 F22 CL3
6	Asiento	ASTM A182 F304
7	Puente	ASTM A217 WC9
8	Espaciador empaquetadura	Acero inox.
9	Empaquetadura	Acero inox. / Grafito
10	Empaquetadura	Grafito
11	Anillo	Acero inox.
12	Linterna	ASTM A276 410
13	Tuerca retén	Acero inox.
14	Tornillo	ASTM A193 B7
15	Tuerca	ASTM A194 2H
16	Anillo	Acero carbono
17	Anillo	Acero inox.
18	Prensaestopas	ASTM A276 410
19	Brida prensaestopas	ASTM A29 1045
20	Tornillo	ASTM A193 B7
21	Tuerca	ASTM A194 2H
22	Tuerca husillo	ASTM A439 D-2
23	Tornillo	Acero carbono
24	Casquillo de impacto	Acero carbono
25	Protector volante	Acero carbono
26	Tuerca	Acero carbono
27	Anillo	Acero carbono
28	Tornillo	Acero carbono
29	Volante	Acero carbono
30	Placa identificación	Acero inox.
31	Remache	Acero inox.
32	Pletina de empuje	Acero inox.

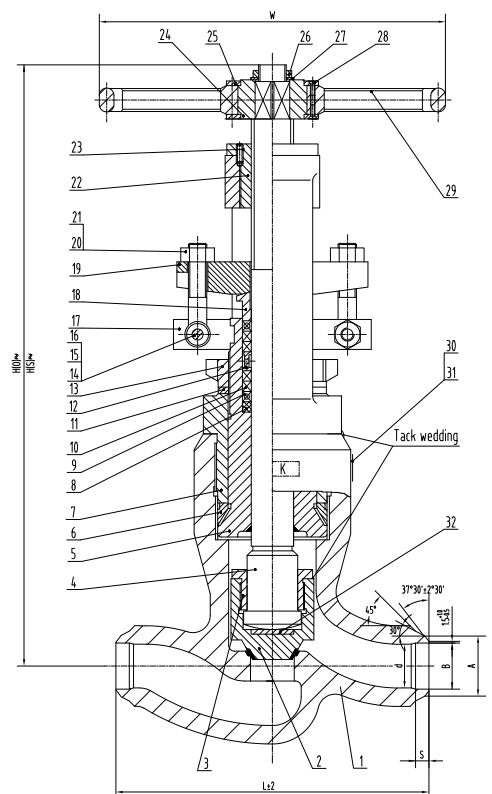
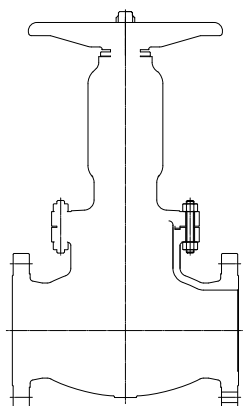

FIG. GL25013XU - GLOBO WC9/F6 XU TRIM N° 8 - 2500LBS BW

Código	DN	d	B	A	S	L	H(s)	H(o)	W	Peso (kg)
-	2"	38.5				279	741	740	450	125.7
-	3"	57.0				368			450	145.6
-	4"	73.0				457				185.7
-	5"	92.0				533				220.0

GLOBO 2500LBS RTJ 2" - 3" DISEÑO PRESSURE SEAL



Globo Fig. GL25013XU		Clase: 2500LBS
VÁLVULA GLOBO ACERO CARBONO 2 500LBS BRIDAS		
Especificaciones		
Material	Acero carbono ASTM A216 WCB ¹	
Diseño	BS 1873	
Conexiones	Bridas según ASME B16.5 RTJ	
Longitud	ASME B16.10	
Inspección y Pruebas	API 598	
NACE MR 01-75	Bajo demanda	
Aplicaciones	Refinerías, Petroquímica, Química, Metalurgia, Papel, Farmacéuticas...	
¹ Ver lista de materiales estándar		

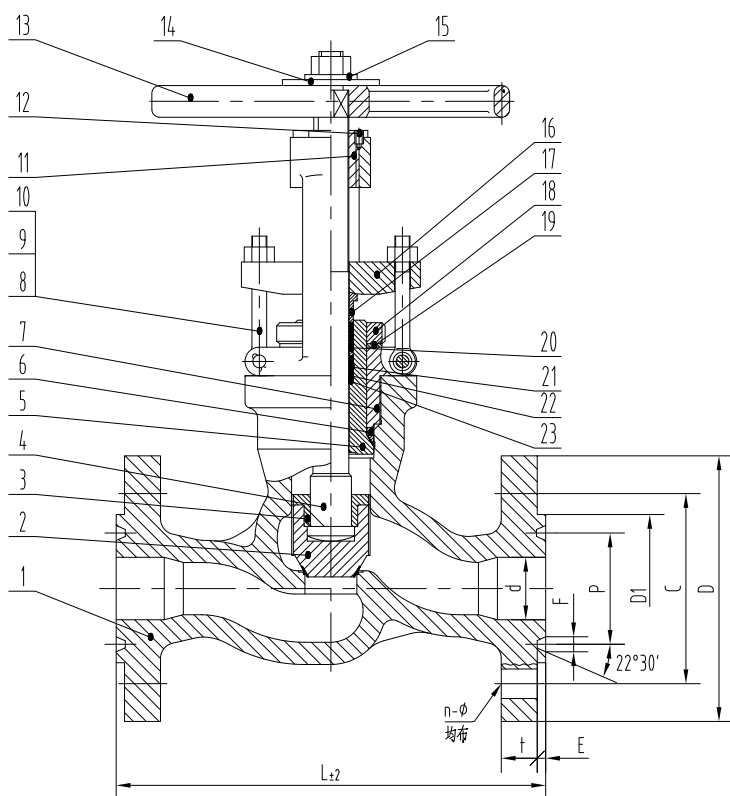

Componentes		
Pos.	Denominación	Material
1	Cuerpo	ASTM A216 WCB + Cr 13
2	Disco	ASTM A105 +Cr 13
3	Tuerca disco	ASTM A276 410
4	Husillo	ASTM A182 F6a CL3
5	Caja prensaestopas	ASTM A105
6	Anillo sellado	ASTM A182 F304
7	Puente	ASTM A216 WCB
8	Pasador	ASTM A29 1035
9	Tornillo	ASTM A29 4135
10	Tuerca	ASTM A29 1045
11	Tuerca husillo	ASTM A439 D-2
12	Tornillo	Acero carbono
13	Volante	ASTM A216 WCB
14	Placa identificación	Acero inox.
15	Arandela	Acero carbono
16	Brida prensaestopas	ASTM A216 WCB
17	Prensaestopas	ASTM A276 410
18	Tuerca	ASTM A29 1045
19	Arandela	Acero carbono
20	Linterna	ASTM A276 410
21	Empaquetadura	Grafito
22	Empaquetadura	Acero inox. / Grafito
23	Espaciador empaquetadura	Acero carbono

FIG. GL25013XU - GLOBO WCB/F6 XU TRIM N° 8 - 2500LBS RTJ

Código	DN	d	P	D1	C	D	E	F	n-Ø	t	L
-	2"	38	101.6	133	171.4	235	7.92	11.91	8-29	51	454
-	3"	58	127	168	228.6	305	9.53	13.5	8-35	67	578

VÁLVULAS FUNDIDAS ANSI

GLOBO 2500LBS 6" - 12" DISEÑO PRESSURE SEAL CON REDUCTOR

Globo		Clase: 2500LBS
VÁLVULA GLOBO ACERO ALEADO 2500LBS SOLDAR		
Especificaciones		
Material	Acero aleado ASTM A217 WCB ¹	
Diseño	BS 1873	
Conexiones	Butt Welding según ANSI B16.25	
Longitud	ANSI B16.10	
Inspección y Pruebas	API 598	
NACE MR 01-75	Bajo demanda	
Aplicaciones	Refinerías, Petroquímica, Química, Metalurgia, Papel, Farmacéuticas...	
¹ Ver lista de materiales estándar		

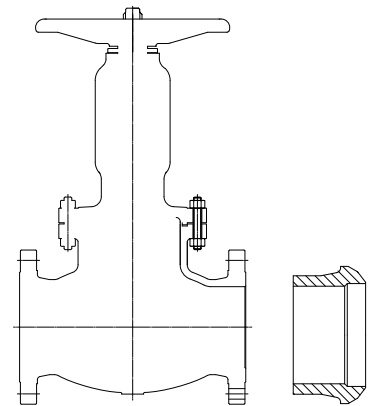

Componentes		
Pos.	Denominación	Material
1	Cuerpo	ASTM A216 WCB +13% Cr
2	Asientos	A105 +Stellite 6
3	Disco	A216 WCB +Stellite 6
4	Tuerca Disco	A276 410
5	Husillo	A182 F6a
6	Tapa	A105 +13% Cr
7	Anillo Sellado	A182 F304L
8	Anillo espaciador	ANSI 1045
9	Anillo empuje partido	ANSI 1045
10	Retén tapa	ANSI 1045
11	Tuerca	A194 2H
12	Tornillo	A193 B7
13	Tuerca	A194 2H
14	Tornillo	A193 B7
15	Tuerca	A194 2H
16	Tornillo	A193 B7
17	Brida prensaestopas	A216 WCB
18	Tuerca	AS194 2H
19	Tornillo ojo	A193 B7
20	Tuerca volante	Acero carbono
21	Arandela	Acero carbono
22	Volante	A536 60-40-18
23	Tornillo	Acero carbono
24	Tuerca husillo	A439 D-2
25	Prensaestopas	A276 410
26	Retén tornillo ojo	A216 WCB
27	Empaquetadura	Grafito flexible
28	Anillo linterna	A276 410
29	Empaquetadura	Grafito trenzado

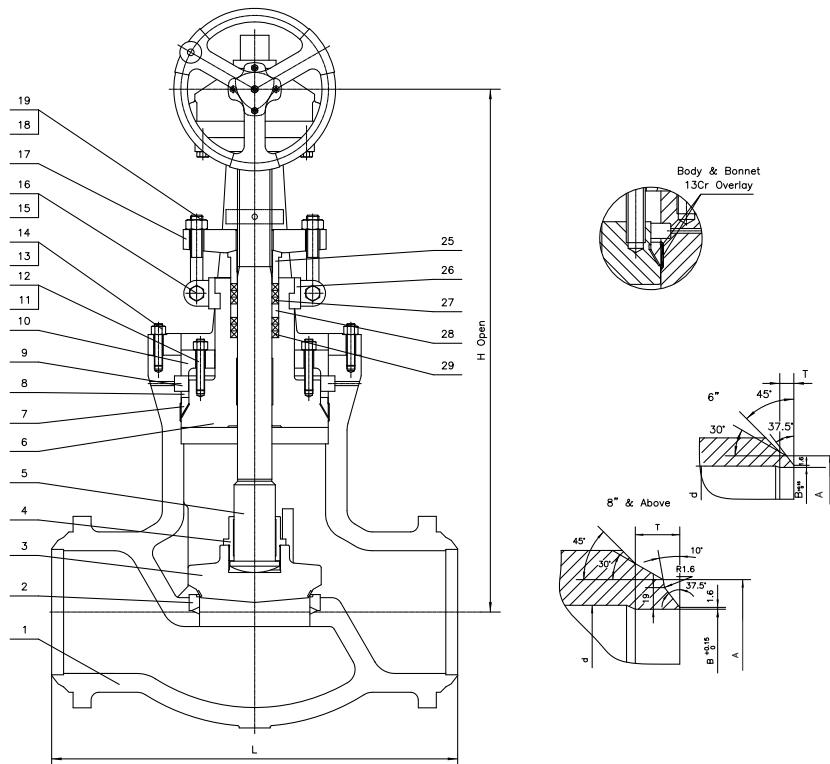

GLOBO WCB/F6 XU TRIM N° 8 - 2500LBS BW

Código	DN	SCH	d	L	A	B	t	H
-	6"	160	111	610	172	132	28	837
-	8"	160	146	762	223	173	35	991
-	10"	160	184	914	278	216	45	1267
-	12"	160	219	1041	329	257	50	1598

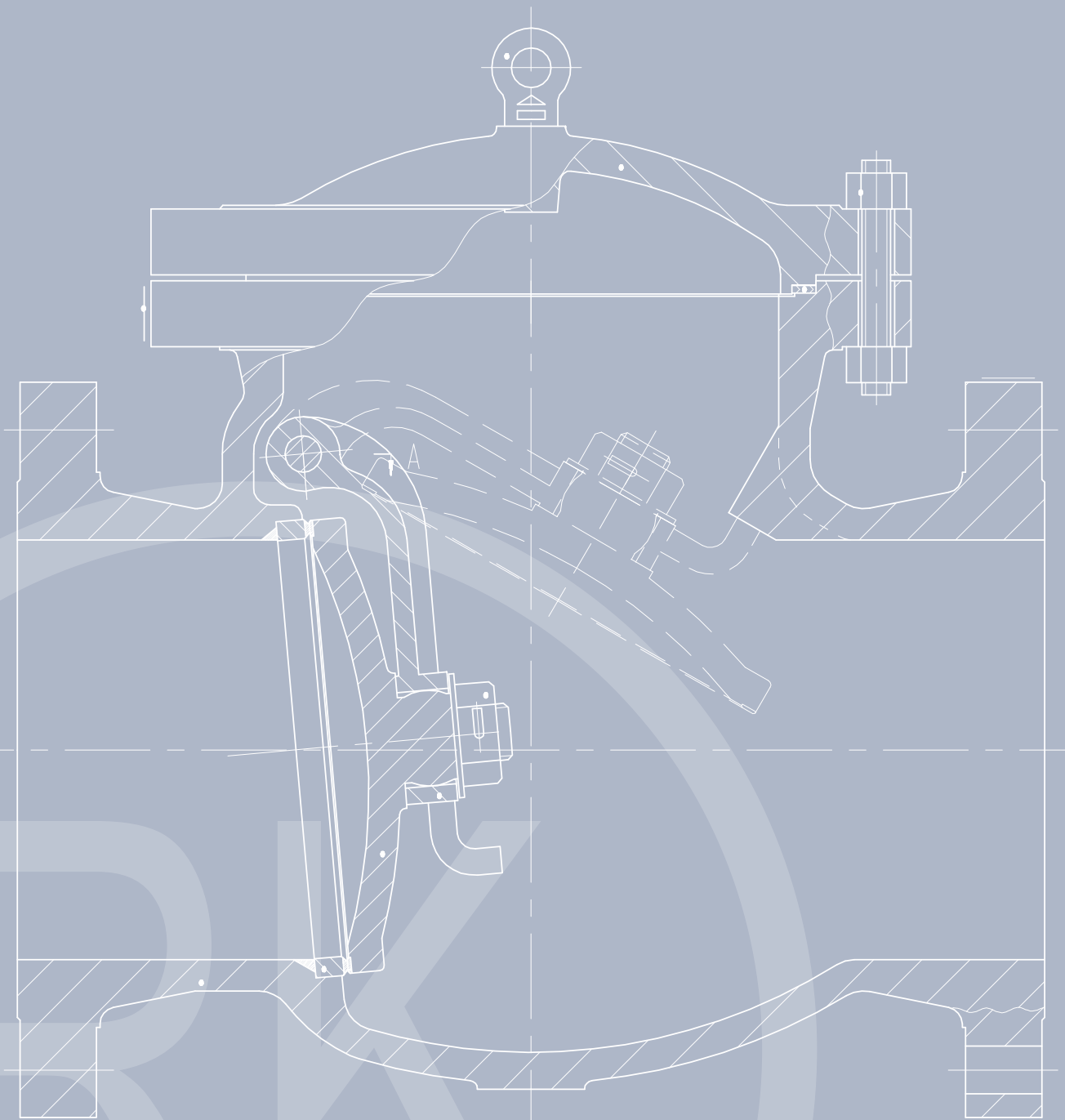

CHECKVALVES



VÁLVULAS DE RETENCIÓN - LISTA DE MATERIALES DE CONSTRUCCIÓN ESTÁNDAR

PIEZA	ACERO CARBONO		ACERO ALEADO				ACERO INOXIDABLE			
Cuerpo	A216 WCB	A352 LCB	A217 WC1	A217 WC6	A217 WC9	A217 C5	A351 CF8	A351 CF8M	A351 CF3	A351 CF3M
Tapa	A216 WCB	A352 LCB	A217 WC1	A217 WC6	A217 WC9	A217 C5	A351 CF8	A351 CF8M	A351 CF3	A351 CF3M
Biela	A216 WCB	A352 LCB	A217 WC1	A217 WC6	A217 WC9	A217 C5	A351 CF8	A351 CF8M	A351 CF3	A351 CF3M
Tornillo	A193 B7	A320 L7	A193 B7	A193 B16	A193 B16	A193 B16	A193 B8	A193 B8	A193 B8	A193 B8
Tuerca	A194 2H	A194 Gr. 4	A1974 2H	A194 Gr. 4	A194 Gr. 4	A194 Gr. 4	A194 Gr. 8	A194 Gr. 8	A194 Gr. 8	A194 Gr. 8
Tuerca Clapeta	410	410	410	410	410	410	316	316	316	316
Tornillo de presión	410	410	410	410	410	410	316	316	316	316
Tapón	Acero	Acero	Acero	Acero	Acero	Acero	Acero inox.	Acero inox.	Acero inox.	Acero inox.
Junta	Espirometálica Acero inox./Grafito o Acero inox./PTFE o Acero inox./PTFE reforzado									
Argolla	Acero									
Anillo de sellado	316L									
Placa identificación	Acero inoxidable o Aluminio									

Otros materiales (Alloy 20, AISI 321, AISI 347, Monel, Hastelloy, etc.) bajo demanda

MATERIALES DEL TRIM SEGÚN API 600¹

CÓDIGO ASIENTO	SUPERFICIE ASIENTO DEL CUERPO	SUPERFICIE ASIENTO DE LA CLAPETA	EJE DE BIELA
X	F6	F6	F6
U	Stellite	Stellite	F6
XU	Stellite	F6	F6
P	F304	F304	F304
R	F316	F316	F316
M	Monel	Monel	Monel
N	Alloy 20	Alloy 20	Alloy 20
H	Hastelloy B	Hastelloy B	Hastelloy B
B	Bronce	Bronce	Bronce

¹ Encontrará más información sobre materiales del trim al final de este catálogo

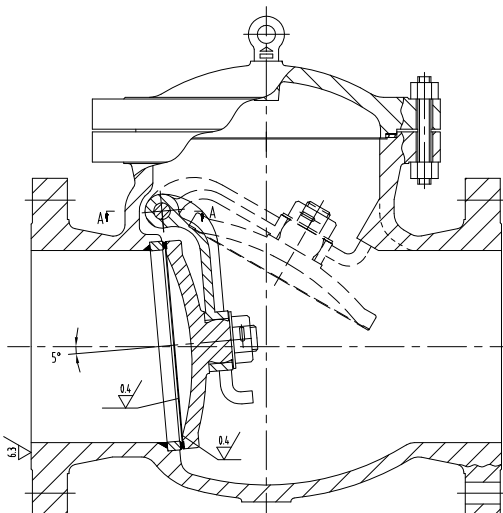

VÁLVULAS FUNDIDAS ANSI

RETENCIÓN 150LBS 2" - 6" BRIDAS

Retención Fig. SC01011XU		Clase: 150LBS
VÁLVULA RETENCIÓN ACERO CARBONO 150LBS BRIDAS		
Especificaciones		
Material	Acero carbono ASTM A216 WCB ¹	
Diseño	BS 1868	
Conexiones	Bridas según ASME B16.5 RF	
Longitud	ASME B16.10	
Inspección y Pruebas	API 598	
NACE MR 01-75	Bajo demanda	
Aplicaciones	Refinerías, Petroquímica, Química, Metalurgia, Papel, Farmacéuticas...	
¹ Ver lista de materiales estándar		

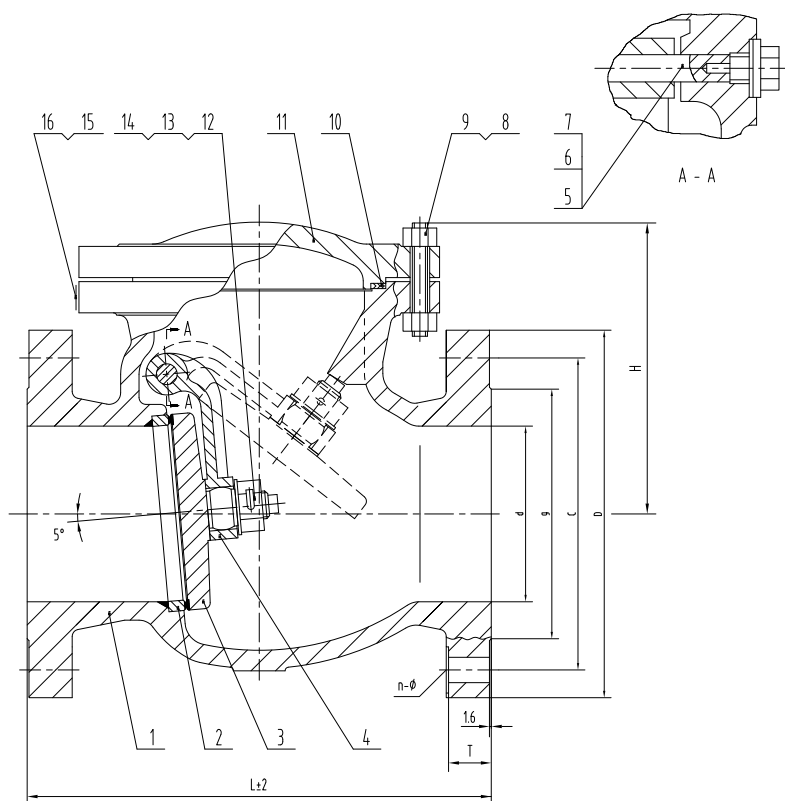
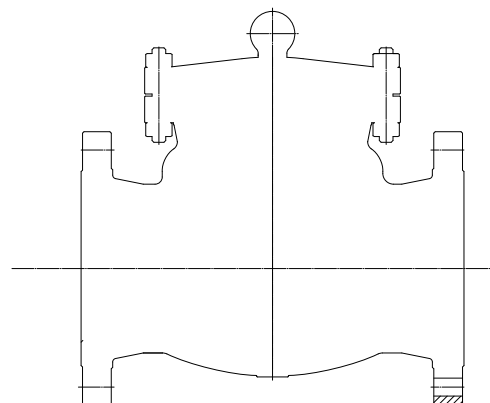

Componentes		
Pos.	Denominación	Material
1	Cuerpo	ASTM A216 WCB
2	Asientos	ASTM A105 +Stellite
3	Clapeta	ASTM A216 WCB ¹ +ER410
4	Biela	ASTM A216 WCB
5	Pasador	ASTM A276 410
6	Tapón	ASTM A276 410
7	Arandela	ASTM A240 304
8	Espárrago	ASTM A193 B7
9	Tuerca	ASTM A194 2H
10	Arandela	Espirometálica Grafito/Ac. inox.
11	Tapa	ASTM A216 WCB
12	Tuerca seguridad	ASTM A276 410
13	Junta cierre	ASTM A276 410
14	Cable	ASTM A276 304
15	Placa identificación	ASTM A240 321
16	Remache	ASTM A276 321

FIG. SC01011XU - RETENCIÓN A CLAPETA WCB/F6 XU TRIM N° 8 - 150LBS RF

Código	DN	d	g	C	D	T	n-Ø	L	H	Peso (kg)
010101302721529	2"	51	92	120.5	152	17.5	4-19	203	143	12
010101302721467	2.1/2"	64	105	139.5	178	19.5	4-19	216	165	18.1
010101302721530	3"	76	127	152.5	190	20.5	4-19	241	172	22.9
010101302721524	4"	102	157	190.5	229	24	8-19	292	196	36.5
-	5"	127	186	216	254	24	8-22	330	215	48.1
010101302721531	6"	152	216	241.5	279	26	8-22	356	231	58.9

RETENCIÓN 150LBS 2" - 6" BW

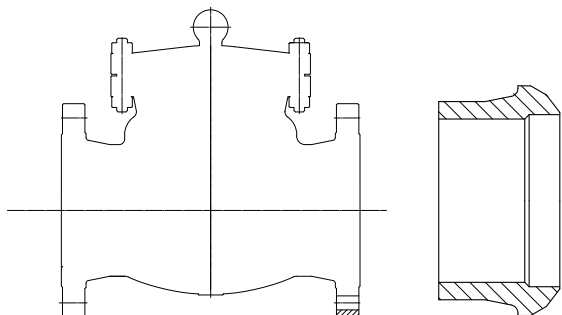

Retención Fig. SC01013XU		Clase: 150LBS
VÁLVULA RETENCIÓN ACERO CARBONO 150LBS BW		
Especificaciones		
Material	Acero carbono ASTM A216 WCB ¹	
Diseño	BS 1868	
Conexiones	Butt Weld según ASME B16.25	
Longitud	ASME B16.10	
Inspección y Pruebas	API 598	
NACE MR 01-75	Bajo demanda	
Aplicaciones	Refinerías, Petroquímica, Química, Metalurgia, Papel, Farmacéuticas...	
¹ Ver lista de materiales estándar		

Componentes		
Pos.	Denominación	Material
1	Cuerpo	ASTM A216 WCB
2	Asiento	ASTM A105 +Stellite
3	Clapeta	ASTM A216 WCB +Stellite
4	Biela	ASTM A216 WCB
5	Pasador	ASTM A276 410
6	Tapón	ASTM A276 410
7	Arandela	ASTM A276 304
8	Espárrago	ASTM A193 B7
9	Tuerca	ASTM A194 2H
10	Arandela	Espirometálica Grafito/SS
11	Tapa	ASTM A216 WCB
12	Tuerca	ASTM A276 410
13	Arandela bloqueo	ASTM A276 410
14	Pasador	ASTM A276 304
15	Chapa identificación	ASTM A240 321
16	Remache	ASTM A276 321

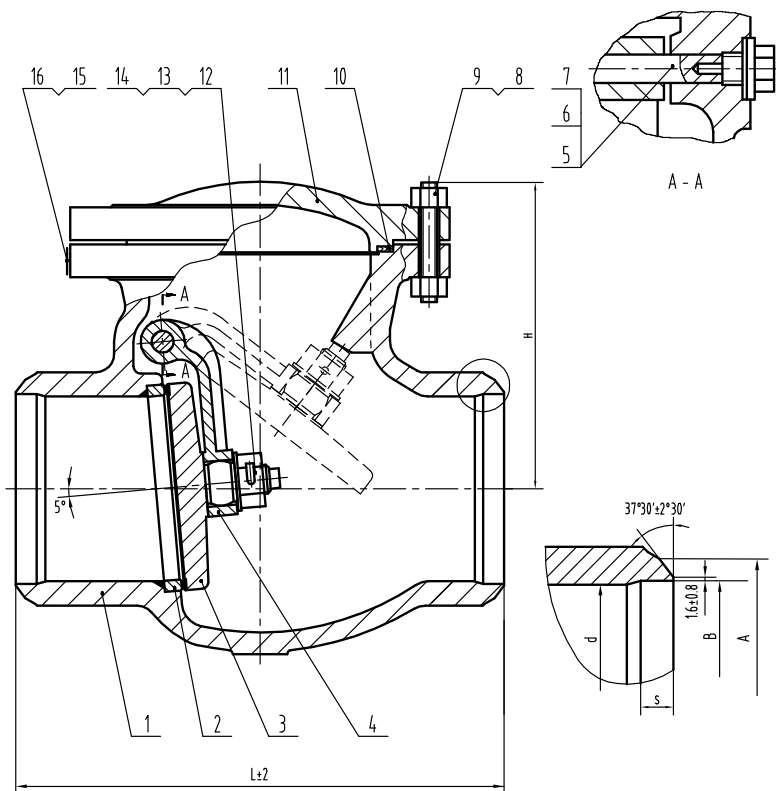

FIG. SC01013XU - RETENCIÓN A CLAPETA WCB/F6 XU TRIM N° 8 - 150LBS BW

Código	DN	d	SCH 40			SCH 80			SCH XS			L	H	Peso (kg)
			B	A	S	B	A	S	B	A	S			
-	2"	51	52.5	62	6	49	62	8.5				203	143	10.25
-	2.1/2"	64	62.5	75	8	59	75	10.5				216	165	15.43
-	3"	76	78	91	8.5	73.5	91	11.5				241	172	19.87
-	4"	102	102	117	9	97	117	13				292	196	31.61
-	5"	127	128	144	10	122	144	14.5				330	215	42.53
-	6"	152	154	172	11	146.5	172	16.5				356	231	52.04

VÁLVULAS FUNDIDAS ANSI

RETENCIÓN 150LBS 8" - 24" BRIDAS

Retención Fig. SC01011XU		Clase: 150LBS
VÁLVULA RETENCIÓN ACERO CARBONO 150LBS BRIDAS		
Especificaciones		
Material	Acero carbono ASTM A216 WCB ¹	
Diseño	BS 1868	
Conexiones	Bridas según ASME B16.5 RF	
Longitud	ASME B16.10	
Inspección y Pruebas	API 598	
NACE MR 01-75	Bajo demanda	
Aplicaciones	Refinerías, Petroquímica, Química, Metalurgia, Papel, Farmacéuticas...	
¹ Ver lista de materiales estándar		

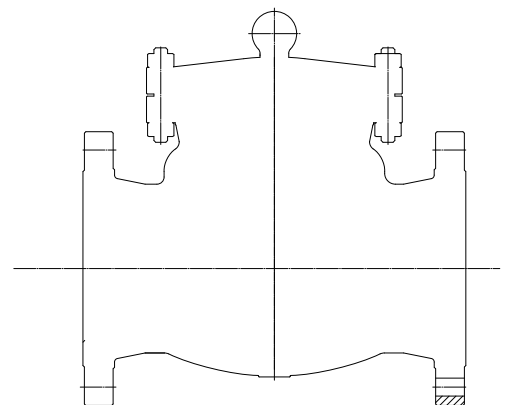

Componentes		
Pos.	Denominación	Material
1	Cuerpo	ASTM A216 WCB
2	Asiento	ASTM A105 +Stellite
3	Clapeta	ASTM A216 WCB +ER410
4	Biela	ASTM A216 WCB
5	Pasador	ASTM A276 410
6	Tapón	ASTM A276 410
7	Arandela	ASTM A240 304
8	Espárrago	ASTM A193 B7
9	Tuerca	ASTM A194 2H
10	Arandela	Espirometálica Grafito/SS
11	Tapa	ASTM A216 WCB
12	Tornillo	ASTM A29 1025
13	Tuerca seguridad	ASTM A276 410
14	Junta cierre	ASTM A276 410
15	Cable	ASTM A276 304
16	Placa identificación	ASTM A240 321
17	Remache	ASTM A276 321

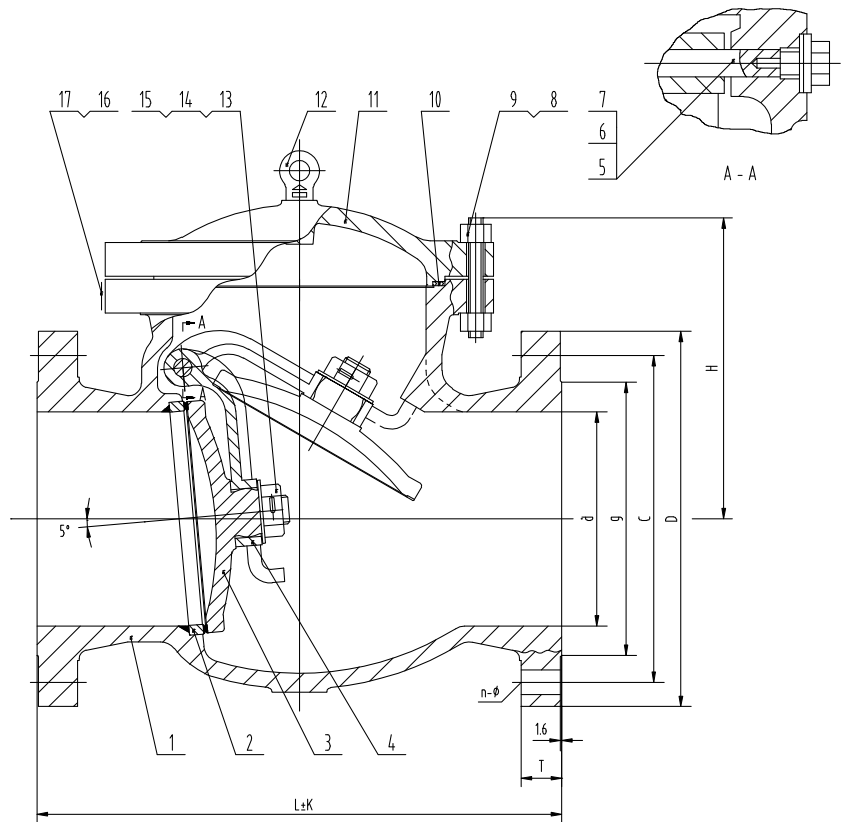
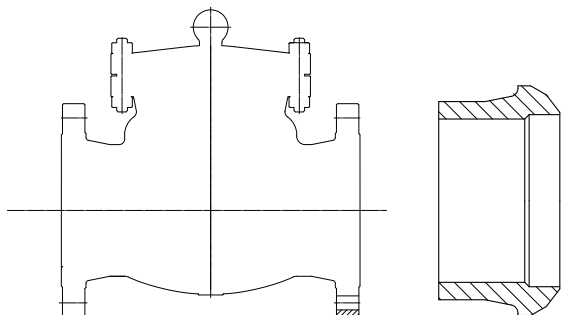

FIG. SC01011XU - RETENCIÓN A CLAPETA WCB/F6 XU TRIM N° 8 - 150LBS RF

Código	DN	d	g	C	D	T	L	K	n-Ø	H	Peso (kg)
010101302721468	8"	203	270	298.5	343	29	495	1.6	8-22	266	96.8
010101302721472	10"	254	324	362	406	31	622	1.6	12-25	304	147.6
010101302724157	12"	305	381	432	483	32	698	3.2	12-25	350	214.8
010101302722517	14"	337	413	476	533	35	787	3.2	12-29	380	277.7
010101302722529	16"	387	470	540	597	37	864	3.2	16-29	426	375.7
010101302722555	18"	438	533	578	635	40	978	3.2	16-32	446	457.1
010101302722177	20"	489	584	635	699	43	978	3.2	20-32	483	560.1
010101302722197	24"	591	692	749.5	813	48	1295	3.2	20-35	556	850.9

RETENCIÓN 150LBS 8" - 24" BW



Retención Fig. SC01013XU		Clase: 150LBS
VÁLVULA RETENCIÓN ACERO CARBONO 150LBS BW		
Especificaciones		
Material	Acero carbono ASTM A216 WCB ¹	
Diseño	BS 1868	
Conexiones	Butt Weld según ASME B16.25	
Longitud	ASME B16.10	
Inspección y Pruebas	API 598	
NACE MR 01-75	Bajo demanda	
Aplicaciones	Refinerías, Petroquímica, Química, Metalurgia, Papel, Farmacéuticas...	
¹ Ver lista de materiales estándar		

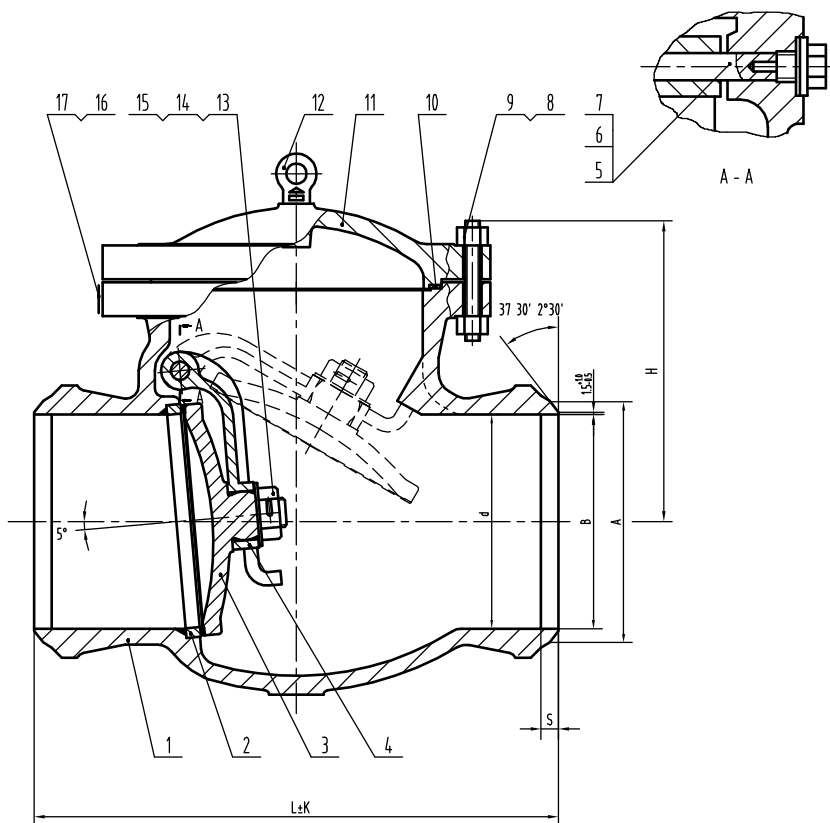

Componentes		
Pos.	Denominación	Material
1	Cuerpo	ASTM A216 WCB
2	Asiento	ASTM A105 +Stellite
3	Clapeta	ASTM A216 WCB + Stellite
4	Biela	ASTM A216 WCB
5	Pasador	ASTM A276 410
6	Tapón	ASTM A276 410
7	Arandela	ASTM A276 304
8	Espárrago	ASTM A193 B7
9	Tuerca	ASTM A194 2H
10	Arandela	Espirometálica Grafito/SS
11	Tapa	ASTM A216 WCB
12	Argolla	ASTM A29 1025
13	Tuerca	ASTM A276 410
14	Arandela bloqueo	ASTM A276 410
15	Pasador	ASTM A240 304
16	Chapa identificación	ASTM A240 321
17	Remache	ASTM A276 321

FIG. SC01013XU - RETENCIÓN A CLAPETA WCB/F6 XU TRIM N° 8 - 150LBS BW

Código	DN	d	SCH 40			SCH 80			SCH XS			L	K	H	Peso (kg)
			B	A	S	B	A	S	B	A	S				
-	8"	203	203	223	13	193.5	223	19				495	2	266	86.8
-	10"	254	254.5	278	14	243	278	23				622	2	304	133.6
-	12"	305	303	329	15	289	329	26				698	3	350	177.2
-	14"	337	333.5	362	15	317.5	362	28.5				787	3	380	250.7
-	16"	387	387.5	413	15	363.5	413	32				864	3	426	341.7
-	18"	438	438	464	15	409.5	464	36				978	3	446	438.1
-	20"	489	489	516	15	455.6	516	39				978	3	483	513.1
-	24"	591	590.5	619	15	547.7	619	46				1295	3	556	787.9

VÁLVULAS FUNDIDAS ANSI

RETENCIÓN 150LBS 26" - 36" BRIDAS

Retención		Clase: 150LBS
VÁLVULA RETENCIÓN ACERO CARBONO 150LBS BRIDAS		
Especificaciones		
Material	Acero carbono ASTM A216 WCB ¹	
Diseño	BS 1868	
Conexiones	Bridas según ASME B16.47A RF	
Longitud	ASME B16.10	
Inspección y Pruebas	API 598	
NACE MR 01-75	Bajo demanda	
Aplicaciones	Refinerías, Petroquímica, Química, Metalurgia, Papel, Farmacéuticas...	
¹ Ver lista de materiales estándar		

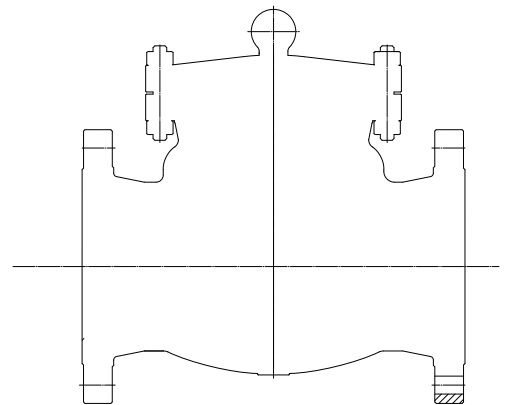

Componentes			
Pos.	Denominación	Cant.	Material
1	Cuerpo	1	ASTM A216 WCB
2	Asientos	1	ASTM A105 +Stellite
3	Clapeta	1	ASTM A216 WCB +13Cr
4	Biela	1	ASTM A216 WCB
5	Tuerca	1	ASTM A276 410
6	Arandela	1	ASTM A276 410
7	Pasador	1	ASTM A276 410
8	Remache	2	304SS
9	Placa identificación	1	304SS
10	Junta	1	Spirom. 304/Grafito
11	Tapa	1	ASTM A216 WCB
12	Tornillo de ojo	1	ANSI 1020
13	Tornillo cuerpo-tapa		ASTM A193 B7
14	Tuerca cuerpo-tapa		ASTM A194 2H
15	Junta	1	Spirom. 304/Grafito
16	Prensaestopas	1	ASTM A105
17	Tornillo	1	ANSI 1045

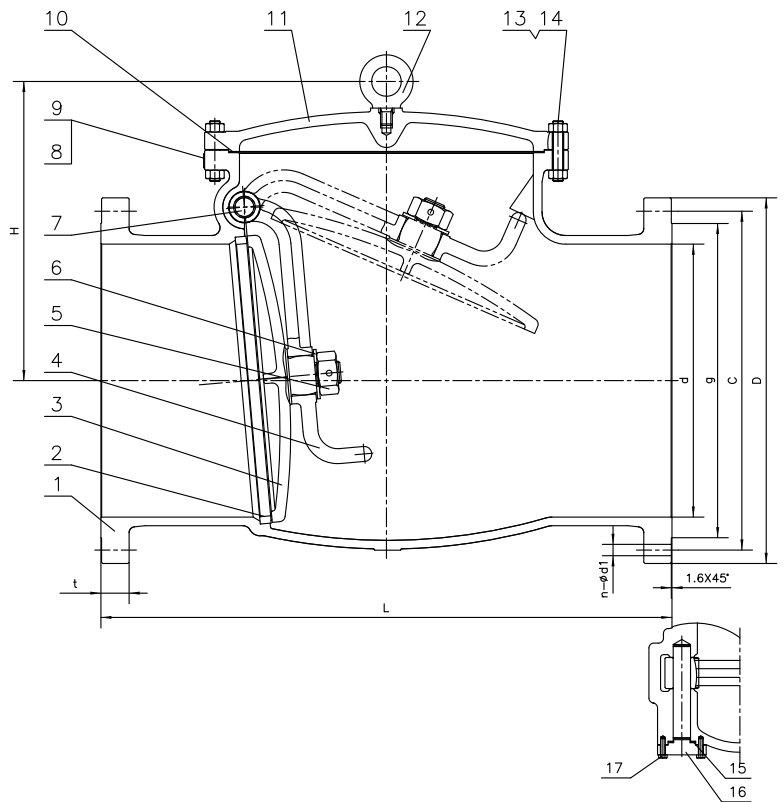

RETENCIÓN A CLAPETA WCB/F6 XU TRIM N° 8 - 150LBS RF

Código	DN	d	L	D	c	g	t	n	d1	H	Peso (kg)
-	26"	643	1.295	870	806,5	749	68,5	24	35	824	1.725
-	28"	692	1.448	927,1	863,6	800,1	71,5	28	35	896	1.965
-	30"	743	1.524	984	914,5	857	75	28	35	973	2.195
-	32"	781	1.626	1.060,5	977,9	914,5	81	28	42	1.025	3.250
-	36"	876	1.956	1.168	1.086	1.022	91	32	42	1.072	3.845

RETENCIÓN 300LBS 2" - 6" BRIDAS

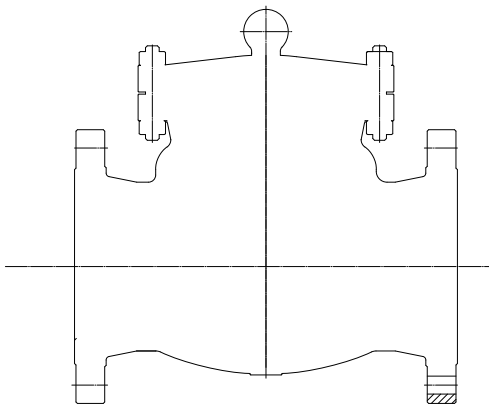

Retención Fig. SC03011XU		Clase: 300LBS
VÁLVULA RETENCIÓN ACERO CARBONO 300LBS BRIDAS		
Especificaciones		
Material	Acero carbono ASTM A216 WCB ¹	
Diseño	BS 1868	
Conexiones	Bridas según ASME B16.5 RF	
Longitud	ASME B16.10	
Inspección y Pruebas	API 598	
NACE MR 01-75	Bajo demanda	
Aplicaciones	Refinerías, Petroquímica, Química, Metalurgia, Papel, Farmacéuticas...	
¹ Ver lista de materiales estándar		

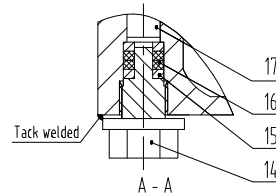
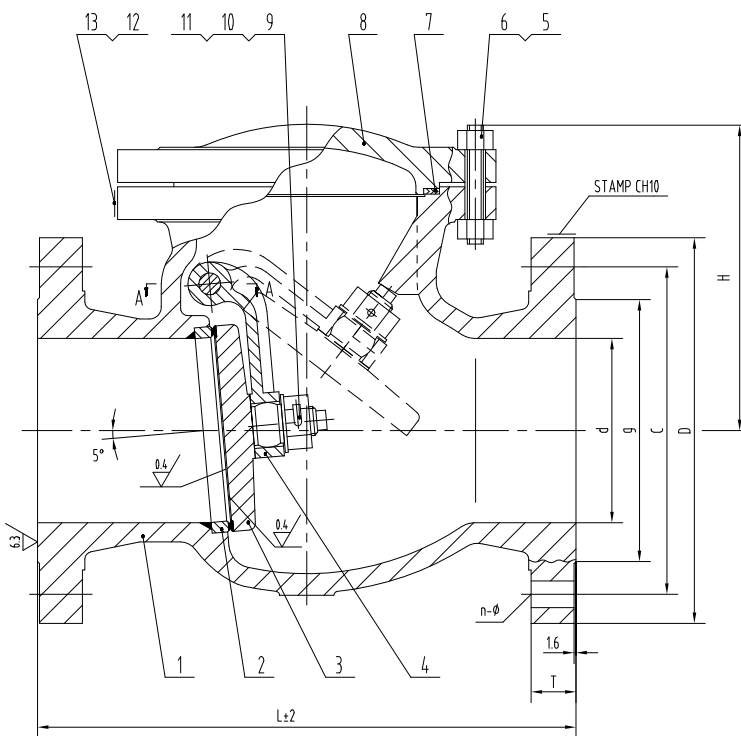

Pos.	Denominación	Componentes	
		Material	
1	Cuerpo	ASTM A216 WCB	
2	Asiento	ASTM A105 +Stellite	
3	Clapeta	ASTM A105 / AWS A5.9 ER410 Overlay	
4	Bielra	ASTM A216 WCB	
5	Tornillo	ASTM A193 B7	
6	Tuerca	ASTM A194 2H	
7	Junta	Espirometálica Grafito/316	
8	Tapa	ASTM A216 WCB	
9	Tuerca	ASTM A276 410	
10	Arandela	ASTM A276 410	
11	Alambre	ASTM A276 304	
12	Placa identificación	ASTM A240 321	
13	Remache	ASTM A276 321	
14	Tapón	ASTM A182 F6a Class 3	
15	Arandela	ASTM A276 410	
16	Empaquetadura	Grafito	
17	Pasador	ASTM A276 410	

FIG. SC03011XU - RETENCIÓN A CLAPETA WCB/F6 XU TRIM N° 8 - 300LBS RF

Código	DN	d	g	C	D	T	n-Ø	L	H	Peso (kg)
010101302721532	2"	51	92	127	165	23	8-19	267	158	17.2
010101302721533	2.1/2"									
010101302721534	3"	76	127	168.5	210	29	8-22	318	190	32.7
010101302721549	4"	102	157	200	254	32	8-22	356	214	49.7
-	5"									
010101302721536	6"	152	216	270	318	37	12-22	444	257	97.8

VÁLVULAS FUNDIDAS ANSI

RETENCIÓN 300LBS 2" - 6" BW

Retención Fig. SC03013XU		Clase: 300LBS
VÁLVULA RETENCIÓN ACERO CARBONO 300LBS BW		
Especificaciones		
Material	Acero carbono ASTM A216 WCB ¹	
Diseño	BS 1868	
Conexiones	Butt Weld según ASME B16.25	
Longitud	ASME B16.10	
Inspección y Pruebas	API 598	
NACE MR 01-75	Bajo demanda	
Aplicaciones	Refinerías, Petroquímica, Química, Metalurgia, Papel, Farmacéuticas...	
¹ Ver lista de materiales estándar		

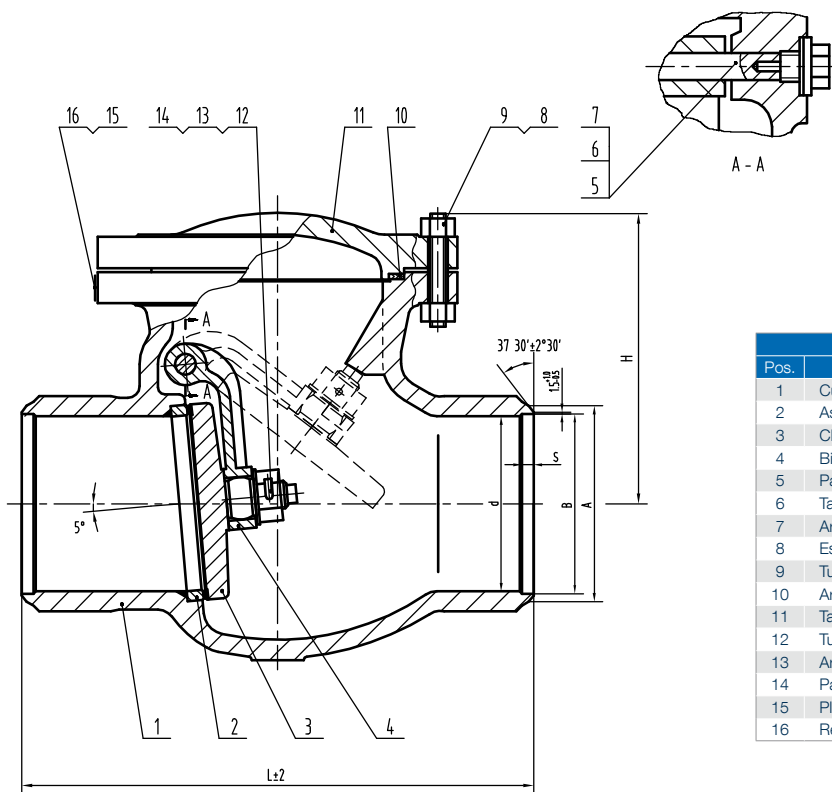
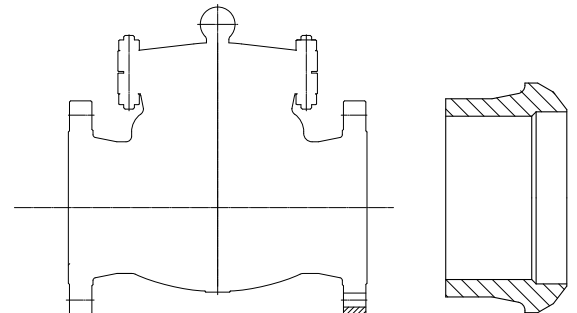

Pos.	Denominación	Componentes	
		Material	
1	Cuerpo	ASTM A216 WCB	
2	Asiento	ASTM A105 +Stellite	
3	Clapeta	ASTM A216 WCB (ASTM A105) + Cr13	
4	Bielra	ASTM A216 WCB	
5	Pasador	ASTM A276 410	
6	Tapón	ASTM A276 410	
7	Arandela	ASTM A276 304	
8	Espárrago	ASTM A193 B7	
9	Tuerca	Grafito / Acero inox.	
10	Arandela	ASTM A276 410	
11	Tapa	ASTM A216 WCB	
12	Tuerca	ASTM A276 410	
13	Arandela bloqueo	ASTM A276 410	
14	Pasador	ASTM A276 304	
15	Placa identificación	ASTM A240 321	
16	Remache	ASTM A276 321	

FIG. SC03013XU - RETENCIÓN A CLAPETA WCB/F6 XU TRIM Nº 8 - 300LBS RF

Código	DN	d	L	H	A	SCH 10		SCH 30		SCH 30		SCH 80 (XS)		Peso (kg)
						S	B	S	B	S	B	S	B	
-	2"	51	267	158	62	5	55	5	54	6	52.5	9	49.5	11.74
-	2.1/2"	64	292	172	75	5	67	8	63.5	8	62.5	11	59	16.33
-	3"	76	318	190	91	5	83	8	79.5	9	78	12	73.5	21.85
-	4"	102	356	214	117	5	108.5	8	105	10	102	13	97	31.82
-	5"	127	400	231	144	6	134.5			10	128	15	122	47.45
-	6"	152	444	257	172	6	161.5			11	154	17	146.5	68.8

RETENCIÓN 300LBS 8" - 24" BRIDAS

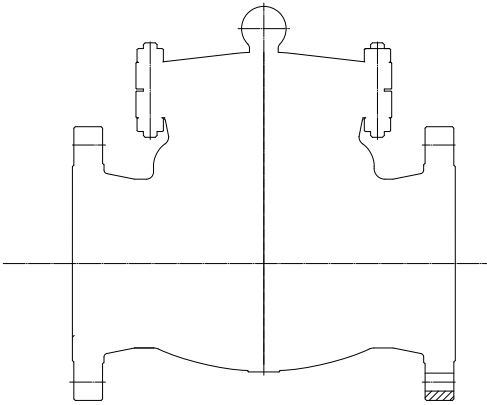

Retención Fig. SC03011XU		Clase: 300LBS
VÁLVULA RETENCIÓN ACERO CARBONO 300LBS BRIDAS		
Especificaciones		
Material	Acero carbono ASTM A216 WCB ¹	
Diseño	BS 1868	
Conexiones	Bridas según ASME B16.5 RF	
Longitud	ASME B16.10	
Inspección y Pruebas	API 598	
NACE MR 01-75	Bajo demanda	
Aplicaciones	Refinerías, Petroquímica, Química, Metalurgia, Papel, Farmacéuticas...	
¹ Ver lista de materiales estándar		

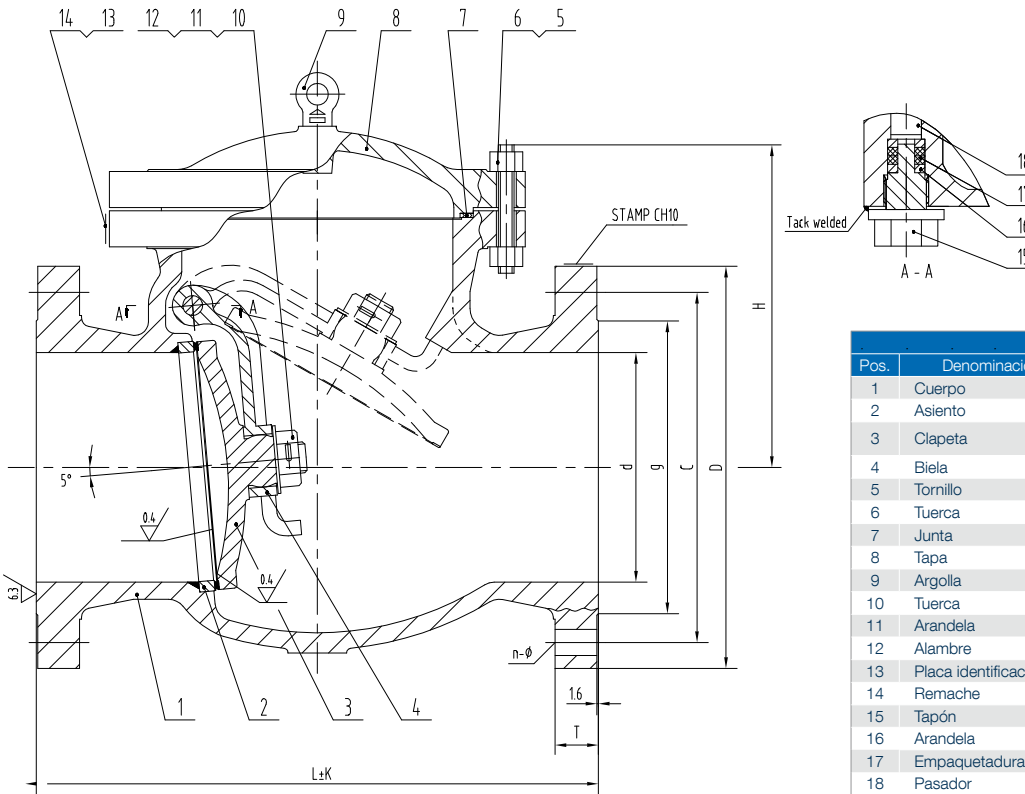

Componentes		
Pos.	Denominación	Material
1	Cuerpo	ASTM A216 WCB
2	Asiento	ASTM A105 +Stellite
3	Clapeta	ASTM A105 / AWS A5.9 ER410 Overlay
4	Bielra	ASTM A216 WCB
5	Tornillo	ASTM A193 B7
6	Tuerca	ASTM A194 2H
7	Junta	Espirometálica Grafito/316
8	Tapa	ASTM A216 WCB
9	Argolla	ASTM A129 1025
10	Tuerca	ASTM A276 410
11	Arandela	ASTM A276 410
12	Alambre	ASTM A276 304
13	Placa identificación	ASTM A240 321
14	Remache	ASTM A276 321
15	Tapón	ASTM A182 F6a Class 3
16	Arandela	ASTM A276 410
17	Empaquetadura	Grafito
18	Pasador	ASTM A276 410

FIG. SC03011XU - RETENCIÓN A CLAPETA WCB/F6 XU TRIM N° 8 - 300LBS RF

Código	DN	d	g	C	D	T	L	K	n-Ø	H	Peso (kg)
010101302721538	8"	203	270	330.0	381	42	533	2	12-25	302	157.2
010101302721527	10"	254	324	387.5	445	48	622	2	16-29	356	242.2
010101302721528	12"	305	381	451.0	521	51	711	3	16-32	399	342.4
010101302722467	14"	337	413	514.5	584	54	838	3	20-32	442	462.1
010101302722193	16"	387	470	571.5	648	58	864	3	20-35	461	605.7
-	18"	432	533	628.5	711	61	978	3	24-35	540	794.5
010101302720522	20"	483	584	686.0	775	64	1016	3	24-35	604	1028.6
-	24"	584	692	813	914	70	1346	3	24-41	694	1557.2

VÁLVULAS FUNDIDAS ANSI

RETENCIÓN 300LBS 8" - 24" BW

Retención Fig. SC03013XU		Clase: 300LBS
VÁLVULA RETENCIÓN ACERO CARBONO 300LBS BW		
Especificaciones		
Material	Acero carbono ASTM A216 WCB ¹	
Diseño	BS 1868	
Conexiones	Butt Weld según ASME B16.25	
Longitud	ASME B16.10	
Inspección y Pruebas	API 598	
NACE MR 01-75	Bajo demanda	
Aplicaciones	Refinerías, Petroquímica, Química, Metalurgia, Papel, Farmacéuticas...	
¹ Ver lista de materiales estándar		

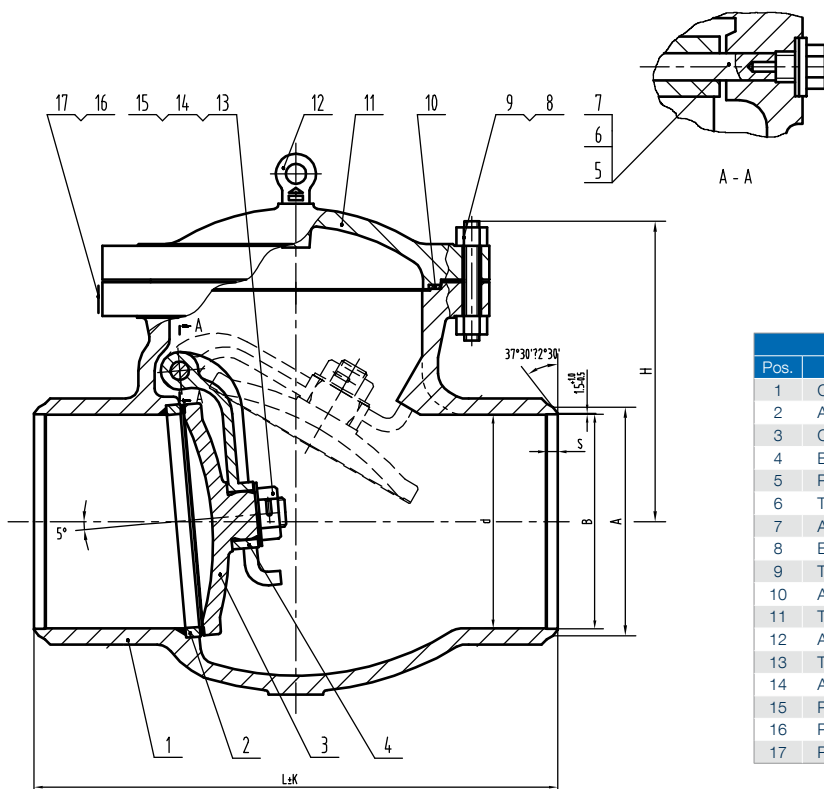
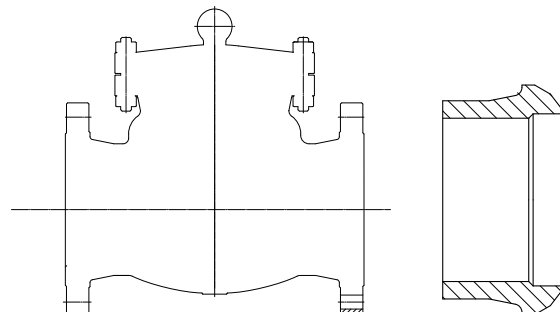

Componentes		
Pos.	Denominación	Material
1	Cuerpo	ASTM A216 WCB
2	Asiento	ASTM A105 +Stellite
3	Clapeta	ASTM A216 WCB + Cr13
4	Biela	ASTM A216 WCB
5	Pasador	ASTM A276 410
6	Tapón	ASTM A276 410
7	Arandela	ASTM A276 304
8	Espárrago	ASTM A193 B7
9	Tuerca	ASTM A194 2H
10	Arandela	Grafito / Acero inox.
11	Tapa	ASTM A216 WCB
12	Argolla	
13	Tuerca	ASTM A276 410
14	Arandela bloqueo	ASTM A276 410
15	Pasador	ASTM A276 304
16	Placa identificación	ASTM A240 321
17	Remache	ASTM A276 321

FIG. SC03013XU - RETENCIÓN A CLAPETA WCB/F6 XU TRIM N° 8 - 300LBS BW

Código	DN	d	SCH 40			SCH 80			SCH 80 (XS)			L	K	H	Peso (kg)
			B	A	S	B	A	S	B	A	S				
-	8"	203	203	223	12.3	193.5	223	19				533	2	302	111.6
-	10"	254	254.5	278	14	243	278	22.6				622	2	356	175.9
-	12"	305	303	329	15.5	289	329	26				711	3	399	248
-	14"	337	333.5	362	16.7	317.5	362	28.5				838	3	442	333
-	16"	387	381	413	19	363.5	413	32				864	3	461	441.8
-	18"	438	428.5	464	21.4	409.5	464	35.7				978	3	540	591
-	20"	489	478	516	22.6	455.5	516	39.3				1016	3	604	783.7
-	24"	591	574.5	619	26.2	547.5	619	46.4				1346	3	694	1197.5

RETENCIÓN 300LBS 26" - 36" BRIDAS

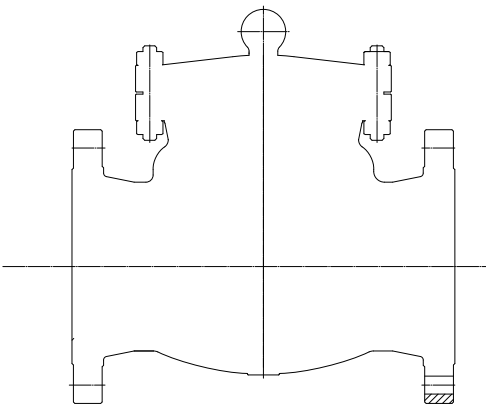

Retención		Clase: 300LBS
VÁLVULA RETENCIÓN ACERO CARBONO 300LBS BRIDAS		
Especificaciones		
Material	Acero carbono ASTM A216 WCB ¹	
Diseño	BS 1868	
Conexiones	Bridas según ASME B16.47A RF	
Longitud	ASME B16.10	
Inspección y Pruebas	API 598	
NACE MR 01-75	Bajo demanda	
Aplicaciones	Refinerías, Petroquímica, Química, Metalurgia, Papel, Farmacéuticas...	
¹ Ver lista de materiales estándar		

Componentes			
Pos.	Denominación	Cant.	Material
1	Cuerpo	1	ASTM A216 WCB
2	Asiento	1	ASTM A105 +Stellite
3	Clapeta	1	ASTM WCB +13Cr
4	Tuerca	1	ASTM A276 410
5	Biela	1	ASTM A216 WCB
6	Arandela	1	ASTM A276 410
7	Pasador	1	ASTM A276 410
8	Remache	2	304SS
9	Placa identificación	1	304SS
10	Junta cuerpo-tapa	1	Spirom. 304/Grafito
11	Tapa	1	ASTM A216 WCB
12	Tornillo de ojo	1	ANSI 1020
13	Tornillo cuerpo-tapa		ASTM A193 B7
14	Tuerca cuerpo-tapa		ASTM A194 2H
15	Junta	1	Spirom. 304/Grafito
16	Prensaestopas	1	ASTM A105
17	Tornillo	1	ANSI 1045

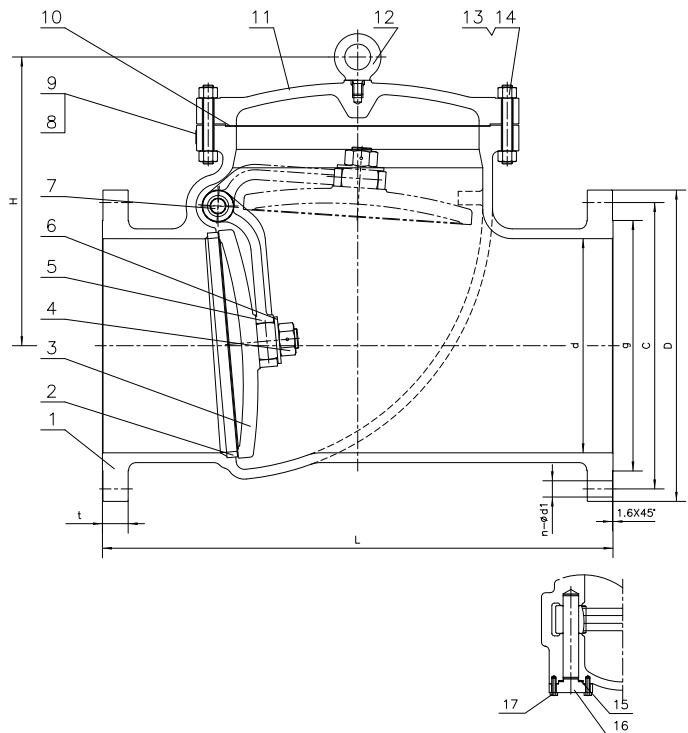

RETENCIÓN A CLAPETA WCB/F6 XU TRIM N° 8 - 300LBS RF

Código	DN	d	L	D	c	g	t	n	d1	H	Peso (kg)
-	26"	635	1.346	971,6	876,3	749,3	79,5	28	45	824	2.570
-	28"	686	1.499	1.035	939,8	800,1	86	28	45	896	2.865
-	30"	737	1.594	1.090	997	857	92,5	28	48	973	3.385
-	32"	781	1.727	1.150	1.054	914,4	98,6	28	51	1.025	4.520
-	36"	876	2.083	1.270	1.168,4	1.022	105	32	54	1.072	5.845

VÁLVULAS FUNDIDAS ANSI

RETENCIÓN 600LBS 2" - 6" BRIDAS

Retención Fig. SC06011XU		Clase: 600LBS
VÁLVULA RETENCIÓN ACERO CARBONO 600LBS BRIDAS		
Especificaciones		
Material	Acero carbono ASTM A216 WCB ¹	
Diseño	BS 1868	
Conexiones	Bridas según ASME B16.5 RF	
Longitud	ASME B16.10	
Inspección y Pruebas	API 598	
NACE MR 01-75	Bajo demanda	
Aplicaciones	Refinerías, Petroquímica, Química, Metalurgia, Papel, Farmacéuticas...	
¹ Ver lista de materiales estándar		

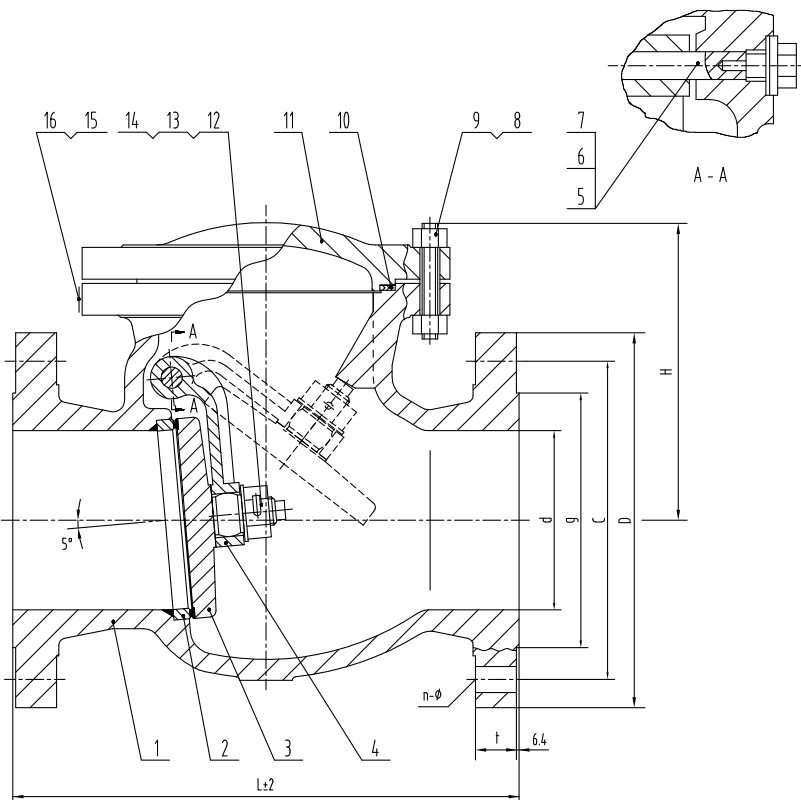
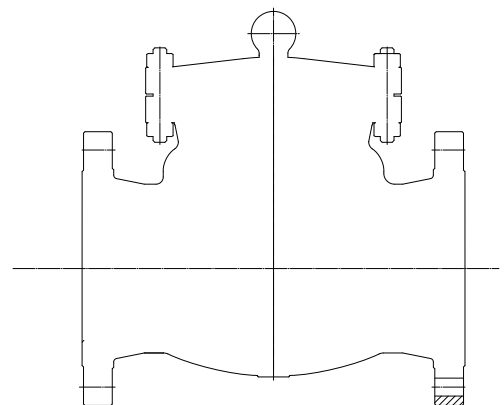

Componentes		
Pos.	Denominación	Material
1	Cuerpo	ASTM A216 WCB
2	Asiento	ASTM A105 +Stellite 6
3	Clapeta	ASTM A105 +ER410
4	Bielra	ASTM A216 WCB
5	Pasador	ASTM A276 410
6	Tapón	ASTM A276 410
7	Junta tapón	ASTM A276 304
8	Espárrago	ASTM A193 B7
9	Tuerca	ASTM A194 2H
10	Junta	S6590
11	Tapa	ASTM A216 WCB
12	Tuerca seguridad	ASTM A276 410
13	Arandela seguridad	ASTM A276 410
14	Alambre	ASTM A276 304
15	Placa identificación	ASTM A240 321
16	Remache	ASTM A276 321

FIG. SC06011XU - RETENCIÓN A CLAPETA WCB/F6 XU TRIM N° 8 - 600LBS RF

Código	DN	d	g	C	D	T	n-Ø	L	H	Peso (kg)
010101302721469	2"	51	92	127	165	26	8-19	292	171	21.0
	2.1/2"	64	105	149	190	29	8-22	330	189	28.8
010101302721470	3"	76	127	168	210	32	8-22	356	207	39.5
010101302721471	4"	102	157	216	273	38	8-25	432	249	70.8
-	5"	127	186	266.5	330	45	8-29	508	295	116.6
010101302721510	6"	152	216	292	356	48	12-29	559	320	154.3

RETENCIÓN 600LBS 2" - 6" BW

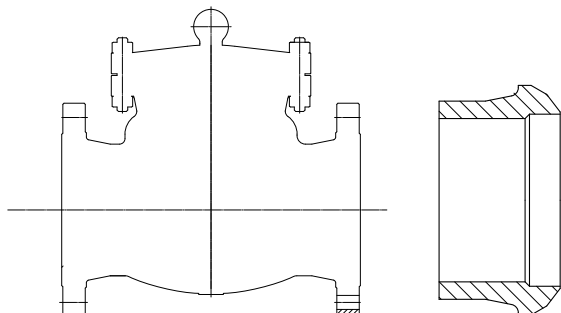

Retención Fig. SC06013XU		Clase: 600LBS
VÁLVULA RETENCIÓN ACERO CARBONO 600LBS BW		
Especificaciones		
Material	Acero carbono ASTM A216 WCB ¹	
Diseño	BS 1868	
Conexiones	Butt Weld según ASME B16.25	
Longitud	ASME B16.10	
Inspección y Pruebas	API 598	
NACE MR 01-75	Bajo demanda	
Aplicaciones	Refinerías, Petroquímica, Química, Metalurgia, Papel, Farmacéuticas...	
¹ Ver lista de materiales estándar		

Componentes		
Pos.	Denominación	Material
1	Cuerpo	ASTM A216 WCB
2	Asiento	ASTM A105 +Stellite
3	Clapeta	ASTM A105 +13Cr
4	Biela	ASTM A216 WCB
5	Pasador	ASTM A276 410
6	Tapón	ASTM A276 410
7	Arandela	ASTM A276 304
8	Espárrago	ASTM A193 B7
9	Tuerca	ASTM A194 2H
10	Junta cuerpo-tapa	ASTM A182 F304
11	Tapa	ASTM A216 WCB
12	Tuerca	ASTM A276 410
13	Arandela bloqueo	ASTM A276 410
14	Pasador	ASTM A276 304
15	Chapa identificación	ASTM A240 321
16	Remache	ASTM A276 321

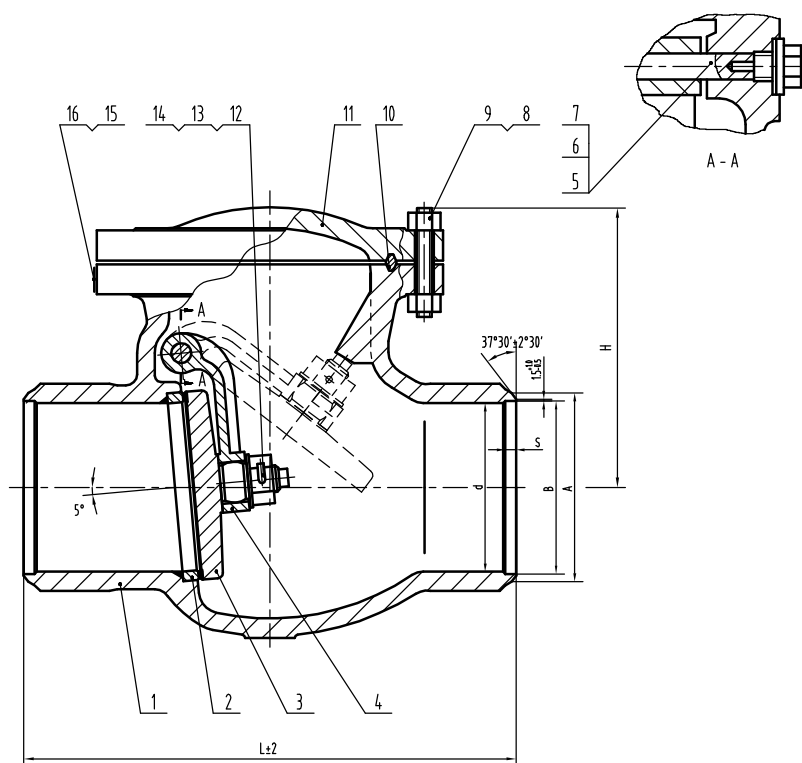

FIG. SC06013XU - RETENCIÓN A CLAPETA WCB/F6 XU TRIM N° 8 - 600LBS BW

Código	DN	d	SCH 40			SCH 80			SCH 120			L	H	Peso (kg)
			B	A	S	B	A	S	B	A	S			
-	2"	51	52.5	62	6	49	62	8.5	46	60.3	14	292	171	21
-	2.1/2"	64	62.5	75	8	59	75	10.5				330	189	28.8
-	3"	76	78	91	8.5	73.5	91	11.5				356	207	39.5
-	4"	102	102	117	9	97	117	13	92	117	16.7	432	249	70.8
-	5"	127	128	144	10	122	144	14.5	116	144	19	508	295	116.6
-	6"	152	154	172	11	146.5	172	16.5	140	172	21.4	559	320	154.3

VÁLVULAS FUNDIDAS ANSI

RETENCIÓN 600LBS 8" - 24" BRIDAS

Retención Fig. SC06011XU		Clase: 600LBS
VÁLVULA RETENCIÓN ACERO CARBONO 600LBS BRIDAS		
Especificaciones		
Material	Acero carbono ASTM A216 WCB ¹	
Diseño	BS 1868	
Conexiones	Bridas según ASME B16.5 RF	
Longitud	ASME B16.10	
Inspección y Pruebas	API 598	
NACE MR 01-75	Bajo demanda	
Aplicaciones	Refinerías, Petroquímica, Química, Metalurgia, Papel, Farmacéuticas...	
¹ Ver lista de materiales estándar		

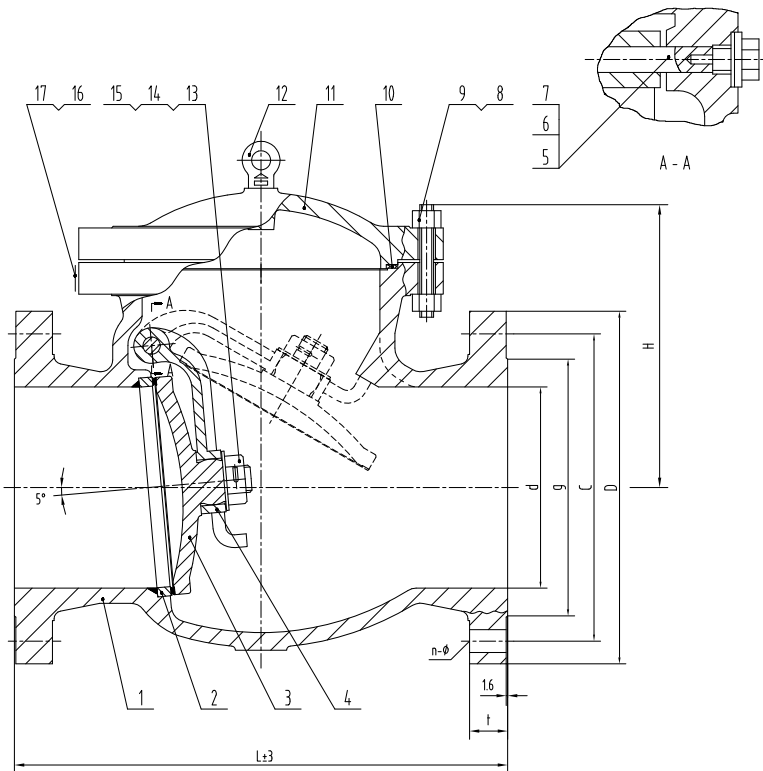
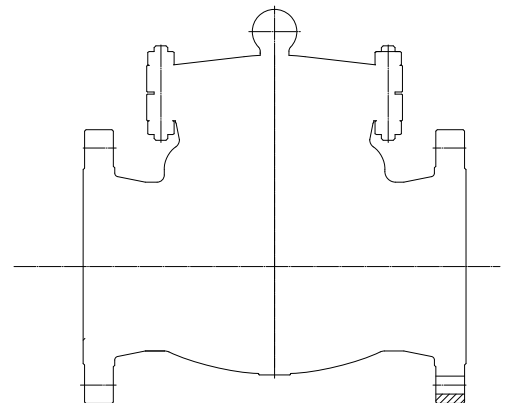

Componentes		
Pos.	Denominación	Material
1	Cuerpo	ASTM A216 WCB
2	Asiento	ASTM A105 +Stellite 6
3	Clapeta	ASTM A105 +ER410
4	Bielta	ASTM A216 WCB
5	Pasador	ASTM A276 410
6	Tapón	ASTM A276 410
7	Junta tapón	ASTM A276 304
8	Espárrago	ASTM A193 B7
9	Tuerca	ASTM A194 2H
10	Junta	S6590
11	Tapa	ASTM A216 WCB
12	Tornillo	ASTM A29 1025
13	Tuerca seguridad	ASTM A276 410
14	Arandela seguridad	ASTM A276 410
15	Alambre	ASTM A276 304
16	Placa identificación	ASTM A240 321
17	Remache	ASTM A276 321

FIG. SC06011XU - RETENCIÓN A CLAPETA WCB/F6 XU TRIM N° 8 - 600LBS RF

Código	DN	d	g	C	D	T	n-Ø	L	H	Peso (kg)
010101302721487	8"	200	270	349	419	56	12-32	660	367	264.5
010101302721548	10"	248	324	432	508	64	16-35	787	433	425.1
010101302722079	12"	298	381	489	559	67	20-35	838	485	594.5
-	14"	327	413	527	603	70	20-38	889	522	749.2
-	16"	375	470	603	686	77	20-41	991	580	1029.9
-	18"	419	533	654	743	83	20-44	1092	627	1317.8
-	20"	464	584	724	813	89	24-44	1194	674	1687.6
-	24"	559	692	838	940	102	24-52	1397	777	2786.6

RETENCIÓN 600LBS 26" - 36" BRIDAS

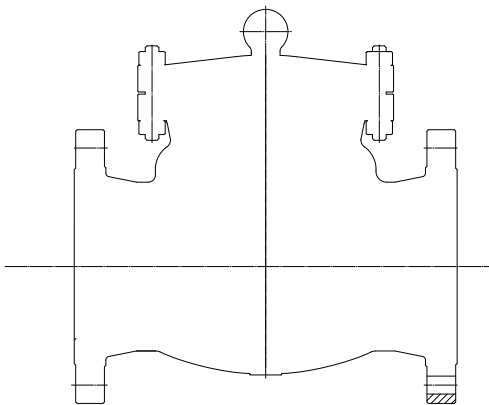

Retención		Clase: 600LBS
VÁLVULA RETENCIÓN ACERO CARBONO 600LBS BRIDAS		
Especificaciones		
Material	Acero carbono ASTM A216 WCB ¹	
Diseño	BS 1868	
Conexiones	Bridas según ASME B16.47A RF	
Longitud	ASME B16.10	
Inspección y Pruebas	API 598	
NACE MR 01-75	Bajo demanda	
Aplicaciones	Refinerías, Petroquímica, Química, Metalurgia, Papel, Farmacéuticas...	
¹ Ver lista de materiales estándar		

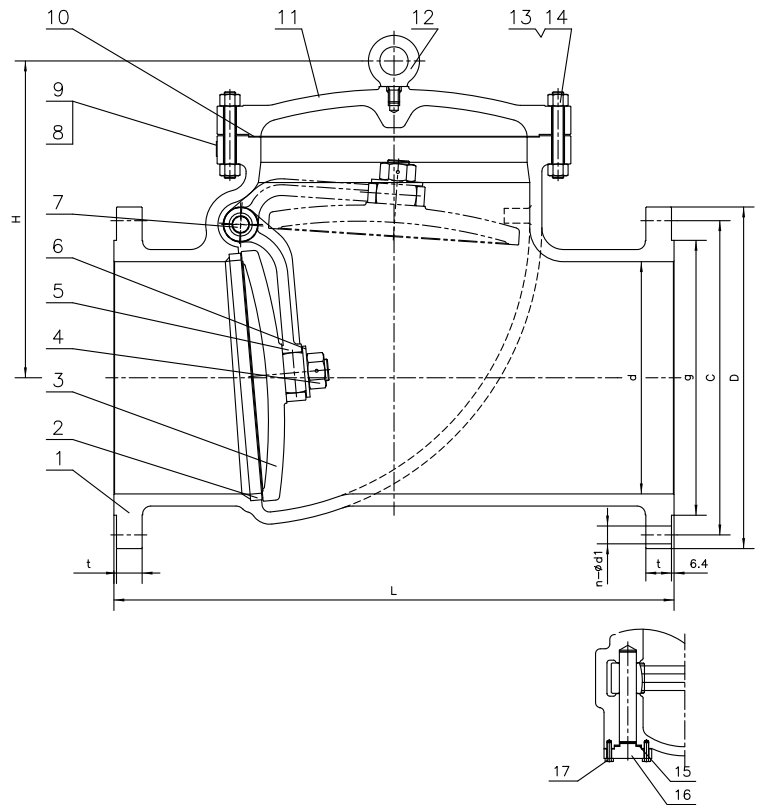

Componentes			
Pos.	Denominación	Cant.	Material
1	Cuerpo	1	ASTM A216 WCB
2	Asiento	1	ASTM A105 +Stellite 6
3	Clapeta	1	ASTM WCB +13Cr
4	Tuerca	1	ASTM A276 410
5	Biela	1	ASTM A216 WCB
6	Arandela	1	ASTM A276 410
7	Pasador	1	ASTM A276 410
8	Remache	2	304SS
9	Placa identificación	1	304SS
10	Junta cuerpo-tapa	1	Spirom. 304/Grafito
11	Tapa	1	ASTM A216 WCB
12	Tornillo de ojo	1	ANSI 1020
13	Tornillo cuerpo-tapa		ASTM A193 B7
14	Tuerca cuerpo-tapa		ASTM A194 2H
15	Junta	1	Spirom. 304/Grafito
16	Prensaestopas	1	ASTM A105
17	Tornillo	1	ANSI 1045

RETENCIÓN A CLAPETA WCB/F6 XU TRIM N° 8 - 600LBS RF

Código	DN	d	L	D	c	g	t	n	d1	H	Peso (kg)
-	26"	603	1.448	1.015	914,4	749	108	28	51	842	3.850
-	28"	648	1.600	1.073,2	965,2	800,1	111,2	28	54	957	4.582
-	30"	695	1.651	1.130	1.022,4	857	115	28	54	1.035	6.378
-	32"	781	1.778	1.195	1.079,5	914	118	28	61	1.113	8.360
-	36"	876	2.083	1.315	1.194	1.022	124	28	67	1.268	9.631

VÁLVULAS FUNDIDAS ANSI

RETENCIÓN 900LBS 2" - 6" DISEÑO PRESSURE SEAL

Retención Fig. SC09013XU		Clase: 900LBS
VÁLVULA RETENCIÓN ACERO CARBONO 900LBS SOLDAR		
Especificaciones		
Material	Acero carbono ASTM A216 WCB ¹	
Diseño	BS 1868	
Conexiones	Butt Welding según ASME B16.25	
Longitud	ASME B16.10	
Inspección y Pruebas	API 598	
NACE MR 01-75	Bajo demanda	
Aplicaciones	Refinerías, Petroquímica, Química, Metalurgia, Papel, Farmacéuticas...	
¹ Ver lista de materiales estándar		

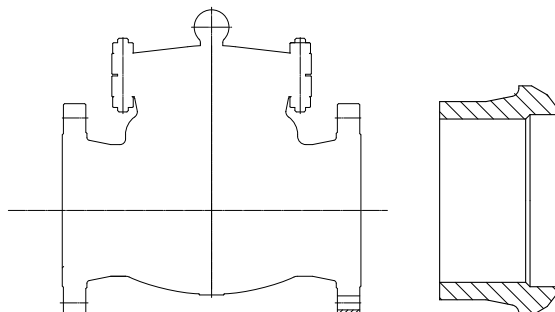

Componentes		
Pos.	Denominación	Material
1	Cuerpo	ASTM A216 WCB
2	Asiento	ASTM A105 +Stellite
3	Clapeta	ASTM A105 +ER410
4	Biela	ASTM A216 WCB
5	Tornillo	ASTM A276 304
6	Bulón	ASTM A276 410
7	Placa identificación	ASTM A240 321
8	Remache	ASTM A276 321
9	Espárrago	ASTM A193 B7
10	Tuerca	ASTM A194 2H
11	Tapa	ASTM A105
12	Bonete	ASTM A105
13	Tornillo	ASTM A29 1025
14	Anillo segmentado	ASTM A29 1045
15	Arandela	ASTM A36
16	Anillo sellado	ASTM A182 F304
17	Anillo	ASTM A105
18	SopORTE biela	ASTM A216 WCB
19	Pasador	ASTM A276 410
20	Tuerca	ASTM A276 410
21	Arandela cierre	ASTM A276 410
22	Alambre acero	ASTM A276 304

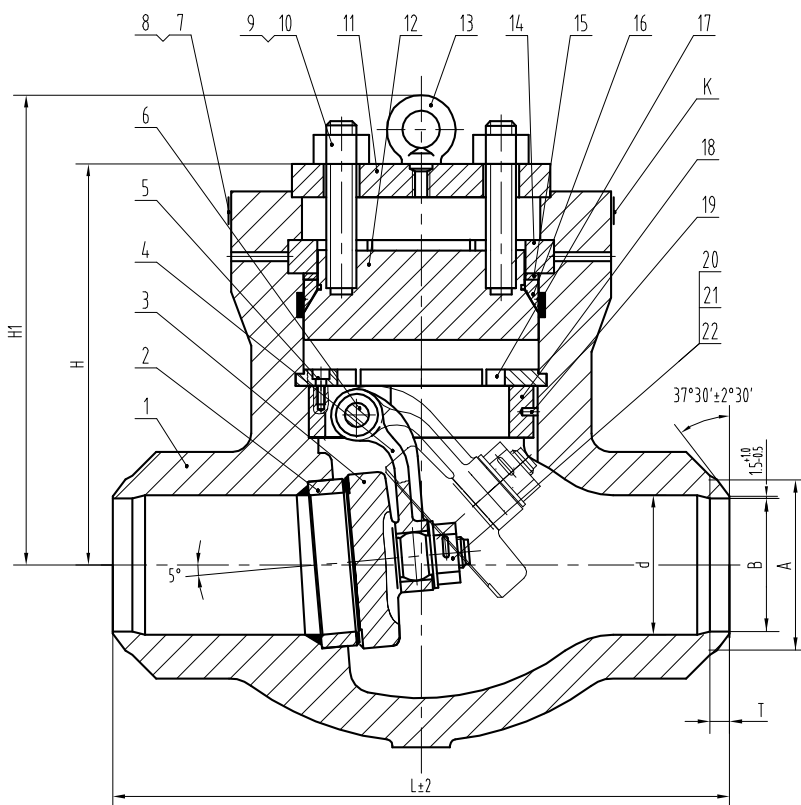
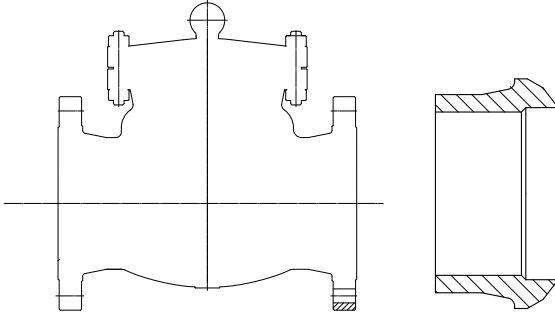

FIG. SC09013XU - RETENCIÓN A CLAPETA WCB/F6 XU TRIM N° 8 - 900LBS BW

Código	DN	d	L	H	H1	A	SCH80		SCH100		SCH120		SCH140		SCHXXS		SCH160		Peso (kg)
							T	B	T	B	T	B	T	B	T	B			
-	2"	48	216	183		62	9	49.0									14	43.0	23.0
-	3"	73	305	209		91	12	73.5									17	66.5	37.8
-	4"	98	356	240	284	117	13	97.0			17	92					21	87.5	63.0
-	6"	146	508	305	357	172	17	146.5			22	140					28	132	138.0

RETENCIÓN 900LBS 8" - 16" DISEÑO PRESSURE SEAL



Retención Fig. SC09013XU		Clase: 900LBS
VÁLVULA RETENCIÓN ACERO CARBONO 900LBS SOLDAR		
Especificaciones		
Material	Acero carbono ASTM A216 WCB ¹	
Diseño	BS 1868	
Conexiones	Butt Welding según ASME B16.25	
Longitud	ASME B16.10	
Inspección y Pruebas	API 598	
NACE MR 01-75	Bajo demanda	
Aplicaciones	Refinerías, Petroquímica, Química, Metalurgia, Papel, Farmacéuticas...	
¹ Ver lista de materiales estándar		

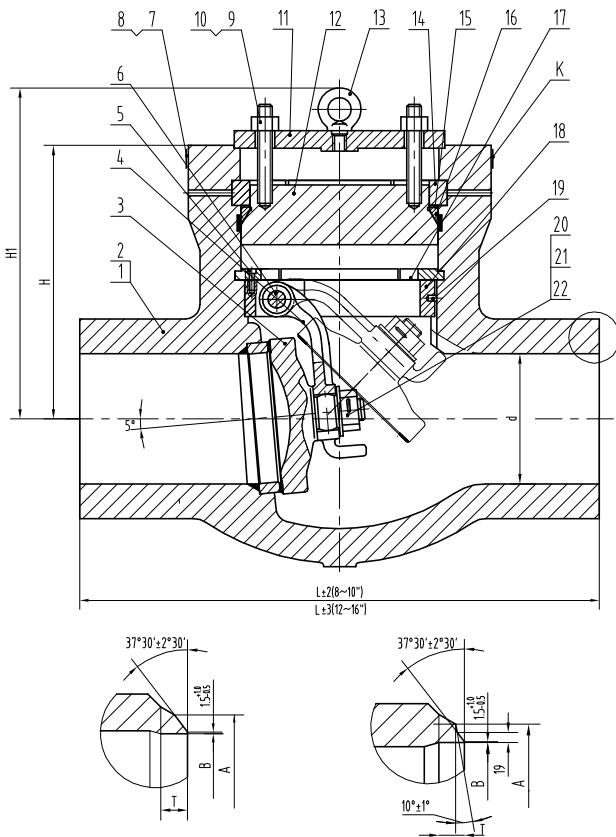

Componentes		
Pos.	Denominación	Material
1	Cuerpo	ASTM A216 WCB
2	Asiento	ASTM A105 +Stellite
3	Clapeta	ASTM A105 +ER410
4	Biela	ASTM A216 WCB
5	Tornillo	ASTM A276 304
6	Bulón	ASTM A276 410
7	Placa identificación	ASTM A240 321
8	Remache	ASTM A276 321
9	Espárrago	ASTM A193 B7
10	Tuerca	ASTM A194 2H
11	Tapa	ASTM A105
12	Bonete	ASTM A105
13	Tornillo	ASTM A29 1025
14	Anillo segmentado	ASTM A29 1045
15	Arandela	ASTM A36
16	Anillo sellado	ASTM A182 F304
17	Anillo	ASTM A105
18	Soporte biela	ASTM A216 WCB
19	Pasador	ASTM A276 410
20	Tuerca	ASTM A276 410
21	Arandela cierre	ASTM A276 410
22	Alambre acero	ASTM A276 304

FIG. SC09013XU - RETENCIÓN A CLAPETA WCB/F6 XU TRIM N° 8 - 900LBS BW

Código	DN	d	L	H	H1	A	SCH80		SCH100		SCH120		SCH140		SCHXXS		SCH160		Peso (kg)
							T	B	T	B	T	B	T	B	T	B			
-	8"	191	660	350	412	223	20	193.5	23	189.0	28	182.5	31	178.0	34	174.5	35	173	263.5
-	10"	238	787	407	479	278	23	243.0	28	236.5	33	230.0	39	222.0			43	216	429.8
-	12"	283	914	462	550	329	27	289.0	33	281.0	39	273.0	43	266.5			50	257	667.1
-	14"	311	991	508	613	362	29	317.5	36	308.0	42	300.0	48	292.0			54	284	874.9
-	16"	356	1092	565	670	413	33	363.5	40	354.0	47	344.5	55	333.5			61	325.5	1251.9

VÁLVULAS FUNDIDAS ANSI

RETENCIÓN 900LBS 18" - 20" DISEÑO PRESSURE SEAL

Retención		Clase: 900LBS
VÁLVULA RETENCIÓN ACERO CARBONO 900LBS SOLDAR		
Especificaciones		
Material	Acero carbono ASTM A216 WCB ¹	
Diseño	BS 1868	
Conexiones	Butt Welding según ASME B16.25	
Longitud	ASME B16.10	
Inspección y Pruebas	API 598	
NACE MR 01-75	Bajo demanda	
Aplicaciones	Refinerías, Petroquímica, Química, Metalurgia, Papel, Farmacéuticas...	
¹ Ver lista de materiales estándar		

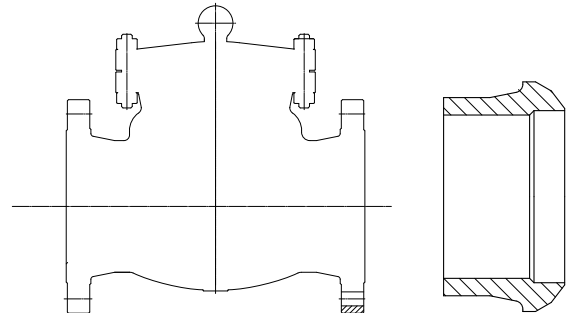

Componentes		
Pos.	Denominación	Material
1	Cuerpo	ASTM A216 WCB
2	Asiento	ASTM A105 +Stellite 6
3	Clapeta	ASTM A105 +Stellite 6
4	Biela	ASTM A216 WCB
5	Tornillo	Acero carbono
6	Bulón	A276 410
7	Remache	AISI 304
8	Placa identificación	AISI 304
9	Tuerca	A194 2H
10	Tornillo	A193 B7
11	Retén bonete	A105
12	Bonete	A105 +13% Cr
13	Argolla	ANSI 1025
14	Anillo segmentado	ANSI 1045
15	Anillo espaciador	ANSI 1045
16	Anillo sellado	A182 F304L
17	Anillo segmentado	ANSI 1045
18	Retén biela	A276 410
19	Pasador	AISI 304
20	Tuerca	AISI 304
21	Pasador	AISI 304
22	Arandela disco	A276 410

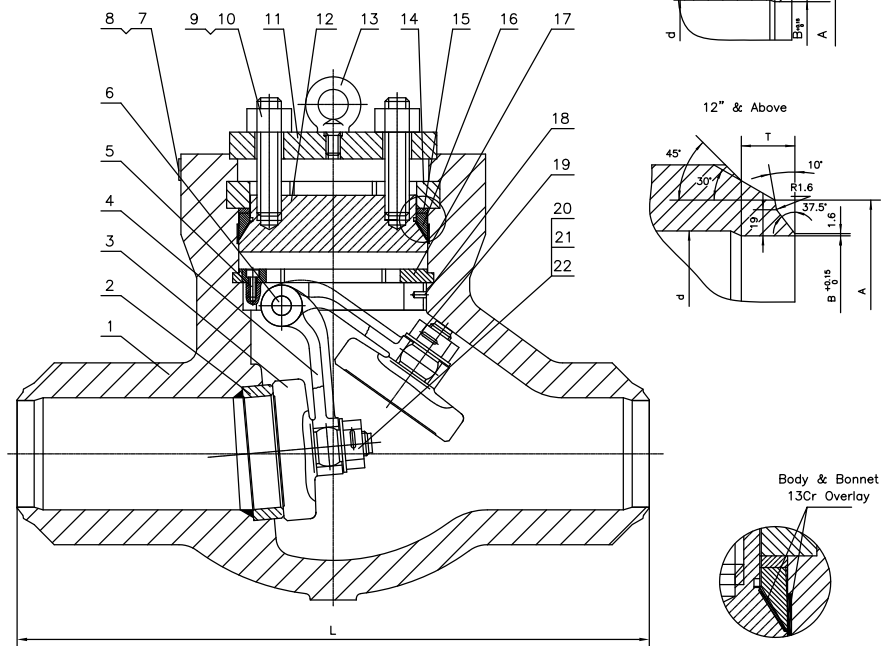

RETENCIÓN A CLAPETA WCB/F6 XU TRIM N° 8 - 900LBS BW

Código	DN	SCH	d	L	A	B	t
-	18"	120	400	1181	464	387	55
-	20"	120	445	1283	516	432	60

RETENCIÓN 1500LBS 2" - 6" DISEÑO PRESSURE SEAL

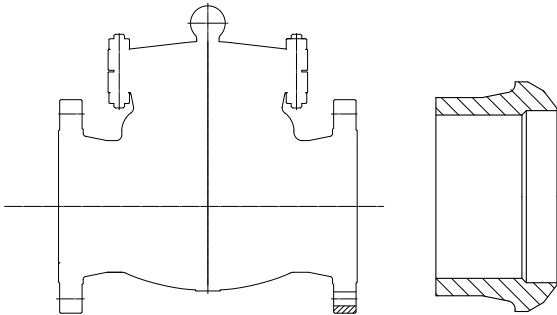

Retención Fig. SC15013XU		Clase: 1500LBS
VÁLVULA RETENCIÓN ACERO CARBONO 1500LBS SOLDAR		
Especificaciones		
Material	Acero carbono ASTM A216 WCB ¹	
Diseño	BS 1868	
Conexiones	Butt Welding según ASME B16.25	
Longitud	ASME B16.10	
Inspección y Pruebas	API 598	
NACE MR 01-75	Bajo demanda	
Aplicaciones	Refinerías, Petroquímica, Química, Metalurgia, Papel, Farmacéuticas...	
¹ Ver lista de materiales estándar		

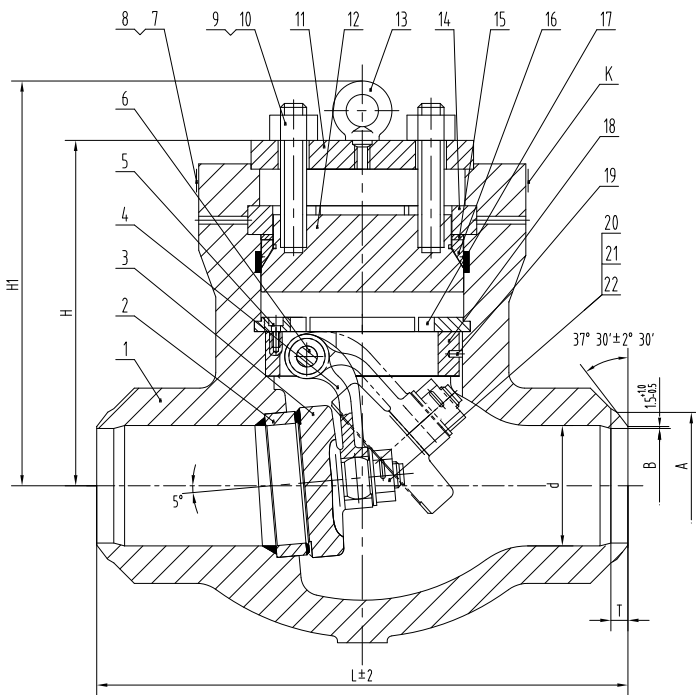

Componentes		
Pos.	Denominación	Material
1	Cuerpo	ASTM A216 WCB
2	Asiento	ASTM A105 +Stellite
3	Clapeta	ASTM A105 +ER410
4	Biela	ASTM A216 WCB
5	Tornillo	ASTM A276 304
6	Bulón	ASTM A276 410
7	Placa identificación	ASTM A240 321
8	Remache	ASTM A276 321
9	Espárrago	ASTM A193 B7
10	Tuerca	ASTM A194 2H
11	Tapa	ASTM A29 1025
12	Bonete	ASTM A29 1025
13	Tornillo	ASTM A29 1025
14	Anillo segmentado	ASTM A29 1045
15	Arandela	ASTM A36
16	Anillo sellado	ASTM A276 304
17	Anillo retén	ASTM A29 1025
18	Asiento biela	ASTM A216 WCB
19	Pasador	ASTM A276 410
20	Tuerca	ASTM A276 410
21	Arandela cierre	ASTM A276 410
22	Alambre acero	ASTM A276 304

FIG. SC15013XU - RETENCIÓN A CLAPETA WCB/F6 XU TRIM N° 8 - 1500LBS BW

Código	DN	d	L	H	H1	A	SCH80		SCH100		SCH120		SCH140		SCHXXS		SCH160		Peso (kg)
							T	B	T	B	T	B	T	B	T	B	T	B	
-	2"	48	216	198		62	9	49							17	38	14	43	25
-	3"	70	305	225		91	12	73.5							23	58.5	17	66.5	48
-	4"	92	406	264	308	117	13	97			17	92			26	80	21	87.5	90.4
-	6"	137	559	337	389	172	17	146.5			22	140			33	124.5	28	132	207.8

VÁLVULAS FUNDIDAS ANSI

RETENCIÓN 1500LBS 8" - 16" DISEÑO PRESSURE SEAL

Retención Fig. SC15013XU		Clase: 1500LBS
VÁLVULA RETENCIÓN ACERO CARBONO 1500LBS SOLDAR		
Especificaciones		
Material	Acero carbono ASTM A216 WCB ¹	
Diseño	BS 1868	
Conexiones	Butt Welding según ASME B16.25	
Longitud	ASME B16.10	
Inspección y Pruebas	API 598	
NACE MR 01-75	Bajo demanda	
Aplicaciones	Refinerías, Petroquímica, Química, Metalurgia, Papel, Farmacéuticas...	
¹ Ver lista de materiales estándar		

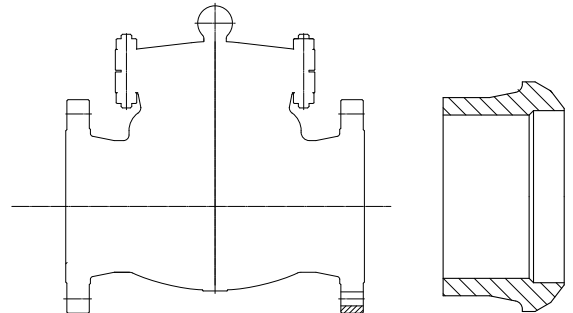

Componentes		
Pos.	Denominación	Material
1	Cuerpo	ASTM A216 WCB
2	Asiento	ASTM A105 +Stellite
3	Clapeta	ASTM A105 +ER410
4	Biela	ASTM A216 WCB
5	Tornillo	ASTM A276 304
6	Bulón	ASTM A276 410
7	Placa identificación	ASTM A240 321
8	Remache	ASTM A276 321
9	Espárrago	ASTM A193 B7
10	Tuerca	ASTM A194 2H
11	Tapa	ASTM A105
12	Bonete	ASTM A105
13	Tornillo	ASTM A29 1025
14	Anillo segmentado	ASTM A29 1045
15	Arandela	ASTM A36
16	Anillo sellado	ASTM A182 F304
17	Anillo	ASTM A105
18	Soprote biela	ASTM A216 WCB
19	Pasador	ASTM A276 410
20	Tuerca	ASTM A276 410
21	Arandela cierre	ASTM A276 410
22	Alambre acero	ASTM A276 304

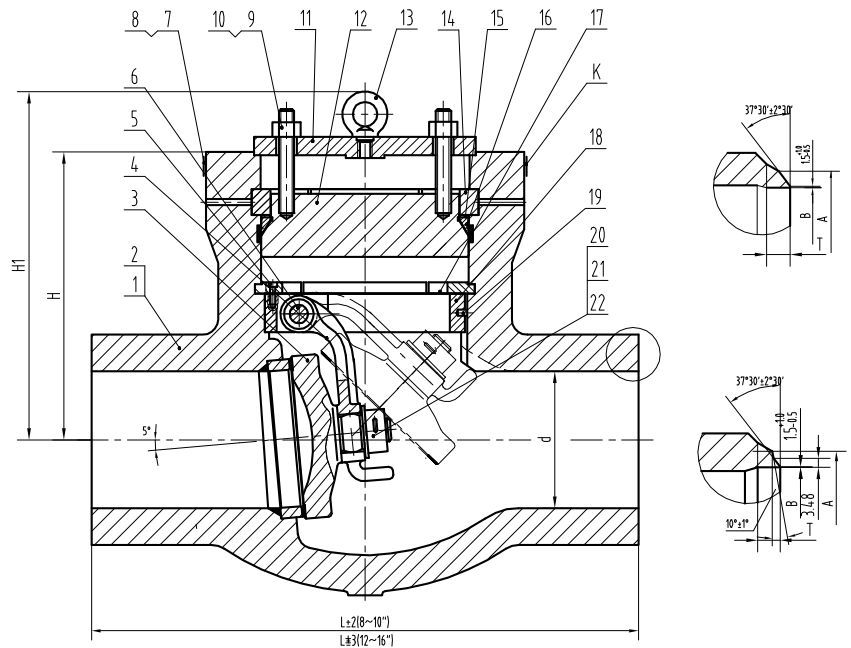
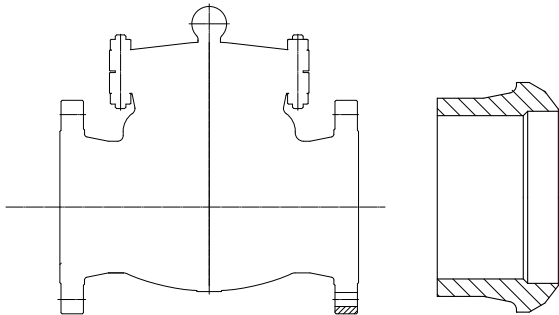

FIG. SC15013XU - RETENCIÓN A CLAPETA WCB/F6 XU TRIM N° 8 - 1500LBS BW

Código	DN	d	L	H	H1	A	SCH80		SCH100		SCH120		SCH140		SCHXXS		SCH160		Peso (kg)
							T	B	T	B	T	B	T	B	T	B	T	B	
-	8"	178	711	398	460	223	20	193.5	23	189.0	28	182.5	31	178.0	34	174.5	35	173.0	400.2
-	10"	222	864	471	559	278	23	243.0	28	236.5	33	230.0	39	222.0			43	216.0	700.1
-	12"	264	991	538	643	329	27	289.0	33	281.0	39	273.0	43	266.5			50	257.0	1101.2
-	14"	289	1067	584	708	362	29	317.5	36	308.0	42	300.0	48	292.0			54	284.0	1374.9
-	16"	330	1194	650	775	413	33	363.5	40	354.0	47	344.5	55	333.5			61	325.5	1988.9

RETENCIÓN 1500LBS 18" - 20" DISEÑO PRESSURE SEAL



Retención		Clase: 1500LBS
VÁLVULA RETENCIÓN ACERO CARBONO 1500LBS SOLDAR		
Especificaciones		
Material	Acero carbono ASTM A216 WCB ¹	
Diseño	BS 1868	
Conexiones	Butt Welding según ASME B16.25	
Longitud	ASME B16.10	
Inspección y Pruebas	API 598	
NACE MR 01-75	Bajo demanda	
Aplicaciones	Refinerías, Petroquímica, Química, Metalurgia, Papel, Farmacéuticas...	
¹ Ver lista de materiales estándar		

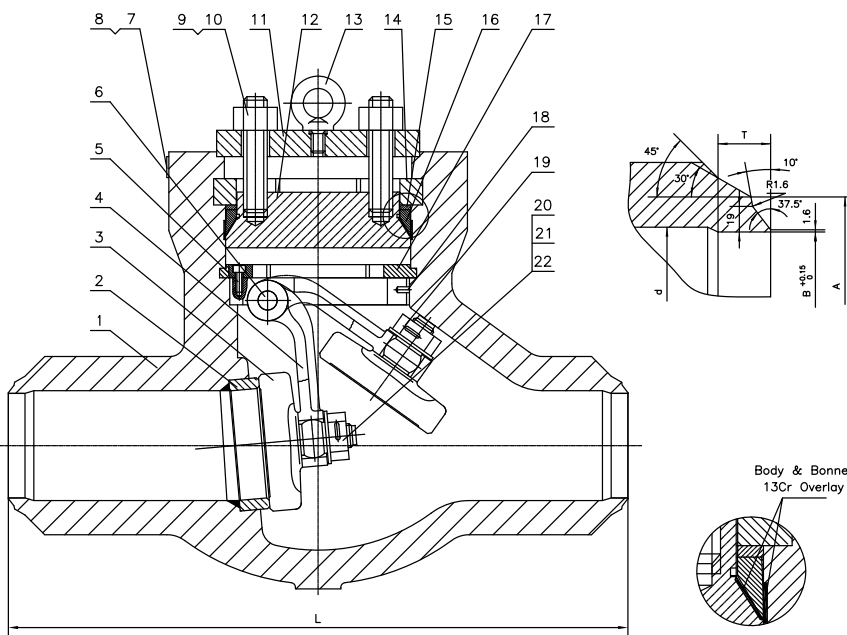

Componentes		
Pos.	Denominación	Material
1	Cuerpo	ASTM A216 WCB
2	Asiento	ASTM A105 +Stellite 6
3	Clapeta	A105 +Stellite 6
4	Biela	ASTM A216 WCB
5	Tornillo	Acero carbono
6	Bulón	A276 410
7	Remache	AISI 304
8	Placa identificación	AISI 304
9	Tuerca	A194 2H
10	Tornillo	A193 B7
11	Retén bonete	A105
12	Bonete	A105 +13% Cr
13	Argolla	ANSI 1025
14	Anillo segmentado	ANSI 1045
15	Anillo espaciador	ANSI 1045
16	Anillo Sellado	A182 F304L
17	Anillo segmentado	ANSI 1045
18	Retén biela	A276 410
19	Pasador	AISI 304
20	Tuerca	AISI 304
21	Pasador partido	AISI 304
22	Arandela	A276 410

RETENCIÓN A CLAPETA WCB/F6 XU TRIM N° 8 - 1500LBS BW

Código	DN	SCH	d	L	A	B	t
-	18"	160	371	1346	464	367	70
-	20"	160	416	1473	516	408	75

VÁLVULAS FUNDIDAS ANSI

RETENCIÓN 2500LBS 6" - 12" DISEÑO PRESSURE SEAL

Retención	Clase: 2500LBS
VÁLVULA RETENCIÓN ACERO CARBONO 2500LBS SOLDAR	
Especificaciones	
Material	Acero carbono ASTM A216 WCB ¹
Diseño	BS 1868
Conexiones	Butt Welding según ASME B16.25
Longitud	ASME B16.10
Inspección y Pruebas	API 598
NACE MR 01-75	Bajo demanda
Aplicaciones	Refinerías, Petroquímica, Química, Metalurgia, Papel, Farmacéuticas...
¹ Ver lista de materiales estándar	

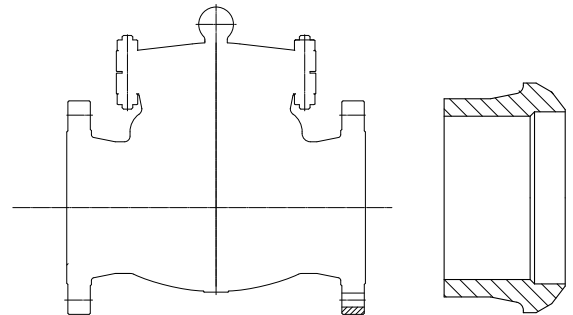

Componentes		
Pos.	Denominación	Material
1	Cuerpo	ASTM A216 WCB
2	Asiento	ASTM A105 +Stellite 6
3	Clapeta	A105 +Stellite 6
4	Biela	ASTM A216 WCB
5	Tornillo	Acero carbono
6	Bulón	A276 410
7	Remache	AISI 304
8	Placa identificación	AISI 304
9	Tuerca	A194 2H
10	Tornillo	A193 B7
11	Retén bonete	A105
12	Bonete	A105 +13% Cr
13	Argolla	ANSI 1025
14	Anillo segmentado	ANSI 1045
15	Anillo espaciador	ANSI 1045
16	Anillo Sellado	A182 F304L
17	Anillo segmentado	ANSI 1045
18	Retén biela	A276 410
19	Pasador	AISI 304
20	Tuerca	AISI 304
21	Pasador partido	AISI 304
22	Arandela	A276 410

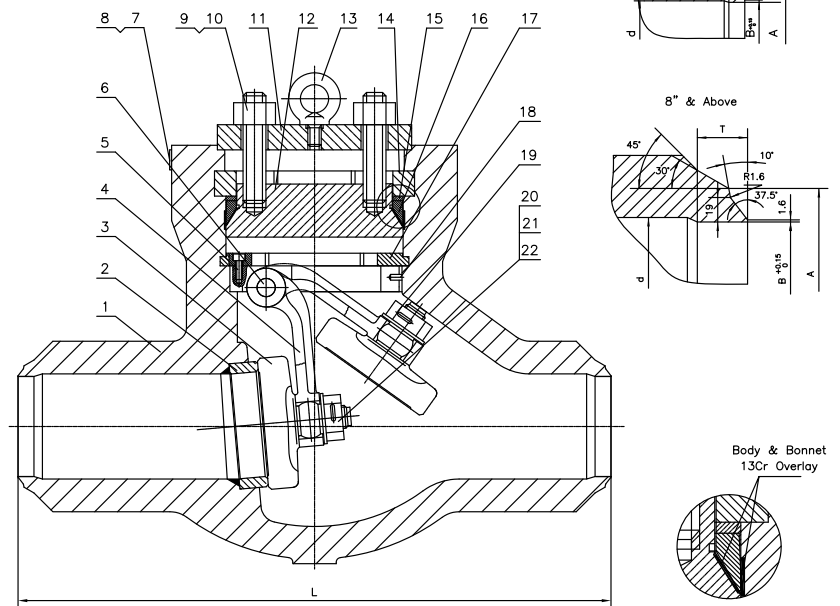

RETENCIÓN A CLAPETA WCB/F6 XU TRIM N° 8 - 2500LBS BW

Código	DN	SCH	d	L	A	B	t
-	6"	160	111	610	172	132	28
-	8"	160	146	762	223	173	35
-	10"	160	184	914	278	216	45
-	12"	160	219	1041	329	257	50

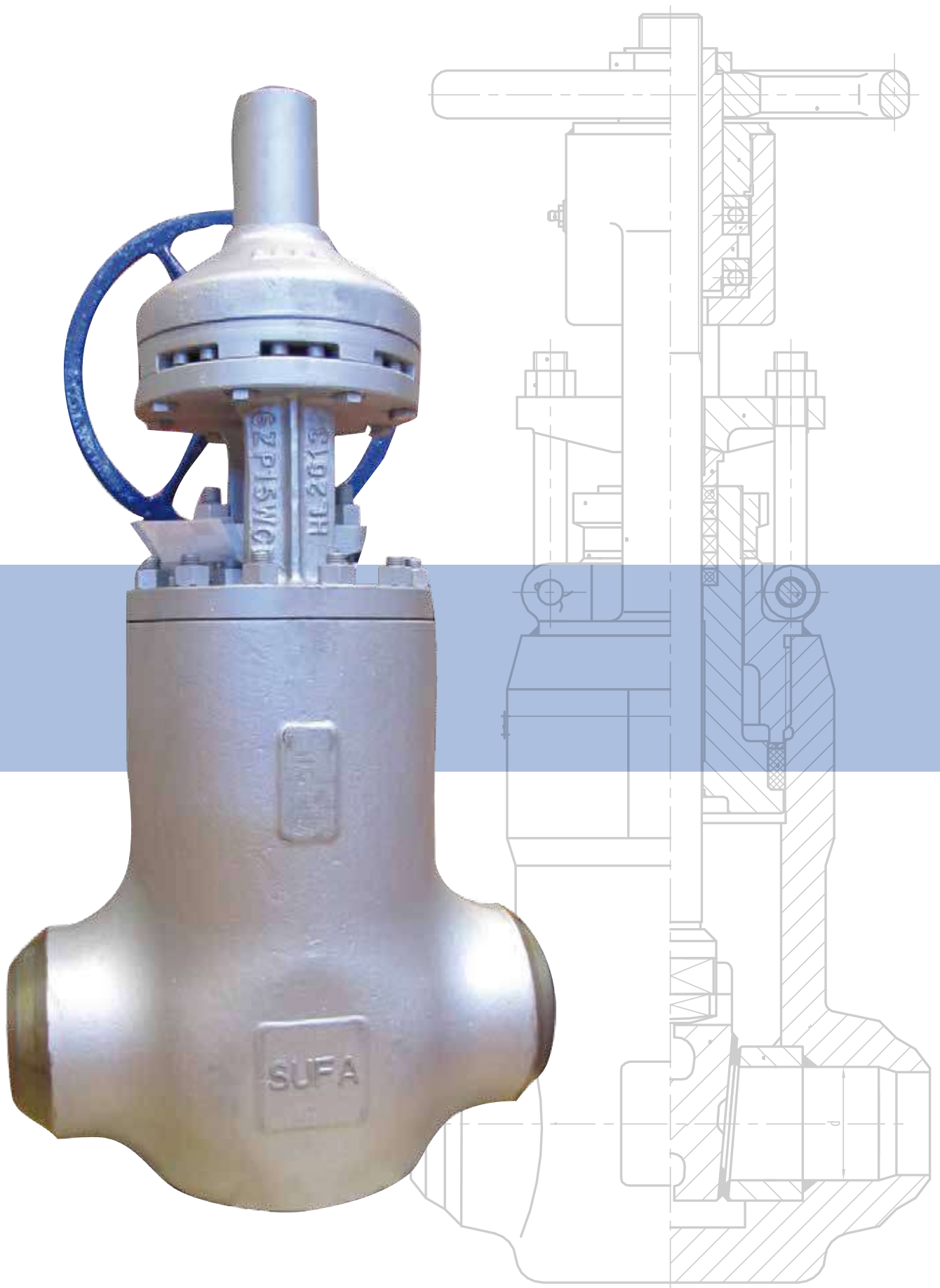



VÁLVULAS FORJADAS PRESSURE SEAL



COMPUERTA • GLOBO • RETENCIÓN VÁLVULAS FORJADAS PRESSURE SEAL

- » **FABRICACIÓN:** Nuevo diseño de válvulas forjadas para **Alta Presión**, basado en tecnología nuclear
- » **APLICACIONES:** Plantas de generación de Energía (Térmica y Nuclear), Servicio de Hidrógeno, Petroquímica, Refinerías, Ciclos combinados, Cogeneración, etc...
- » **TIPOS:** Compuerta, Globo paso recto, paso en 'Y', Retención
- » **RATING:** 900, 1500, 2500LBS
- » **MATERIALES:** Acero carbono A105, Acero aleado ASTM A182 F11 / F22 / F91, Acero inoxidable ASTM A182 F304 / F316 / F321
- » **EXTREMOS:** BW Según ASME B16.25



ACTUAL GAMA DE FABRICACIÓN CON MODELOS DISPONIBLES¹

TIPO DE VÁLVULA	900 LBS	1500 LBS	2500 LBS
COMPUERTA	2" - 6"	2" - 6"	2" - 4"
GLOBO	1/2" - 2"	1/2" - 2"	1/2" - 2"
GLOBO 'Y'	1/2" - 2" 3"	1/2" - 2" 3"	1/2" - 2" 3"
RETENCIÓN CLAPETA (4" en desarrollo)	2" - 3" 6"	2" - 3" 6"	2" - 3" N/A

¹ Nuevos modelos de fabricación se irán incorporando en función de la demanda del mercado

VÁLVULAS FORJADAS PRESSURE SEAL

COMPUERTA FORJADA 900LBS 2" - 4" BRIDAS PRESSURE SEAL

COMPUERTA FORJADA PRESSURE SEAL		Clase: 900LBS
VÁLVULA COMPUERTA ACERO CARBONO 900LBS BRIDAS PRESSURE SEAL		
Especificaciones		
Material	Acero carbono ASTM A105	
Diseño	API 600	
Conexiones	Butt Welding según ASME B16.25	
Longitud	ASME B16.10	
Inspección y Pruebas	API 598	
NACE MR 01-75	Bajo demanda	
Aplicaciones	Refinerías, Petroquímica, Química, Metalurgia, Papel, Farmacéuticas...	
¹Ver lista de materiales estándar		

Componentes		
Pos.	Denominación	Material
1	Cuerpo	ASTM A105
2	Asientos	ASTM A105 +Stellite
3	Cuña	ASTM A216 WCB +Stellite
4	Husillo	ASTM A182 F316
5	Caja prensaestopas	ASTM A105 +321
6	Anillo de sellado	Grafito / Acero inoxidable
7	Pasador	ASTM A29 1035
8	Empaquetadura	Grafito flexible
9	Empaquetadura	Grafito / Acero inoxidable
10	Casquillo prensaestopas	ASTM A276 316
11	Brida prensaestopas	ASTM A216 WCB
12	Tuerca husillo	ASTM A439 D-2
13	Cojinete	
14	Tuerca retén	ASTM A29 1035
15	Volante	ASTM A536 60-40-18
16	Tuerca volante	ASTM A29 1035
17	Engrasador	ASTM A36
18	Tornillo	ASTM A193 B7
19	Tuerca	ASTM A194 2H
20	Tuerca	ASTM A29 1045
21	Puente	ASTM A216 WCB
22	Junta	ASTM A36
23	Pasador partido	ASTM A36
24	Placa identificación	ASTM A240 321
25	Remache	ASTM A276 321
26	Junta	ASTM A36

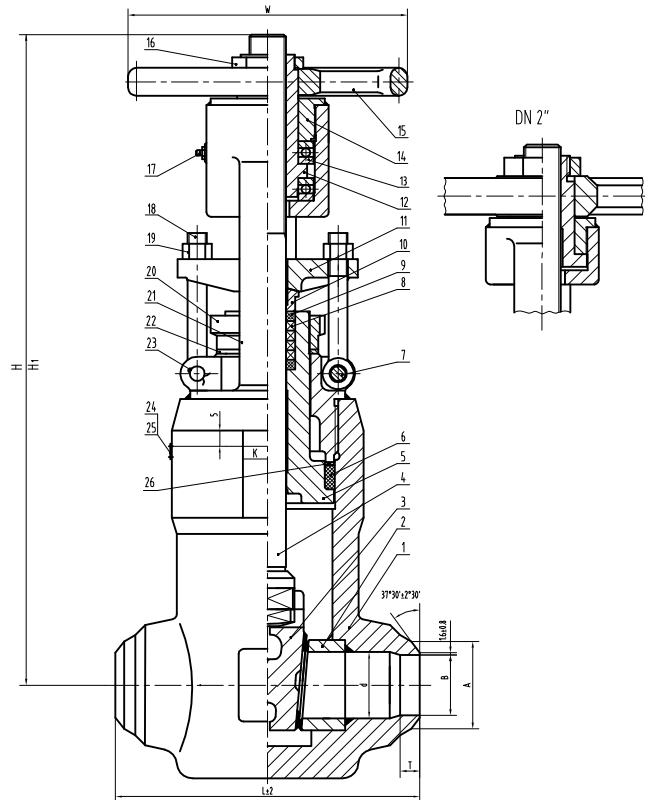

COMPUERTA A105/F6 U - 900LBS BW¹

Código	DN	d	SCH80			SCH120			SCH160			L	W	H1	H	Peso (kg)
			A	B	T	A	B	T	A	B	T					
-	2"	47	60.3	49	9				60.3	43	14	216	300	438	499	42.44
-	3"	73	88.9	73.5	12				91.0	66.5	17	305	310			86.5
-	4"	98	114.3	97.0	13	117	92	17	117.0	87.5	21	356	460	670	790	137.7

¹ Nota: Esta ficha técnica y las siguientes representan sólo una pequeña muestra de la amplia gama de fabricación de Válvulas Forjadas Pressure Seal. Si necesita más información, póngase en contacto con nuestro Departamento técnico.

COMPUERTA FORJADA 1500LBS 2" - 4" PRESSURE SEAL

COMPUERTA FORJADA PRESSURE SEAL		Clase: 1500LBS
VÁLVULA COMPUERTA ACERO CARBONO 1500LBS BRIDAS PRESSURE SEAL		
Especificaciones		
Material	Acero carbono ASTM A105	
Diseño	API 600	
Conexiones	Butt Welding según ASME B16.25	
Longitud	ASME B16.10	
Inspección y Pruebas	API 598	
NACE MR 01-75	Bajo demanda	
Aplicaciones	Refinerías, Petroquímica, Química, Metalurgia, Papel, Farmacéuticas...	
¹Ver lista de materiales estándar		

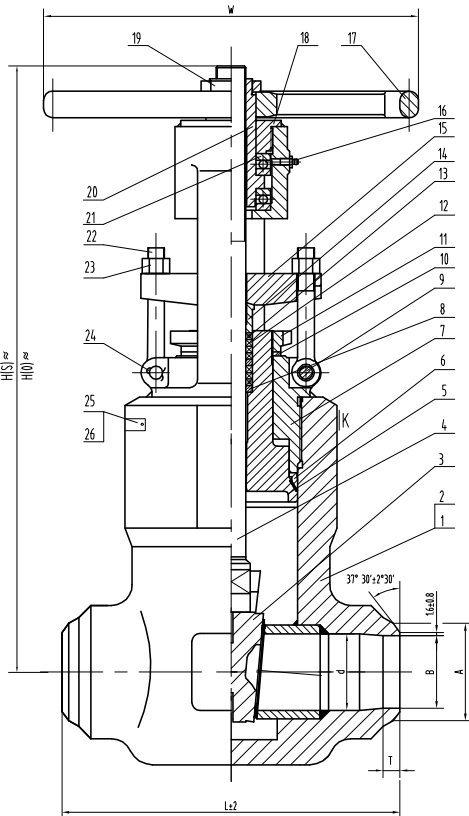

Componentes		
Pos.	Denominación	Material
1	Cuerpo	ASTM A105
2	Asientos	ASTM A105 +Stellite
3	Cuña	ASTM A216 WCB +Stellite
4	Husillo	ASTM A182 F6 Cl.2
5	Caja prensaestopas	ASTM A105
6	Anillo de sellado	ASTM A182 F304
7	Puente	ASTM A216 WCB
8	Arandela empaquetadura	ASTM A276 410
9	Pasador	ASTM A29 1035
10	Arandela	ASTM A36
11	Tuerca	ASTM A2 1045
12	Empaquetadura	Grafito flexible
13	Empaquetadura	Grafito / Acero inoxidable
14	Casquillo prensaestopas	ASTM A276 410
15	Brida prensaestopas	ASTM A216 WCB
16	Engrasador	ASTM A36
17	Volante	ASTM A536 60-40-18
18	Tuerca	ASTM A29 1035
19	Tuerca	ASTM A29 1035
20	Tuerca husillo	ASTM A439 D-2
21	Cojinete	
22	Tornillo	ASTM A194 B7
23	Tuerca	ASTM A194 2H
24	Pasador partido	ASTM A36
25	Placa identificación	ASTM A240 321
26	Remache	ASTM A276 321

COMPUERTA A105/F6 U - 1500LBS BW

Código	DN	d	A	SCH 80		SCH 120		SCH 160		SCH XXS		L	W	H(S)	H(O)	Peso (kg)
				B	T	B	T	B	T	B	T					
-	2"	47	60.3	49	9			43	14	38	17	216	300	505	565	68.7
-	3"	70	88.9	73.5	12			66.5	17	58.5	23	305	350	622	705	118.3
-	4"	92	114.3	97	13	92	17	87.5	21	80	26	406	450	704	810	210.8

VÁLVULAS FORJADAS PRESSURE SEAL

COMPUERTA FORJADA 1500LBS 6" PRESSURE SEAL CON REDUCTOR

COMPUERTA FORJADA PRESSURE SEAL		Clase: 1500LBS
VÁLVULA COMPUERTA ACERO CARBONO PRESSURE SEAL		
Especificaciones		
Material	Acero carbono ASTM A105	
Diseño	API 600	
Conexiones	Butt Welding según ASME B16.25	
Longitud	ASME B16.10	
Inspección y Pruebas	API 598	
NACE MR 01-75	Bajo demanda	
Aplicaciones	Refinerías, Petroquímica, Química, Metalurgia, Papel, Farmacéuticas...	
*Ver lista de materiales estándar		

Componentes		
Pos.	Denominación	Material
1	Cuerpo	ASTM A105
2	Asientos	ASTM A105 +Stellite 6
3	Cuña	ASTM A216 WCB +Stellite 6
4	Husillo	ASTM A182 F6a Cl.2
5	Caja prensaestopas	ASTM A105
6	Anillo sellado	ASTM A182 F304
7	Empaquetadura	Grafito flexible
8	Empaquetadura	Grafito / Acero inoxidable
9	Casquillo prensaestopas	ASTM A276 410
10	Brida prensaestopas	ASTM A216 WCB
11	Tuerca husillo	ASTM A439 D-2
12	Tornillo	ASTM A193 B7
13	Espárrago	ASTM A193 B7
14	Tuerca	ASTM A194 2H
15	Espárrago	ASTM A193 B7
16	Tuerca	ASTM A194 2H
17	Espárrago	ASTM A193 B7
18	Tuerca	ASTM A194 2H
19	Anillo partido	ASTM A29 1045
20	Placa identificación	ASTM A240 321
21	Riemache	ASTM A276 321
22	Puente	ASTM A216 WCB
23	Junta	ASTM A36
24	Pletina empaquetadura	ASTM A276 410
25	Reductor manual	

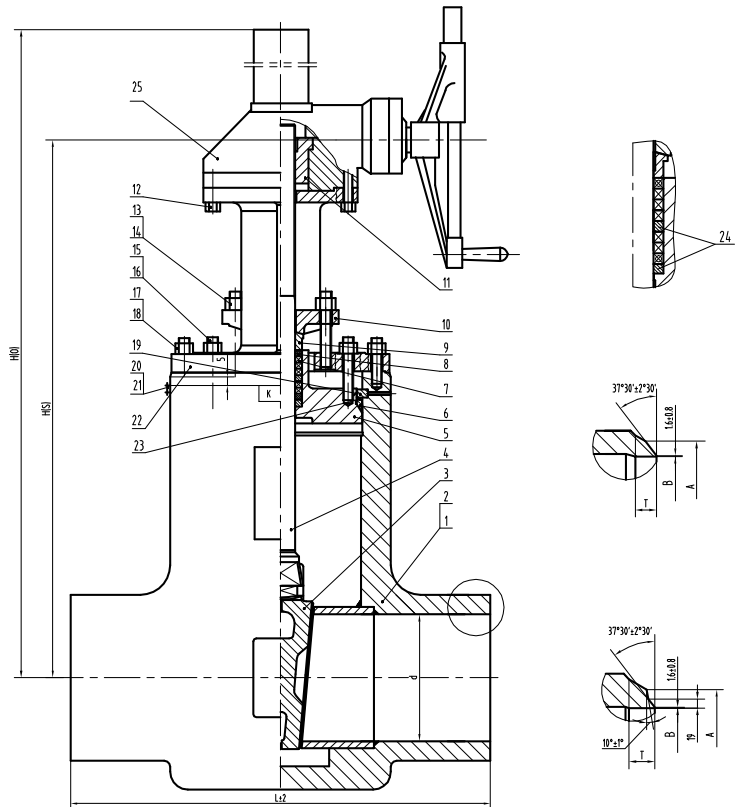

COMPUERTA A105/F6 U - 1500LBS BW

Código	DN	d	A	SCH 80		SCH 120		SCH 160		SCH XXS		L	H(O)	H(S)	Peso (kg)
				B	T	B	T	B	T	B	T				
-	6"	137	168.3	146.5	17	140	22	132	18	124.5	33	559	947	742	489.8

GLOBO FORJADA 2500LBS 4" PRESSURE SEAL

GLOBO FORJADA PRESSURE SEAL		Clase: 2500LBS
VÁLVULA GLOBO ACERO CARBONO 2500LBS BRIDAS PRESSURE SEAL		
Especificaciones		
Material	Acero carbono ASTM A105	
Diseño	BS 1873	
Conexiones	Butt Welding según ASME B16.25	
Longitud	ASME B16.10	
Inspección y Pruebas	API 598	
NACE MR 01-75	Bajo demanda	
Aplicaciones	Refinerías, Petroquímica, Química, Metalurgia, Papel, Farmacéuticas...	
¹ Ver lista de materiales estándar		

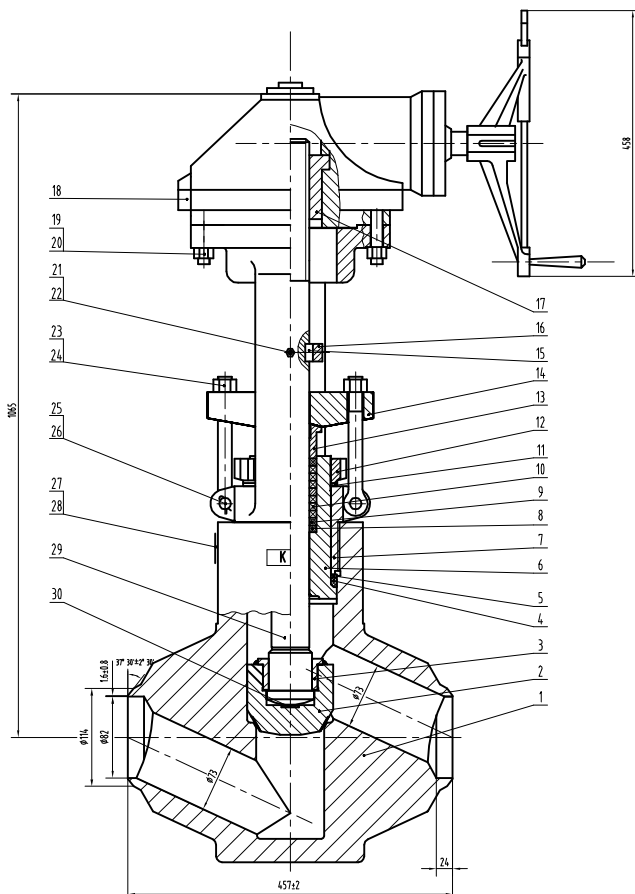

Componentes		
Pos.	Denominación	Material
1	Cuerpo	ASTM A105
2	Obturador	ASTM A105 +Stellite 6
3	Tuerca obturador	ASTM A182 F6 Cl.1
4	Anillo sellado	Grafito / Acero inoxidable
5	Arandela	ASTM A36
6	Caja prensaestopas	ASTM A105
7	Puente	ASTM A216 WCB
8	Anillo empaquetadura	ASTM A276 410
9	Empaquetadura	Grafito / Acero inoxidable
10	Empaquetadura	Grafito flexible
11	Anillo	ASTM A36
12	Tuerca bloqueo	ASTM A29 1045
13	Casquillo prensaestopas	ASTM A276 410
14	Brida prensaestopas	ASTM A216 WCB
15	Bloqueo de Guía	ASTM A29 1045
16	Tornillo	ASTM A29 1045
17	Tuerca husillo	
18	Reductor manual	
19	Tornillo	ASTM A193 B7
20	Tuerca	ASTM A194 2H
21	Tuerca	ASTM A29 1035
22	Tuerca	ASTM A29 1045
23	Tornillo	ASTM A193 B7
24	Tuerca	ASTM A29 1045
25	Pasador bulón	ASTM A29 1035
26	Pasador	ASTM A36
27	Placa identificación	ASTM A240 321
28	Remache	ASTM A276 321
29	Husillo	ASTM A182 F6a Cl.3
30	Pletina de empuje	ASTM A276 420

VÁLVULAS FORJADAS PRESSURE SEAL

RETENCIÓN CLAPETA FORJADA 1500LBS 2" - 6" PRESSURE SEAL

RETENCIÓN CLAPETA FORJADA PRESSURE SEAL		Clase: 1500LBS
VÁLVULA RETENCIÓN CLAPETA ACERO CARBONO PRESSURE SEAL		
Especificaciones		
Material	Acero carbono ASTM A105	
Diseño	BS 1868	
Conexiones	Butt Welding según ASME B16.25	
Longitud	ASME B16.10	
Inspección y Pruebas	API 598	
NACE MR 01-75	Bajo demanda	
Aplicaciones	Refinerías, Petroquímica, Química, Metalurgia, Papel, Farmacéuticas...	
*Ver lista de materiales estándar		

Componentes		
Pos.	Denominación	Material
1	Cuerpo	ASTM A105
2	Asientos	ASTM A105 +Stellite 6
3	Clapeta	ASTM A105 +Stellite 6 (2" - 4")
4		AASTM A216 WCB +Stellite 6 (6")
5	Bulón	ASTM A216 WCB
6	Pasador biela	ASTM A276 410
7	Placa identificación	ASTM A240 321
8	Remache	ASTM A276 321
9	Espárrago	ASTM A193 B7M
10	Tuerca	ASTM A194 2HM
11	Pletina tapa	ASTM A105
12	Tapa	ASTM A105
13	Argolla	ASTM A29 1025
14	Anillo partido	ASTM A105
15	Arandela	ASTM A36
16	Anillo de sellado	Grafito / Acero inoxidable
17	Anillo	ASTM A105
18	Asiento biela	ASTM A216 WCB
19	Pasador	ASTM A276 410
20	Tuerca	ASTM A276 410
21	Arandela	ASTM A276 410
22	Pasador	ASTM A276 304

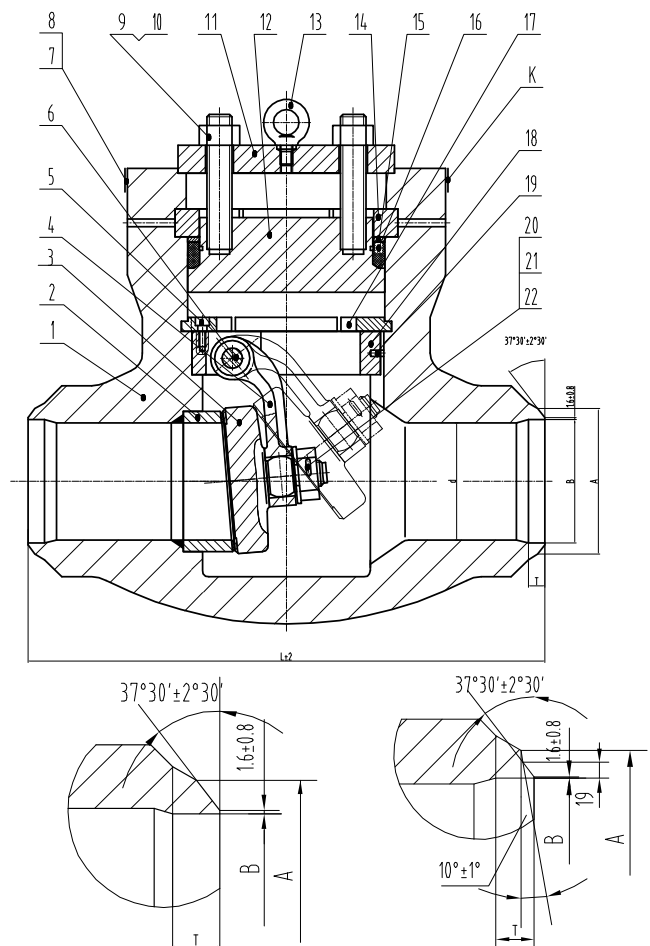

RETENCIÓN CLAPETA A105/F6 U - 1500LBS BW

Código	DN	d	L	A	SCH 80		SCH 100		SCH 120		SCH 140		SCH XXS		SCH 160		Peso (kg)
					T	B	T	B	T	B	T	B	T	B			
-	2"	48	216	60.3	8.3	4.9	9.5	48	11	46			16.5	38	13	43	23
-	3"	70	305	91	12	73.5							23	58.5	17	66.5	37.8
-	4"	92	406	117	13	97			17	92			26	80	21	87.5	63
-	6"	137	559	172	17	146.5			22	140			33	124	28	132	138

GLOBO 'Y' FORJADA 1500LBS 3" PRESSURE SEAL

GLOBO 'Y' FORJADA PRESSURE SEAL		Clase: 1500LBS
VÁLVULA GLOBO 'Y' ACERO CARBONO 1500LBS BRIDAS PRESSURE SEAL		
Especificaciones		
Material	Acero carbono ASTM A105	
Diseño	BS 1873	
Conexiones	Butt Welding según ASME B16.25	
Longitud	ASME B16.10	
Inspección y Pruebas	API 598	
NACE MR 01-75	Bajo demanda	
Aplicaciones	Refinerías, Petroquímica, Química, Metalurgia, Papel, Farmacéuticas...	
¹ Ver lista de materiales estándar		

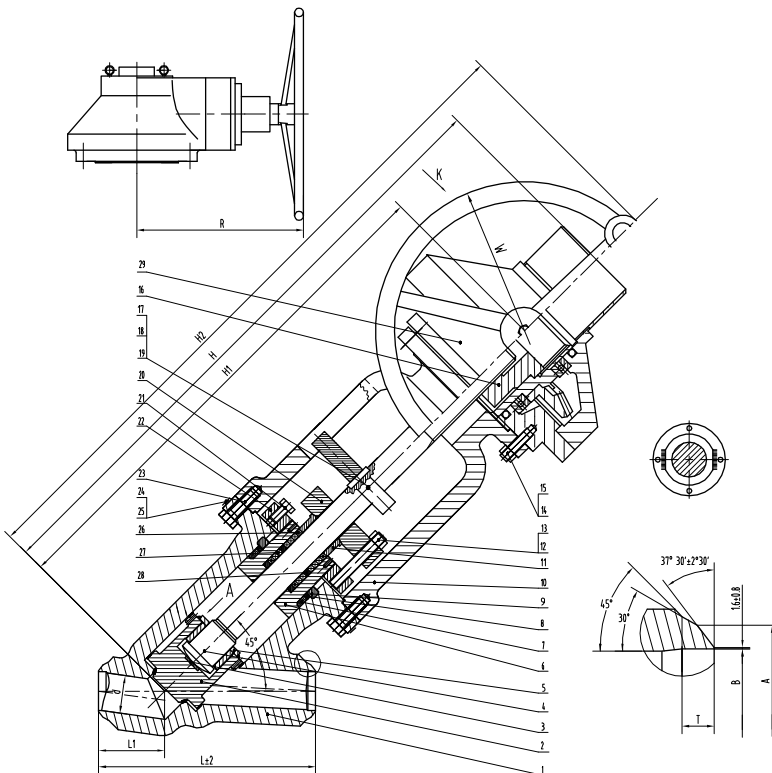

Componentes		
Pos.	Denominación	Material
1	Cuerpo	ASTM A105
2	Obturador	ASTM A105 +Stellite 6
3	Pletina empuje	ASTM A276 420
4	Husillo	ASTM A182 F6a Cl.2
5	Tuerca obturador	ASTM A182 F6a Cl.1
6	Caja prensaestopas	ASTM A105 +Cr13
7	Anillo	
8	Anillo	ASTM A29
9	Anillo	ASTM A29 1045
10	Puente	ASTM A216 WCB
11	Casquillo prensaestopas	ASTM A276 410
12	Espárrago	ASTM A193 B7
13	Tuerca	ASTM A194 2H
14	Espárrago	ASTM A193 B7
15	Tuerca	ASTM A194 2H
16	Tuerca husillo	
17	Pletina guía	ASTM A29 1045
18	Tuerca	ASTM A29 1035
19	Llave	ASTM A29 1045
20	Brida prensaestopas	ASTM A216 WCB
21	Tornillo	ASTM A193 B7M
22	Placa de cojinetes	ASTM A29 1045
23	Tornillo	ASTM A193 B7
24	Placa identificación	ASTM A240 321
25	Remache	ASTM A276 321
26	Empaquetadura	Grafito / Acero inoxidable
27	Empaquetadura	Grafito flexible
28	Arandela	ASTM A276 410
29	Reductor manual	

GLOBO 'Y' A105/F6 U - 1500LBS BW

Código	DN	d	A	SCH 80		SCH 160		SCH XXS		L1	L	W	R	H1	H2	H(S)	H(O)	Peso (kg)
				B	T	B	T	B	T									
-	3"	65	88.9	73.5	12	66.6	17	58.5	23	112	368	610	318	94.4	827	820	937	213.3



VÁLVULAS DE FUELLE

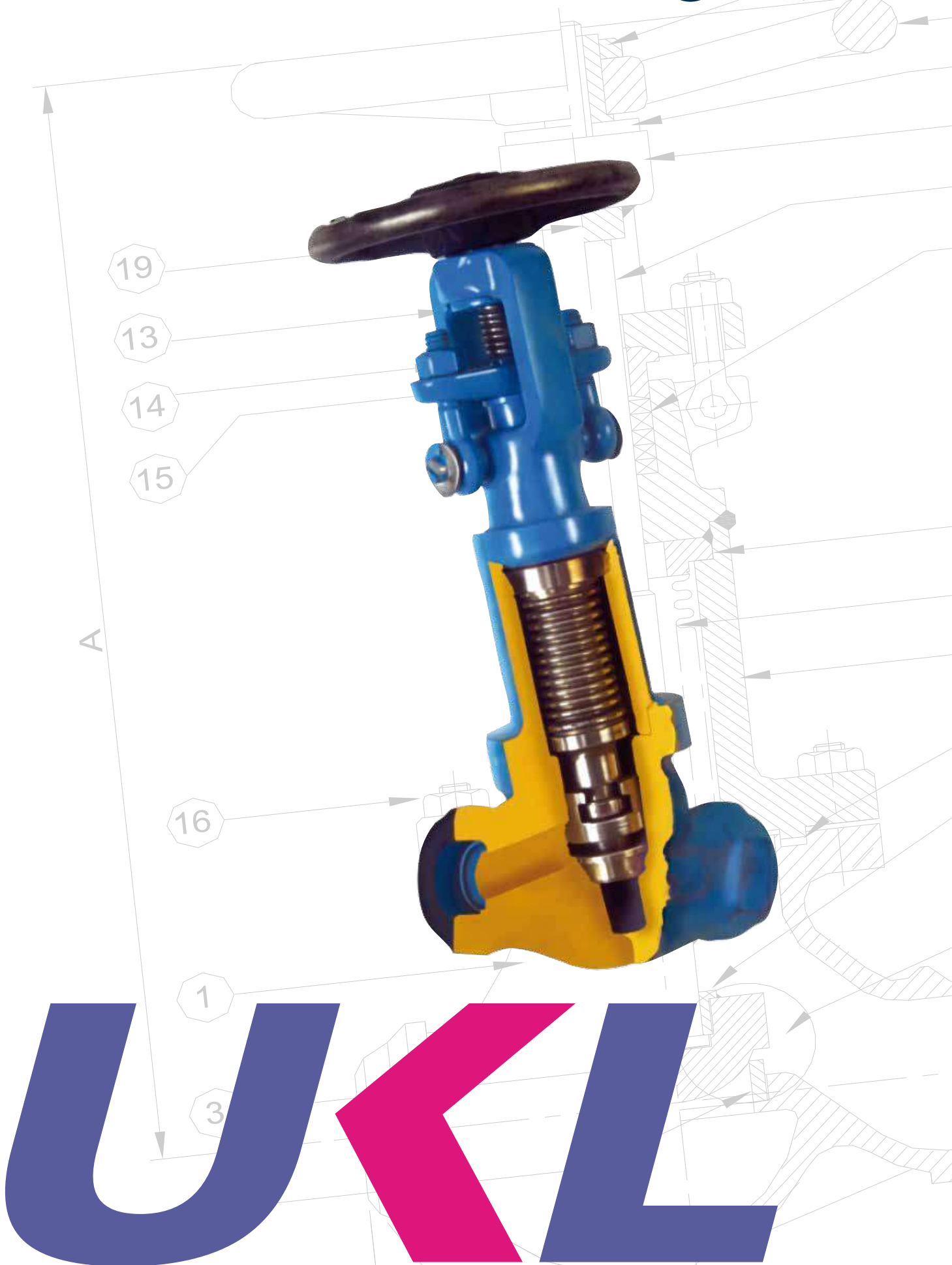

Bellows seal valves



VÁLVULAS DE FUELLE

Diversos estudios efectuados sobre fugas en la industria de proceso han demostrado que el 75 % de los casos de fuga causan:

1. Contaminación atmosférica
2. Pérdidas en la producción
3. Problemas en el proceso y
4. La pérdida de Energía

En la línea con la importancia que en la actualidad se da a la prevención de la contaminación del medio ambiente y el ahorro de energía, se hace absolutamente imprescindible eliminar por completo este tipo de fugas.

Además, las condiciones actuales del mercado demandan cada vez más mejoras en los métodos de proceso y la reducción de costes para asegurar la producción. A pesar de la estricta selección, instalación y cuidado preventivo periódico que se da en las válvulas convencionales, es imposible erradicar del todo las fugas. Sabemos que, a pesar de que inicialmente, el funcionamiento de la instalación es correcto, las líneas están abocadas a tener fugas en algún momento a través de la empaquetadura después de un número determinado de operaciones. La única solución para este problema viene dado al seleccionar Válvulas de Fuelle. De ahí que este tipo de válvulas se use cada día más.

Las válvulas de fuelle UKL están diseñadas y fabricadas de acuerdo con estándares internacionales tales como ANSI, API, ASTM, BS, DIN, MSS, etc. También fabricamos válvulas a medida basándonos en las especificaciones del cliente y el feed back de sus usuarios habituales.

VÁLVULAS DE GLOBO

Tamaño	DN-15 a 400
Rating	Clase 150 a 2500
Norma de Diseño	ANSI, API, ASME, BS, DIN, MSS
Conexiones	Socket Weld, Roscadas, Bridas o Butt Weld

VÁLVULAS DE COMPUERTA

Tamaño	DN-15 a 600
Rating	Clase 150 a 2500
Norma de Diseño	ANSI, BS, etc.
Conexiones	Socket Weld, Roscadas, Bridas o Butt Weld

MATERIALES DE CONSTRUCCIÓN

Acero carbono	ASTM A105, ASTM A216 WCB, WC6, WC9, etc.
Acero calmado	LF2, ASTM A352 LCB, LCC, etc.
Acero inoxidable	A182 F304, F316, A351 Gr. CF8/CF8M/CF3/CF3M, etc.
Fuelle	AISI 321, 316, 316L, 316Ti, Inconel, Hastelloy C-276, Monel, etc.
Accionamiento	Volante, Reductor manual, Neumático, Eléctrico, etc.

VÁLVULAS PARA APLICACIONES ESPECIALES

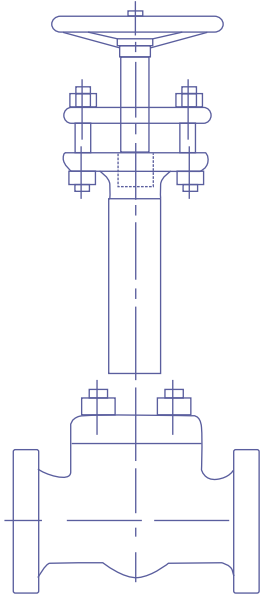

VÁLVULA SERV. CRIOGÉNICO

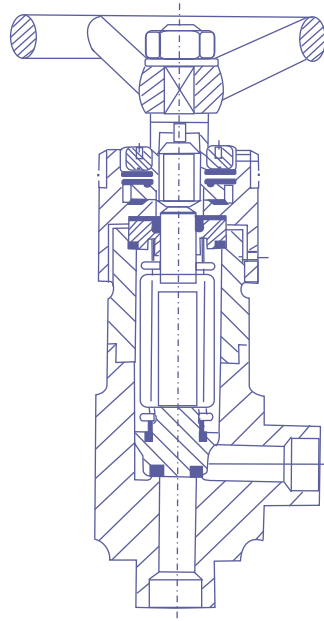

VÁLVULA ANGULAR

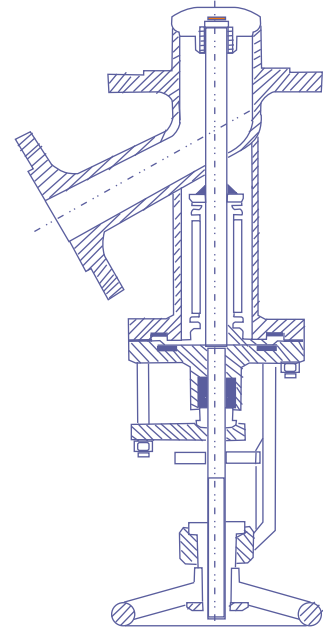

VÁLVULA TOMA DE MUESTRAS

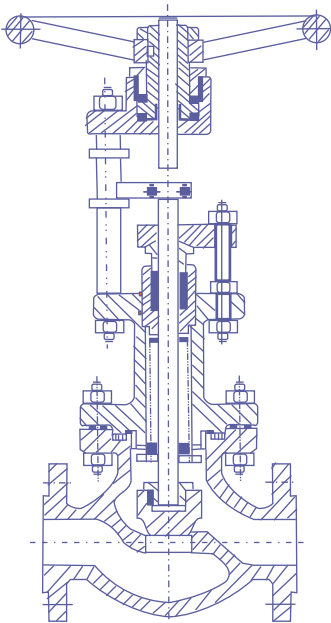

VÁLVULA EUROCHLOR

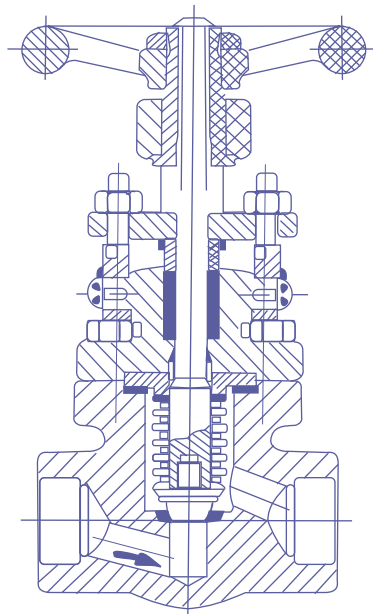

VÁLVULA PARA VAPOR

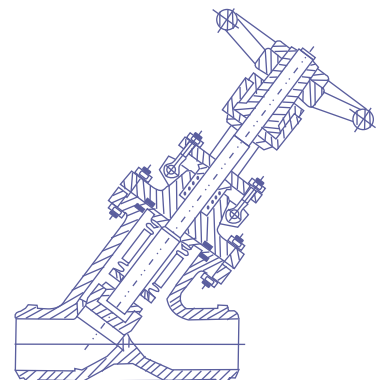

VÁLVULA GLOBO 'Y'

VÁLVULAS DE FUELLE

COMPUERTA TIPO FUELLE 150/300LBS

UKL Compuerta tipo Fuelle		Clase: 150/300LBS
VÁLVULA COMPUERTA TIPO FUELLE		
Especificaciones		
Material	Acero carbono ASTM A105 o A182 F304 / F316*	
Diseño	BS 5352 / API 602 (Paso estándar)	
Conexiones	SW según ANSI B16.11 o BW según B16.25 o NPT según B1.20.1	
Longitud	Estándar del fabricante	
Inspección y Pruebas	API 598	
Diseño DIN	Bajo demanda	
Aplicaciones	Therminol-66, Dowtherm vapour, Hot Oil/HTM, Vacuum, Steam, Ammonia, Refrigerant, Phosgene, Chlorine, Hydrogen, Oxygen, CO, Hazardous and Poisonous liquids gases, Radioactive substances...	

* Otros materiales del cuerpo bajo demanda

Pos.	Pieza	Componentes	
		Acero carbono	Acero inoxidable
1	Cuerpo	ASTM A105	A182 F304 / F316
2	Tapa	ASTM A105	A182 F304 / F316
3	Obturador	AISI 410	AISI 304 / 316
4	Asiento	AISI 410	AISI 304 / 316
5	Husillo	AISI 410	AISI 304 / 316
6	Fuelle	AISI 316Ti	AISI 316Ti
7	Empaquetadura	Grafito	PTFE
8	Tornillo ojo y tuerca	Acero carbono	AISI 304 / 316
9	Casquillo	AISI 410	AISI 304 / 316
10	Brida prensaestopas	Acero carb. / A105	AISI 304 / 316
11	Puente	Ni-Resist	Ni-Resist
12	Volante	Hierro / Acero carb.	Hierro / Acero carb.
13	Bridas	A105	Acero inoxidable
14	Cilindro	A106 Gr. B	Acero inoxidable
15	Collarín fuelle	AISI 316	AISI 316

PRESIÓN / TEMPERATURA

Presión prueba	150LBS	300LBS
Cuerpo (hidráulica)	32 kg/cm ²	79 kg/cm ²
Asiento (hidráulica)	23 kg/cm ²	58 kg/cm ²
Asiento (neumática)	7 kg/cm ²	7 kg/cm ²

150LBS

Tamaño (mm)	15	20	25	40
Longitud total	108	118	127	165
Ø brida	89	98.5	108	127
Espesor brida	11	13	14.5	17.5
Ø R.F.	35	43	51	73
Espesor R.F.	2	2	2	2
Diámetro centro taladros	60.3	70	79.4	98.4
Número de taladros / Ø taladro	4/16	4/16	4/16	4/16

300LBS

Tamaño (mm)	15	20	25	40
Longitud total	153	178	203	229
Ø brida	96	117.5	124	156
Espesor brida	14.3	16	17.5	21
Ø R.F.	35	43	51	73
Espesor R.F.	2	2	2	2
Diámetro centro taladros	66.7	82.6	89	114.3
Número de taladros / Ø taladro	4/16	4/19	4/19	4/22

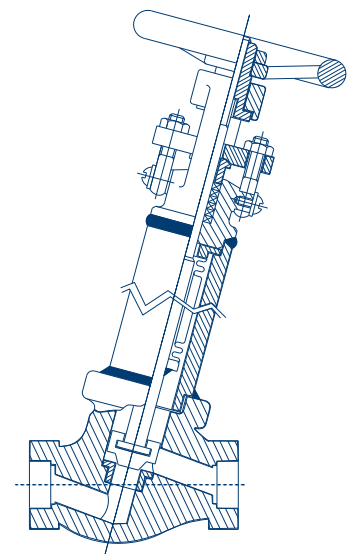

SOCKET / ROSCADA

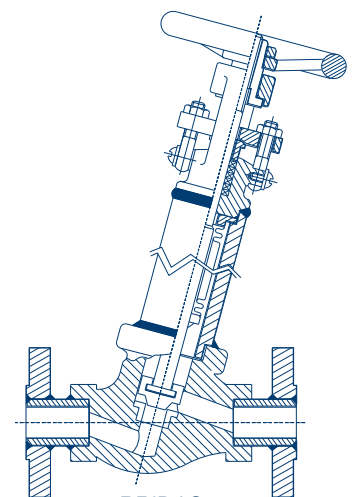

BRIDAS

DATOS TÉCNICOS

- » Diseño según BS5352/API 602 (paso estándar)
- » Pruebas según API 598
- » SW según ANSI B16.11
- » BW según ANSI B16.25
- » Rosca según ANSI B1.20.1 (BSP/BSPT/NPT)

VÁLVULA CON BRIDAS

- » Bridas según ANSI B16.5
- » Distancia entre caras según ANSI B16.10

ACCESORIOS

- » Actuador neumático
- » Enclavamiento del volante
- » Husillo extendido

GLOBO TIPO FUELLE 150/300LBS

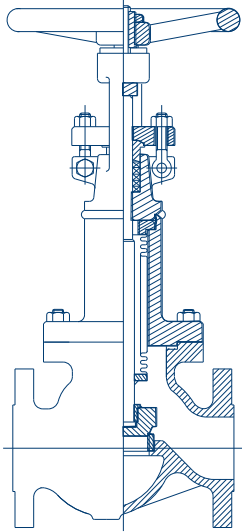

CON BRIDAS

UKL Globo tipo Fuelle		Clase: 150/300LBS
VÁLVULA GLOBO TIPO FUELLE		
Especificaciones		
Material	Acero carbono ASTM A216 WCB o ASTM A351 CF8/CF8M*	
Diseño	BS 1873 / ANSI B16.34	
Conexiones	Bridas según ASME B16.5 o Butt Weld según B16.25	
Longitud	ASME B16.10	
Inspección y Pruebas	API 598	
Diseño DIN	Bajo demanda	
Aplicaciones	Therminol-66, Dowtherm vapour, Hot Oil/HTM, Vacuum, Steam, Ammonia, Refrigerant, Phosgene, Chlorine, Hydrogen, Oxygen, CO, Hazardous and Poisonous liquids gases, Radioactive substances...	

* Otros materiales del cuerpo bajo demanda

Pos.	Pieza	Componentes	
		Acero carbono	Acero inoxidable
1	Cuerpo	ASTM A216 WCB	A351 CF8/CF8M
2	Tapa	ASTM A216 WCB	A351 CF8/CF8M
3	Cámara fuelle	ASTM A216 WCB	A351 CF8/CF8M
4	Obturador	WCB + 13% Cr / CA15 / AISI 410	CF8M / AISI 304 / 316
5	Asiento	WCB + 13% Cr / CA15 / AISI 410	CF8M / AISI 304 / 316
6	Husillo	AISI 410	AISI 304 / 316
7	Tuerca husillo	AISI 410	AISI 304 / 316
8	Fuelle	AISI 316Ti	AISI 316Ti
9	Junta	Espirometálica Grafito	Espirometálica PTFE
10	Empaquetadura	Espirometálica Grafito	PTFE
11	Casquillo prensa	AISI 410	AISI 304 / 316
12	Brida prensa	Acero carbono	AISI 304 / 316
13	Tornillo y tuerca	Acero carbono	AISI 304 / 316
14	Tornillo ojo y tuerca	Acero carbono	AISI 304 / 316
15	Camisa puente	Ni Resist	Ni Resist
16	Volante	Acero carbono	Acero carbono
17	Espárrago / tuerca	ASTM A193 B7 / A194 2H	ASTM A193 B7 / A194 2H
18	Collarín fuelle	AISI 316	AISI 316

PRESIÓN / TEMPERATURA

Presión prueba	150LBS	300LBS
Cuerpo (hidráulica)	32 kg/cm ²	79 kg/cm ²
Asiento (hidráulica)	23 kg/cm ²	58 kg/cm ²
Asiento (neumática)	7 kg/cm ²	7 kg/cm ²

DATOS TÉCNICOS

- » Diseño según BS1873/ANSI B16.34
- » Pruebas según API 598
- » Bridas según ANSI B16.5
- » BW según ANSI B16.25
- » Distancia entre caras según ANSI B16.10

ACCESORIOS

- » Reductor manual
- » Actuador neumático

NOTAS

- » Material del fuelle alternativo: Hastelloy C-276 / Monel / Inconel
- » Otros materiales del cuerpo bajo demanda

150LBS

Tamaño (mm)	15	20	25	40	50	65	80	100	150	200	250	300
Longitud total	108	118	127	165	203	216	241	292	406	495	622	698
Ø brida	89	98.5	108	127	152	178	191	229	279	343	406	482
Espesor brida	11	13	14.5	18	19	22	25	25	26	29	30	32
Ø R.F.	35	43	51	73	92	105	127	157	216	270	324	381
Espesor R.F.	2	2	2	2	2	2	2	2	2	2	2	2
Diámetro centro taladros	60.3	70	79.4	98.4	121	140	152	191	241	299	362	432
Número de taladros / Ø taladro	4/16	4/16	4/16	4/16	4/19	4/19	4/19	8/19	8/22	8/22	12/25	12/25

300LBS

Tamaño (mm)	15	20	25	40	50	65	80	100	150	200	250	300
Longitud total	153	178	203	229	267	292	318	356	445	559	622	711
Ø brida	96	117.5	124	156	165	191	210	254	318	381	445	521
Espesor brida	14.3	16	17.5	21	22	25	29	32	37	41	17	51
Ø R.F.	35	43	51	73	92	105	127	157	216	270	324	381
Espesor R.F.	2	2	2	2	2	2	2	2	2	2	2	2
Diámetro centro taladros	66.7	82.6	89	114	127	149	168	200	270	330	384	451
Número de taladros / Ø taladro	4/16	4/19	4/19	4/22	8/19	8/22	8/22	8/22	12/22	12/25	16/29	16/32

VÁLVULAS DE FUELLE

COMPUERTA TIPO FUELLE 150/300LBS

UKL Compuerta tipo Fuelle		Clase: 150/300LBS
VÁLVULA COMPUERTA TIPO FUELLE		
Especificaciones		
Material	Acero carbono ASTM A105 o A182 F304 / F316*	
Diseño	BS 5352 / API 602 (Paso estándar)	
Conexiones	SW según ANSI B16.11 o BW según B16.25 o NPT según B1.20.1	
Longitud	Estándar del fabricante	
Inspección y Pruebas	API 598	
Diseño DIN	Bajo demanda	
Aplicaciones	Therminol-66, Dowtherm vapour, Hot Oil/HTM, Vacuum, Steam, Ammonia, Refrigerant, Phosgene, Chlorine, Hydrogen, Oxygen, CO, Hazardous and Poisonous liquids gases, Radioactive substances...	

* Otros materiales del cuerpo bajo demanda

Pos.	Pieza	Componentes	
		Acero carbono	Acero inoxidable
1	Cuerpo	ASTM A105	A182 F304 / F316
2	Tapa	ASTM A105	A182 F304 / F316
3	Obturador	AISI 410	AISI 304 / 316
4	Asiento	AISI 410	AISI 304 / 316
5	Husillo	AISI 410	AISI 304 / 316
6	Fuelle	AISI 316Ti	AISI 316Ti
7	Empaquetadura	Grafito	PTFE
8	Tornillo ojo y tuerca	Acero carbono	AISI 304 / 316
9	Casquillo prensa	AISI 410	AISI 304 / 316
10	Brida prensaestopas	Acero carb. / A105	AISI 304 / 316
11	Puente	Ni-Resist	Ni-Resist
12	Volante	Hierro / Acero carb.	Hierro / Acero carb.
13	Bridas	A105	Acero inoxidable
14	Cilindro	A106 Gr. B	Acero inoxidable
15	Collarín fuelle	AISI 316	AISI 316

PRESIÓN / TEMPERATURA

Presión prueba	150LBS	300LBS
Cuerpo (hidráulica)	32 kg/cm ²	79 kg/cm ²
Asiento (hidráulica)	23 kg/cm ²	58 kg/cm ²
Asiento (neumática)	7 kg/cm ²	7 kg/cm ²

150LBS

Tamaño (mm)	15	20	25	40
Longitud total	108	118	127	165
Ø brida	89	98.5	108	127
Espesor brida	11	13	14.5	17.5
Ø R.F.	35	43	51	73
Espesor R.F.	2	2	2	2
Diámetro centro taladros	60.3	70	79.4	98.4
Número de taladros / Ø taladro	4/16	4/16	4/16	4/16

300LBS

Tamaño (mm)	15	20	25	40
Longitud total	153	178	203	229
Ø brida	96	117.5	124	156
Espesor brida	14.3	16	17.5	21
Ø R.F.	35	43	51	73
Espesor R.F.	2	2	2	2
Diámetro centro taladros	66.7	82.6	89	114.3
Número de taladros / Ø taladro	4/16	4/19	4/19	4/22

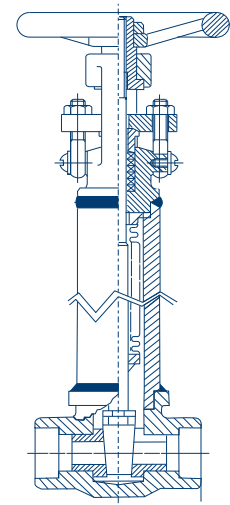

SOCKET WELD

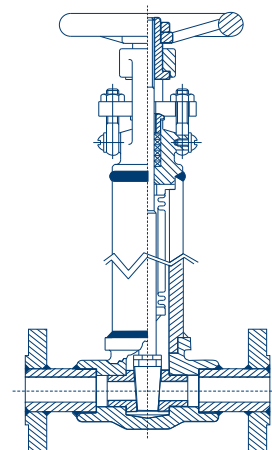

BRIDAS

DATOS TÉCNICOS

- » Diseño según BS5352/API 602 (paso reducido)
- » Pruebas según API 598
- » SW según ANSI B16.11
- » BW según ANSI B16.25
- » Rosca según ANSI B1.20.1 (BSP/BSPT/NPT)

VÁLVULA CON BRIDAS

- » Bridas según ANSI B16.5
- » Distancia entre caras según ANSI B16.10

ACCESORIOS

- » Actuador neumático
- » Enclavamiento del volante
- » Husillo extendido

COMPUERTA TIPO FUELLE 150/300LBS

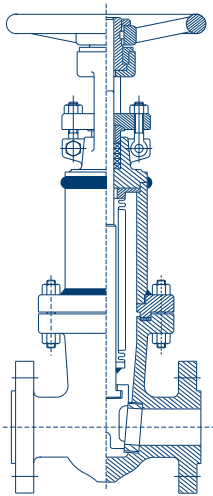

CON BRIDAS

UKL Compuerta tipo Fuelle		Clase: 150/300LBS
VÁLVULA COMPUERTA TIPO FUELLE		
Especificaciones		
Material	Acero carbono ASTM A216 WCB o ASTM A352 LCB/LCC*	
Diseño	API 600	
Conexiones	Bridas según ASME B16.5 o Butt Weld según B16.25	
Longitud	ASME B16.10	
Inspección y Pruebas	API 598	
Diseño DIN	Bajo demanda	
Aplicaciones	Therminol-66, Dowtherm vapour, Hot Oil/HTM, Vacuum, Steam, Ammonia, Refrigerant, Phosgene, Chlorine, Hydrogen, Oxygen, CO, Hazardous and Poisonous liquids gases, Radioactive substances...	

* Otros materiales del cuerpo bajo demanda

Pos.	Pieza	Componentes	
		Acero carbono	Acero inoxidable
1	Cuerpo	ASTM A216 WCB	A351 CF8 / CF8M
2	Tapa	ASTM A216 WCB	A351 CF8 / CF8M
3	Cámara fuelle	ASTM A216 WCB / A106 Gr. B	A351 CF8 / CF8M
4	Obturador	WCB + 13% Cr / CA15 / AISI 410	CF8M / AISI 304 / 316
5	Asiento	WCB + 13% Cr / CA15 / AISI 410	CF8M / AISI 304 / 316
6	Husillo	AISI 410	AISI 304 / 316
7	Fuelle	AISI 316Ti	AISI 316Ti
8	Junta	Espirometálica Grafito	Espirometálica PTFE
9	Empaquetadura	Grafito	PTFE
10	Casquillo prensa	AISI 410	AISI 304 / 316
11	Brida prensaestopas	Acero carbono	AISI 304 / 316
12	Tornillo y tuerca	Acero carbono	AISI 304 / 316
13	Tornillo de ojo y tuerca	Acero carbono	AISI 304 / 316
14	Camisa puente	Ni Resist	Ni Resist
15	Volante	Acero carbono	Acero carbono
16	Espárrago / tuerca	ASTM A193 Gr. B7 / A194 Gr. 2H	ASTM A193 Gr. B8 / A194 Gr. 8
17	Collarín fuelle	AISI 316	AISI 316

PRESIÓN / TEMPERATURA

Presión prueba	150LBS	300LBS
Cuerpo (hidráulica)	32 kg/cm ²	79 kg/cm ²
Asiento (hidráulica)	23 kg/cm ²	58 kg/cm ²
Asiento (neumática)	7 kg/cm ²	7 kg/cm ²

DATOS TÉCNICOS

- » Diseño según API 600
- » Pruebas según API 598
- » Bridas según ANSI B16.5
- » BW según ANSI B16.25
- » Distancia entre caras según ANSI B16.10

ACCESORIOS

- » Reductor manual
- » Actuador neumático

NOTAS

- » Construcción según normas DIN bajo demanda

150LBS

Tamaño (mm)	50	65	80	100	150	200	250	300
Longitud total	178	191	203	229	267	290	330	355
Ø brida	152	178	191	229	279	343	406	483
Espesor brida	19	22	22	24	26	29	30	32
Ø R.F.	92	105	127	157	216	270	324	381
Espesor R.F.	2	2	2	2	2	2	2	2
Diámetro centro taladros	121	140	152	191	241	299	362	432
Número de taladros / Ø taladro	4/19	4/19	4/19	8/19	8/22	8/22	12/25	12/25

300LBS

Tamaño (mm)	50	65	80	100	150	200	250	300
Longitud total	216	241	283	305	403	419	457	502
Ø brida	165	191	210	254	318	381	444	521
Espesor brida	22	26	29	32	37	41	47	51
Ø R.F.	92	105	127	157	216	270	324	381
Espesor R.F.	2	2	2	2	2	2	2	2
Diámetro centro taladros	127	149	168	200	270	330	387	451
Número de taladros / Ø taladro	8/19	8/22	8/22	8/22	12/22	12/25	16/28	16/32

VÁLVULAS DE FUELLE

GLOBO TIPO FUELLE PN40/300LBS SERVICIO CLORO

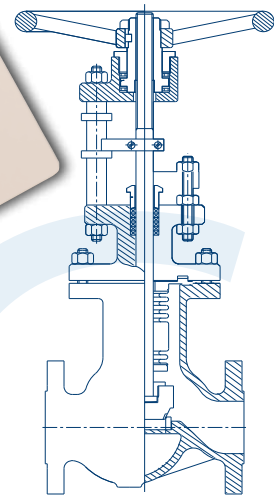

CON BRIDAS

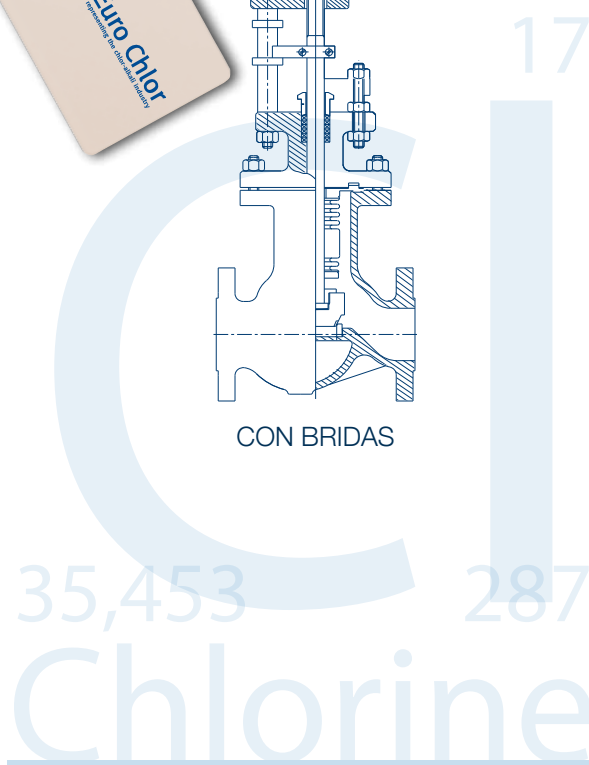

UKL Globo tipo Fuelle Servicio Cloro		Clase: PN40/300LBS
VÁLVULA GLOBO TIPO FUELLE		
Especificaciones		
Material	Acero carbono ASTM A216 WCB o A352 LCB/LCC*	
Diseño	BS 1873	
Conexiones	Bridas según ANSI B16.5 o Butt Welding según ANSI B16.25	
Longitud	Según ANSI B16.10	
Inspección y Pruebas	API 598	
Diseño DIN	Bajo demanda	
Aplicaciones	Therminol-66, Dowtherm vapour, Hot Oil/HTM, Vacuum, Steam, Ammonia, Refrigerant, Phosgene, Chlorine, Hydrogen, Oxygen, CO, Hazardous and Poisonous liquids gases, Radioactive substances...	

* Otros materiales del cuerpo bajo demanda

Componentes		
Pos.	Pieza	Acero carbono fundido
1	Cuerpo	ASTM A216 WCB / A352 LCB / LCC
2	Tapa	ASTM A216 WCB / A352 LCB / LCC
3	Obturador	HC / Monel / AISI 316L / LCB
4	Asiento	HC / Monel / AISI 316L / LCB
5	Husillo	HC / Monel / AISI 316L
6	Junta	Espirometálica PTFE
7	Fuelle	Hastelloy C-276 / 316Ti
8	Collarín fuelle	Hastelloy C-276 / AISI 316L
9	Espárrago / tuerca	ASTM A193 G. B8 / ASTM A194 Gr. 8
10	Prensaestopas	HC / Monel / AISI 316L
11	Empaquetadura	PTFE
12	Casquillo prensa	HC / Monel / AISI 316L
13	Brida prensaestopas	AISI 304 / 316 / LCB
14	Tornillo y tuerca	AISI 304 / 316
15	Camisa puente	Ni Resist
16	Volante	Acero carbono
17	Soportes	AISI 410

PRESIÓN / TEMPERATURA

Presión prueba	PN 40	300LBS
Cuerpo (hidráulica)	64 kg/cm ²	79 kg/cm ²
Asiento (hidráulica)	40 kg/cm ²	58 kg/cm ²
Asiento (neumática)	7 kg/cm ²	7 kg/cm ²

DATOS TÉCNICOS

- » Diseño según BS 1873
- » Pruebas según API 598
- » Bridas según ANSI B16.5
- » BW según ANSI B16.25
- » Distancia entre caras según ANSI B16.10

PN 40

Tamaño (mm)	15	20	25	40	50	65	80	100	150
Longitud total	130	150	160	200	230	290	310	350	480
Ø brida	95	105	115	150	165	185	200	235	360
Espesor brida	16	18	18	18	20	22	24	24	28
Ø R.F.	45	58	68	88	102	122	138	162	218
Espesor R.F.	2	2	2	2	2	3	3	3	3
Diámetro centro taladros	65	75	85	110	125	145	160	190	250
Número de taladros / Ø taladro	4/14	4/14	4/14	4/18	4/18	8/18	8/18	8/22	8/26

300LBS

Tamaño (mm)	15	20	25	40	50	65	80	100	150
Longitud total	153	178	203	229	269	292	318	356	445
Ø brida	95	118	124	156	165	191	210	254	318
Espesor brida	14	16	18	21	22	25	29	32	37
Ø R.F.	35	43	51	73	92	105	127	157	216
Espesor R.F.	2	2	2	2	2	2	2	2	2
Diámetro centro taladros	67	83	89	114	127	149	168	200	270
Número de taladros / Ø taladro	4/16	4/19	4/19	4/22	8/19	8/22	8/22	8/22	12/22

GLOBO TIPO FUELLE 150/300LBS SERVICIO CRIOGÉNICO

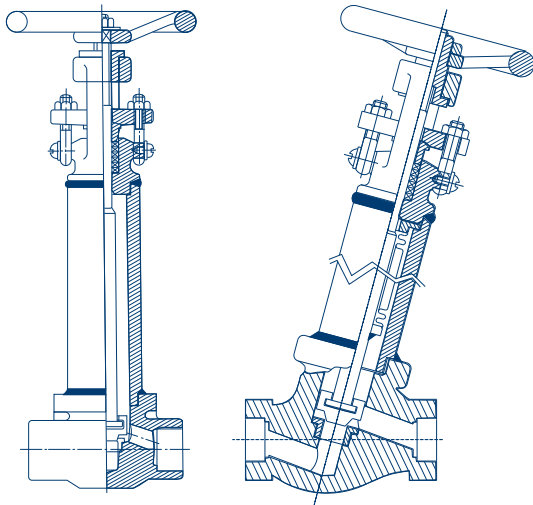

SOCKET / ROSCADA

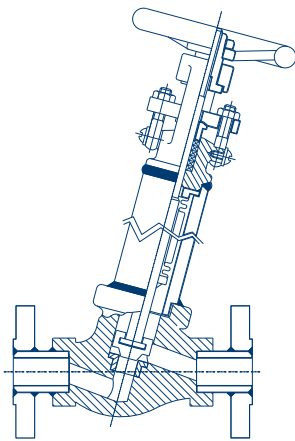

CON BRIDAS

UKL Globo tipo Fuelle Servicio Criogénico		Clase: 150/300LBS
VÁLVULA GLOBO TIPO FUELLE		
Especificaciones		
Material	Acero inoxidable ASTM A182 F304 / F316*	
Diseño	BS 5352 / API 602 (Paso estándar)	
Conexiones	Bridas según ASME B16.5 o SW según B16.11 o BW según B16.25	
Longitud	Según el estándar del fabricante	
Inspección y Pruebas	API 598	
Diseño DIN	Bajo demanda	
Aplicaciones	Therminol-66, Dowtherm vapour, Hot Oil/HTM, Vacuum, Steam, Ammonia, Refrigerant, Phosgene, Chlorine, Hydrogen, Oxygen, CO, Hazardous and Poisonous liquids gases, Radioactive substances...	

* Otros materiales del cuerpo bajo demanda

Componentes		
Pos.	Pieza	Acero inoxidable
1	Cuerpo	A351 F304 / F316
2	Tapa	A351 F304 / F316
3	Obturador	AISI 304 / 316
4	Asiento	AISI 304 / 316
5	Husillo	AISI 304 / 316
6	Fuelle	AISI 316Ti
7	Empaquetadura	PTFE
8	Tornillo de ojo y tuerca	AISI 304 / 316
9	Casquillo prensa	AISI 304 / 316
10	Brida prensaestopas	AISI 304 / 316
11	Puente	Ni Resist
12	Volante	Hierro fundido / Acero carbono
13	Bridas	Acero inoxidable
14	Cilindro	Acero inoxidable
15	Collarín fuelle	AISI 316

PRESIÓN / TEMPERATURA

Presión prueba	150LBS	300LBS
Cuerpo (hidráulica)	32 kg/cm ²	79 kg/cm ²
Asiento (hidráulica)	23 kg/cm ²	58 kg/cm ²
Asiento (neumática)	7 kg/cm ²	7 kg/cm ²

150LBS

Tamaño (mm)	15	20	25	40
Longitud total	108	118	127	165
Ø brida	89	98.5	108	127
Espesor brida	11	13	14.5	17.5
Ø R.F.	35	43	51	73
Espesor R.F.	2	2	2	2
Diámetro centro taladros	60.3	70	79.4	98.4
Número de taladros / Ø taladro	4/16	4/16	4/16	4/16

300LBS

Tamaño (mm)	15	20	25	40
Longitud total	153	178	203	229
Ø brida	96	117.5	124	156
Espesor brida	14.3	16	17.5	21
Ø R.F.	35	43	51	73
Espesor R.F.	2	2	2	2
Diámetro centro taladros	66.7	82.6	89	114.3
Número de taladros / Ø taladro	4/16	4/19	4/19	4/22

DATOS TÉCNICOS

- » Diseño según BS 5352 / API 602 (Paso estándar)
- » Pruebas según API 598
- » SW según ANSI B16.11
- » BW según ANSI B16.25
- » NPT según ANSI B1.20.1 (BSP/BSPT/NPT)
- » Distancias según el estándar del fabricante

EXTREMOS BRIDADOS

- » Bridas según ANSI B16.5
- » Distancia entre caras según ANSI B16.10

ACCESORIOS

- » Actuador neumático
- » Enclavamiento del volante
- » Husillo extendido

VÁLVULAS DE FUELLE

GLOBO TIPO FUELLE 150/300LBS SERVICIO CRIOGÉNICO

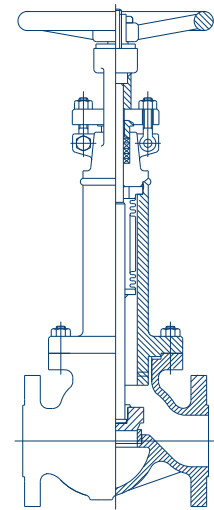

CON BRIDAS

UKL Globo tipo Fuelle Servicio Criogénico		Clase: 150/300LBS
VÁLVULA GLOBO TIPO FUELLE		
Especificaciones		
Material	Acero carbono ASTM A352 LCB/LCC o A351 CF8/CF8M*	
Diseño	BS 1873/ ANSI B16.34	
Conexiones	Bridas según ANSI B16.5 o Butt Welding según ANSI B16.25	
Longitud	Según ANSI B16.10	
Inspección y Pruebas	API 598	
Diseño DIN	Bajo demanda	
Aplicaciones	Therminol-66, Dowtherm vapour, Hot Oil/HTM, Vacuum, Steam, Ammonia, Refrigerant, Phosgene, Chlorine, Hydrogen, Oxygen, CO, Hazardous and Poisonous liquids gases, Radioactive substances...	

* Otros materiales del cuerpo bajo demanda

Pos.	Pieza	Componentes	
		Acero carbono	Acero inoxidable
1	Cuerpo	ASTM A352 LCB / LCC	ASTM A351 CF8 / CF8M
2	Tapa	ASTM A352 LCB / LCC	ASTM A351 CF8 / CF8M
3	Cámara fuelle	ASTM A352 LCB / LCC / A106	ASTM A351 CF8 / CF8M
4	Obturador	ASTM A352 LCB / LCC / CA 15	ASTM A351 CF8 / CF8M
5	Asiento	AISI 304 / LCB / LCC	AISI 304 / 316
6	Husillo	AISI 304	AISI 304 / 316
7	Junta	Espirometálica	Espirometálica
8	Fuelle	AISI 316Ti	AISI 316Ti
9	Espárrago / tuerca	ASTM A193 Gr. B7	ASTM A193 Gr. B8
10	Empaquetadura	ASTM A194 Gr. 2H	ASTM A194 Gr. 8
11	Casquillo prensa	PTFE	PTFE
12	Brida prensaestopas	AISI 304	AISI 304 / 316
13	Tornillo y tuerca	AISI 304	AISI 304
14	Tornillo de ojo y tuerca	AISI 304	AISI 304
15	Camisa puente	Ni Resist	Ni Resist
16	Volante	Acero carbono	Acero carbono
17	Collarín fuelle	AISI 316	AISI 316

PRESIÓN / TEMPERATURA

Presión prueba	150LBS	300LBS
Cuerpo (hidráulica)	32 kg/cm ²	79 kg/cm ²
Asiento (hidráulica)	23 kg/cm ²	58 kg/cm ²
Asiento (neumática)	7 kg/cm ²	7 kg/cm ²

150LBS

Tamaño (mm)	15	20	25	40	50	65	80	100	150	200
Longitud total	108	118	127	165	203	216	241	292	406	495
Ø brida	89	98.5	108	127	152	178	191	229	279	343
Espesor brida	11	13	14.5	18	19	22	25	25	26	29
Ø R.F.	35	43	51	73	92	105	127	157	216	270
Espesor R.F.	2	2	2	2	2	2	2	2	2	2
Diámetro centro taladros	60.3	70	79.4	98.4	121	140	152	191	241	299
Número de taladros / Ø taladro	4/16	4/16	4/16	4/16	4/19	4/19	4/19	8/19	8/22	8/22

300LBS

Tamaño (mm)	15	20	25	40	50	65	80	100	150	200
Longitud total	153	178	203	229	267	292	318	356	445	559
Ø brida	96	117.5	124	156	165	191	210	254	318	381
Espesor brida	14.3	16	17.5	21	22	25	29	32	37	41
Ø R.F.	35	43	51	73	92	105	127	157	216	270
Espesor R.F.	2	2	2	2	2	2	2	2	2	2
Diámetro centro taladros	66.7	82.6	89	114	127	149	168	200	270	330
Número de taladros / Ø taladro	4/16	4/19	4/19	4/32	8/19	8/22	8/22	8/22	12/22	12/25

DATOS TÉCNICOS

- » Diseño según BS 1873 / ANSI B16.34
- » Pruebas según API 598
- » Bridas según ANSI B16.5
- » BW según ANSI B16.25
- » Distancia entre caras según ANSI B16.10
- » Válvulas según normas DIN bajo demanda

ACCESORIOS

- » Reductor manual
- » Actuador neumático

COMPUERTA TIPO FUELLE 150/300LBS SERVICIO CRIOGÉNICO

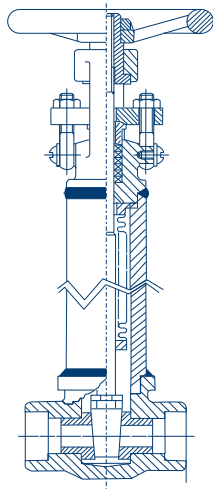

SOCKET / ROSCADA

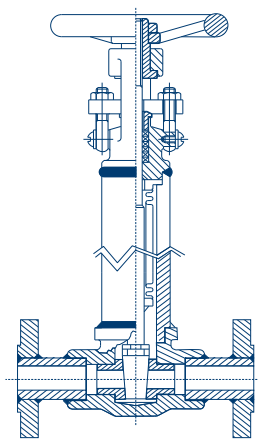

CON BRIDAS

UKL Compuerta tipo Fuelle Servicio Criogénico		Clase: 150/300LBS
VÁLVULA COMPUERTA TIPO FUELLE		
Especificaciones		
Material	Acero inoxidable ASTM A182 F304 / F316*	
Diseño	BS 5352 / API 602 (Paso reducido)	
Conexiones	Bridas según ASME B16.5 o SW según B16.11 o BW según B16.25	
Longitud	Según el estándar del fabricante	
Inspección y Pruebas	API 598	
Diseño DIN	Bajo demanda	
Aplicaciones	Therminol-66, Dowtherm vapour, Hot Oil/HTM, Vacuum, Steam, Ammonia, Refrigerant, Phosgene, Chlorine, Hydrogen, Oxygen, CO, Hazardous and Poisonous liquids gases, Radioactive substances...	

* Otros materiales del cuerpo bajo demanda

Componentes		
Pos.	Pieza	Acero inoxidable
1	Cuerpo	A351 F304 / F316
2	Tapa	A351 F304 / F316
3	Obturador	AISI 304 / 316
4	Asiento	AISI 304 / 316
5	Husillo	AISI 304 / 316
6	Fuelle	AISI 316Ti
7	Empaquetadura	PTFE
8	Tornillo de ojo y tuerca	AISI 304 / 316
9	Casquillo prensa	AISI 304 / 316
10	Brida prensaestopas	AISI 304 / 316
11	Puente	Ni Resist
12	Volante	Hierro fundido / Acero carbono
13	Bridas	Acero inoxidable
14	Cilindro	Acero inoxidable
15	Collarín fuelle	AISI 316

PRESIÓN / TEMPERATURA

Presión prueba	150LBS	300LBS
Cuerpo (hidráulica)	32 kg/cm ²	79 kg/cm ²
Asiento (hidráulica)	23 kg/cm ²	58 kg/cm ²
Asiento (neumática)	7 kg/cm ²	7 kg/cm ²

150LBS

Tamaño (mm)	15	20	25	40
Longitud total	108	118	127	165
Ø brida	89	98.5	108	127
Espesor brida	11	13	14.5	17.5
Ø R.F.	35	43	51	73
Espesor R.F.	2	2	2	2
Diámetro centro taladros	60.3	70	79.4	98.4
Número de taladros / Ø taladro	4/16	4/16	4/16	4/16

300LBS

Tamaño (mm)	15	20	25	40
Longitud total	153	178	203	229
Ø brida	96	117.5	124	156
Espesor brida	14.3	16	17.5	21
Ø R.F.	35	43	51	73
Espesor R.F.	2	2	2	2
Diámetro centro taladros	66.7	82.6	89	114.3
Número de taladros / Ø taladro	4/16	4/19	4/19	4/22

DATOS TÉCNICOS

- » Diseño según BS 5352 / API 602 (Paso reducido)
- » Pruebas según API 598
- » SW según ANSI B16.11
- » BW según ANSI B16.25
- » NPT según ANSI B1.20.1 (BSP/BSPT/NPT)
- » Distancias según el estándar del fabricante

EXTREMOS BRIDADOS

- » Bridas según ANSI B16.5
- » Distancia entre caras según ANSI B16.10

ACCESORIOS

- » Actuador neumático
- » Enclavamiento del volante
- » Husillo extendido

VÁLVULAS DE FUELLE

COMPUERTA TIPO FUELLE 150/300LBS SERVICIO CRIOGÉNICO

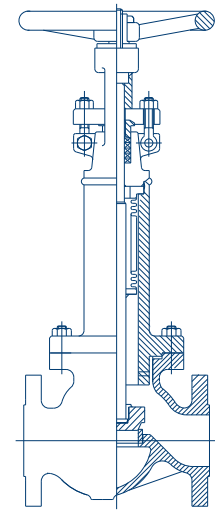

CON BRIDAS

UKL Compuerta tipo Fuelle Servicio Criogénico		Clase: 150/300LBS
VÁLVULA COMPUERTA TIPO FUELLE		
Especificaciones		
Material	Acero carbono ASTM A352 LCB/LCC o A351 CF8/CF8M*	
Diseño	API 600	
Conexiones	Bridas según ANSI B16.5 o Butt Welding según ANSI B16.25	
Longitud	Según ANSI B16.10	
Inspección y Pruebas	API 598	
Diseño DIN	Bajo demanda	
Aplicaciones	Therminol-66, Dowtherm vapour, Hot Oil/HTM, Vacuum, Steam, Ammonia, Refrigerant, Phosgene, Chlorine, Hydrogen, Oxygen, CO, Hazardous and Poisonous liquids gases, Radioactive substances...	

* Otros materiales del cuerpo bajo demanda

Pos.	Pieza	Componentes	
		Acero carbono	Acero inoxidable
1	Cuerpo	ASTM A352 LCB / LCC	ASTM A351 CF8 / CF8M
2	Tapa	ASTM A352 LCB / LCC	ASTM A351 CF8 / CF8M
3	Cámara fuelle	Acero calmado	Acero inoxidable
4	Obturador	AISI 304 / LCB / LCC	ASTM A351 CF8 / CF8M
5	Asiento	AISI 304 / LCB / LCC	AISI 304 / 316
6	Husillo	AISI 304	AISI 304 / 316
7	Junta	Espirometálica	Espirometálica
8	Espárrago / tuerca	A193 B7 / A194 2H	A193 B8 / A194 Gr. 8
9	Casquillo tapa	AISI 304	AISI 304 / 316
10	Empaquetadura	PTFE	PTFE
11	Casquillo prensa	AISI 304	AISI 304 / 316
12	Brida prensaestopas	AISI 304	AISI 304
13	Tornillo y tuerca	AISI 304	AISI 304
14	Tornillo de ojo y tuerca	AISI 304	AISI 304
15	Camisa puente	Ni Resist	Ni Resist
16	Volante	Acero carbono	Acero carbono
17	Fuelle	AISI 316Ti	AISI 316Ti
18	Collarín fuelle	AISI 316	AISI 316

PRESIÓN / TEMPERATURA

Presión prueba	150LBS	300LBS
Cuerpo (hidráulica)	32 kg/cm ²	79 kg/cm ²
Asiento (hidráulica)	23 kg/cm ²	58 kg/cm ²
Asiento (neumática)	7 kg/cm ²	7 kg/cm ²

DATOS TÉCNICOS

- » Diseño según API 600
- » Pruebas según API 598
- » Bridas según ANSI B16.5
- » BW según ANSI B16.25
- » Distancia entre caras según ANSI B16.10
- » Válvulas según normas DIN bajo demanda

150LBS

Tamaño (mm)	50	65	80	100	150	200	250	300
Longitud total	178	191	203	229	267	292	330	355
Ø brida	152	178	191	229	279	343	406	483
Espesor brida	19	22	22	24	26	29	30	32
Ø R.F.	92	105	127	157	216	270	324	381
Espesor R.F.	2	2	2	2	2	2	2	2
Diámetro centro taladros	121	140	152	191	241	299	362	432
Número de taladros / Ø taladro	4/19	4/19	4/19	8/19	8/22	8/22	12/25	12/25

300LBS

Tamaño (mm)	50	65	80	100	150	200	250	300
Longitud total	216	241	283	305	403	419	457	502
Ø brida	165	191	210	254	318	381	444	521
Espesor brida	22	26	29	32	37	41	47	51
Ø R.F.	92	105	127	157	216	270	324	381
Espesor R.F.	2	2	2	2	2	2	2	2
Diámetro centro taladros	127	149	168	200	270	330	387	451
Número de taladros / Ø taladro	8/19	8/22	8/22	8/22	12/22	12/25	16/28	16/32



VÁLVULAS DE FUELLE RK®



VÁLVULAS DE FUELLE

GLOBO TIPO FUELLE HIERRO FUNDIDO PN16 PASO RECTO

RK-Z Fuelle PN16		Tipo: Paso Recto
GG25 PN16 - BRIDAS		
Especificaciones		
Material	Hierro Fundido EN-GJL-250	
Asiento	Acero inoxidable X12 Cr 13	
Disco	Acero inoxidable X20 Cr 13	
Fuelle	X6 Cr Ni Mo Ti 17.12.2	
Conexiones	Bridas según EN 1092-1/2	
Estanqueidad	Clase A según EN 12266-1	
Distancia entre caras	EN 558-1 Serie 1	
Inspección y Pruebas	EN 12266-1	
Certificados	PED 97/23/EC para DN ≥ 32	



* Otras ejecuciones especiales (p.ej. con **cono de regulación**) bajo demanda

Componentes		
Pos.	Denominación	Material
1	Cuerpo	EN-GJL-250
2	Asiento	X12 Cr 13 (1.4006)
3	Tapa	EN-GJS400-18-LT
4	Husillo	X20 Cr 13 (1.4021)
5	Volante	Acero
6	Prensaestopas	11 S Mn Pb 30
7	Obturador	X20 Cr 13 (1.4021)
8	Fuelle	X6 Cr Ni Mo Ti 17.12.2
9	Camisa	11 S Mn Pb 30
10	Empaquetadura	Grafito
11	Junta cuerpo-tapa	Grafito + Cr Ni St
12	Tornillo hexagonal	8.8

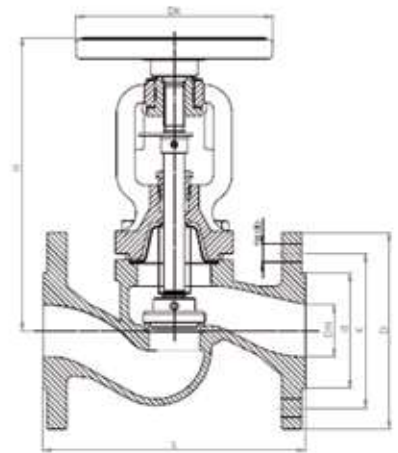

Válvula de Fuelle **GG25/13%Cr** PN16 RF DN-15/250 Paso Recto

Código	Dimensiones (mm.)												
	DN	D	d	K	PN16					Regulación			
					n x do	Dk	h	L	H	Kvs	kg	Kvs	kg
	15	95	46	65	4 x 14	125	5	130	178	5.9	3.2	3.4	3.2
010114310130001	20	105	56	75	4 x 14	125	5	150	178	7.4	3.9	6.3	3.9
010114310130002	25	115	65	85	4 x 14	125	7	160	193	13.0	4.6	9.4	5.0
010114310130003	32	140	76	100	4 x 19	125	8	180	201	18.0	6.5	16.0	6.7
010114310130004	40	150	84	110	4 x 19	150	10	200	224	30.0	9.0	26.0	9.3
010114310130005	50	165	99	125	4 x 19	150	13	230	228	41.0	11.0	40.0	11.5
010114310130006	65	185	118	145	4 x 19	175	17	290	270	79.0	15.8	70.0	16.3
010114310130007	80	200	132	160	8 x 19	200	20	310	295	115	20.5	106	21.4
010114310130008	100	220	156	180	8 x 19	250	25	350	321	181	35.0	170	36.0
010114310130009	125	250	184	210	8 x 19	300	32	400	388	225	49.0	245	51.5
010114310130010	150	285	211	240	8 x 23	400	38	480	448	364	76.0	360	78.0
010114310130011	200	340	266	295	12 x 23	500	50	600	575	725	130.5	-	130.5
010114310130012	250	405	319	355	12 x 28	500	63	730	645	-	210	-	-

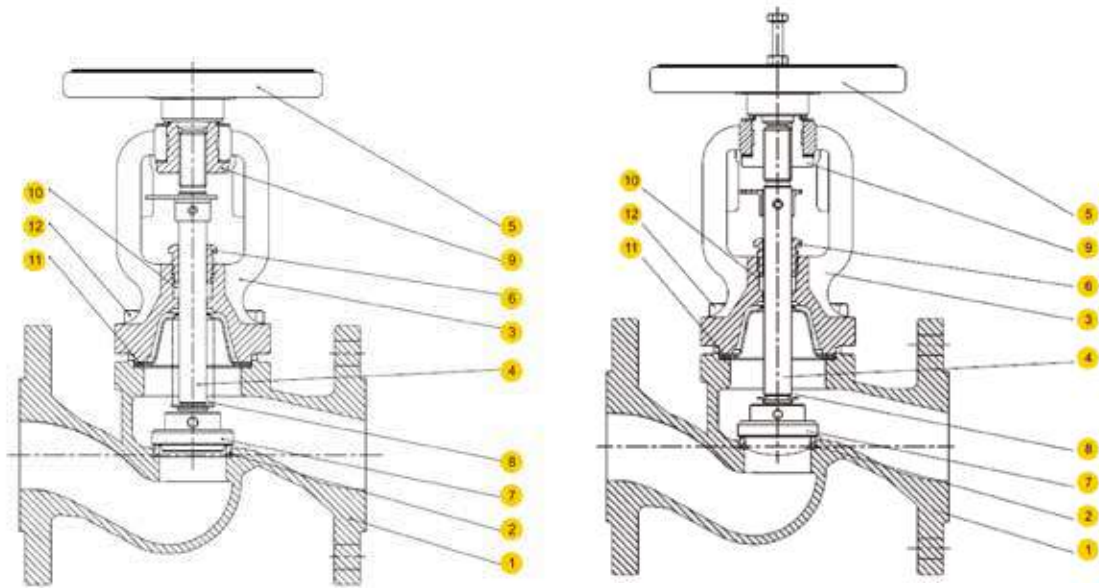

MODELO ESTÁNDAR

CON DISCO DE REGULACIÓN

Gráfico Presión / Temperatura

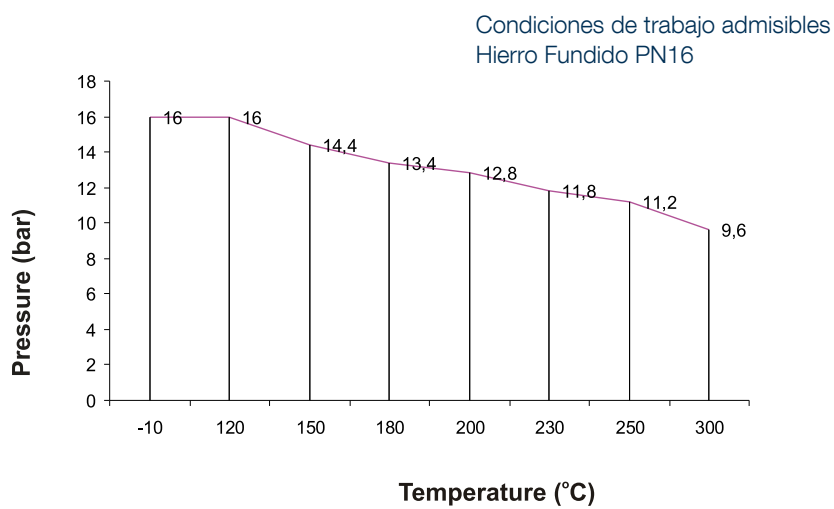

VÁLVULAS DE FUELLE

GLOBO TIPO FUELLE FUNDICIÓN NODULAR PN16 PASO RECTO

RK-Z Fuelle PN16		Tipo: Paso Recto
GGG40 PN16 - BRIDAS		
Especificaciones		
Material	Fundición Nodular EN-GJS-400-18-LT	
Asiento	Acero inoxidable X12 Cr 13	
Disco	Acero inoxidable X12 Cr 13	
Fuelle	X6 Cr Ni Mo Ti 17.12.2	
Conexiones	Bridas según EN 1092-1/2	
Estanqueidad	Clase A según EN 12266-1	
Distancia entre caras	EN 558-1 Serie 1	
Inspección y Pruebas	EN 12266-1	
Certificados	PED 97/23/EC para DN ≥ 32	



• Otras ejecuciones especiales (p.ej. con **cono de regulación**) bajo demanda

Componentes		
Pos.	Denominación	Material
1	Cuerpo	EN-GJS-400-18-LT
2	Asiento	X12 Cr 13 (1.4006)
3	Tapa	EN-GJS400-18-LT
4	Husillo	X20 Cr 13 (1.4021)
5	Volante	Acero
6	Prensaestopas	11 S Mn Pb 30
7	Obturador	X20 Cr 13 (1.4021)
8	Fuelle	X6 Cr Ni Mo Ti 17.12.2
9	Camisa	11 S Mn Pb 30
10	Empaquetadura	Grafito
11	Junta cuerpo-tapa	Grafito + Cr Ni St
12	Tornillo hexagonal	A2 70

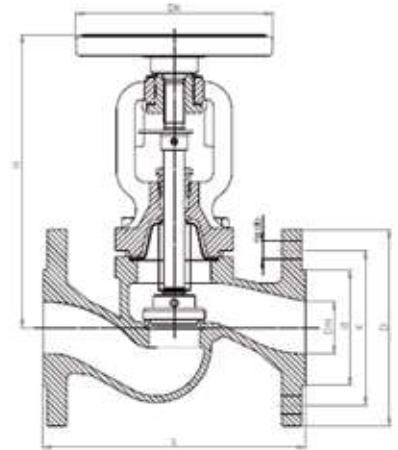

Válvula de Fuelle GGG40/13%Cr PN16 RF DN-15/200 Paso Recto

Código	Dimensiones (mm.)												
	DN	D	d	K	PN16					Regulación			
					n x do	Dk	h	L	H	Kvs	kg	Kvs	kg
010114310130013	15	95	46	65	4 x 14	125	5	130	178	5.9	3.2	3.4	3.2
010114310130014	20	105	56	75	4 x 14	125	5	150	178	7.4	3.9	6.3	3.9
010114310130015	25	115	65	85	4 x 14	125	7	160	193	13.0	4.6	9.4	5.0
010114310130016	32	140	76	100	4 x 19	125	8	180	201	18.0	6.5	16.0	6.7
010114310130017	40	150	84	110	4 x 19	150	10	200	224	30.0	9.0	26.0	9.3
010114310130018	50	165	99	125	4 x 19	150	13	230	228	41.0	11.0	40.0	11.5
010114310130019	65	185	118	145	4 x 19	175	17	290	270	79.0	15.8	70.0	16.3
010114310130020	80	200	132	160	8 x 19	200	20	310	295	115	20.5	106	21.4
010114310130021	100	220	156	180	8 x 19	250	25	350	321	181	35.0	170	36.0
010114310130022	125	250	184	210	8 x 19	300	32	400	388	225	49.0	245	51.5
010114310130023	150	285	211	240	8 x 23	400	38	480	448	364	76.0	360	78.0
010114310130024	200	340	266	295	12 x 23	500	50	600	575	725	130.5	-	130.5

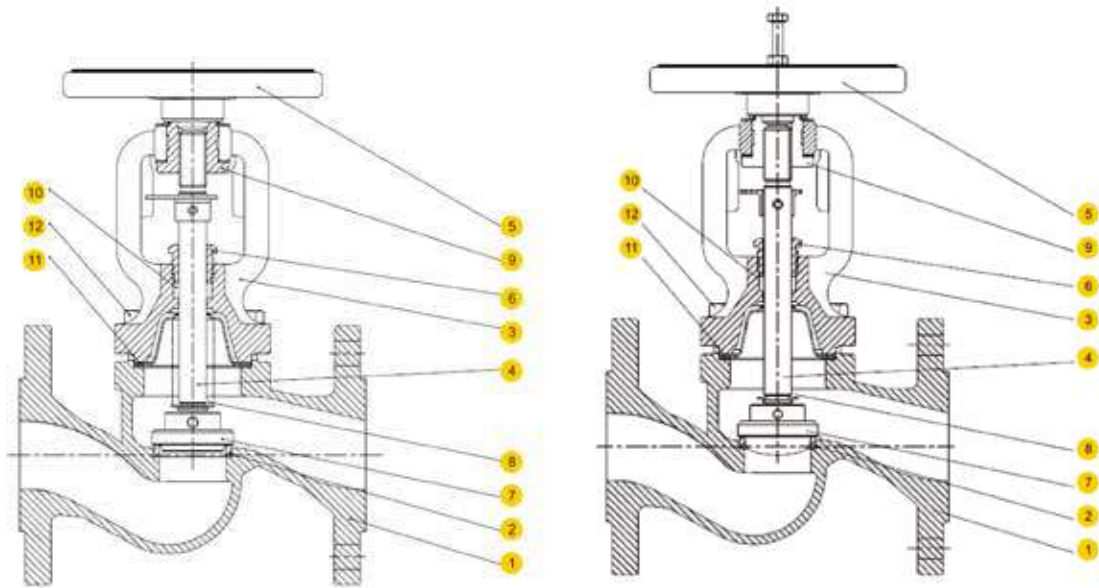

MODELO ESTÁNDAR

CON DISCO DE REGULACIÓN

Gráfico Presión / Temperatura

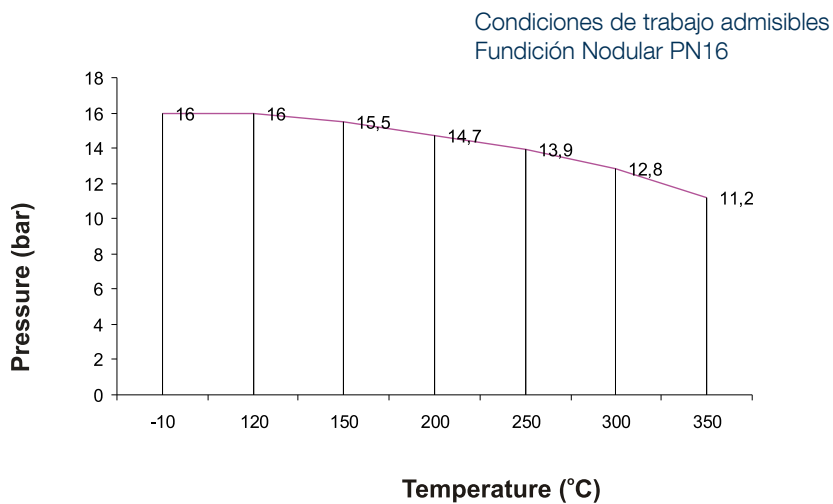

VÁLVULAS DE FUELLE

GLOBO TIPO FUELLE FUNDICIÓN NODULAR PN25 PASO RECTO

RK-Z Fuelle PN25		Tipo: Paso Recto
GGG40 PN25 - BRIDAS		
Especificaciones		
Material	Fundición Nodular EN-GJS-400-18-LT	
Asiento	Acero inoxidable X12 Cr 13	
Disco	Acero inoxidable X12 Cr 13	
Fuelle	X6 Cr Ni Mo Ti 17.12.2	
Conexiones	Bridas según EN 1092-1/2	
Estanqueidad	Clase A según EN 12266-1	
Distancia entre caras	EN 558-1 Serie 1	
Inspección y Pruebas	EN 12266-1	
Certificados	PED 97/23/EC para DN ≥ 32	



• Otras ejecuciones especiales (p.ej. con cono de regulación) bajo demanda

Componentes		
Pos.	Denominación	Material
1	Cuerpo	EN-GJS-400-18-LT
2	Asiento	X12 Cr 13 (1.4006)
3	Tapa	EN-GJS400-18-LT
4	Husillo	X20 Cr 13 (1.4021)
5	Volante	Acero
6	Prensaestopas	11 S Mn Pb 30
7	Obturador	X20 Cr 13 (1.4021)
8	Fuelle	X6 Cr Ni Mo Ti 17.12.2
9	Camisa	11 S Mn Pb 30
10	Empaquetadura	Grafito
11	Junta cuerpo-tapa	Grafito + Cr Ni St
12	Tornillo hexagonal	A2 70

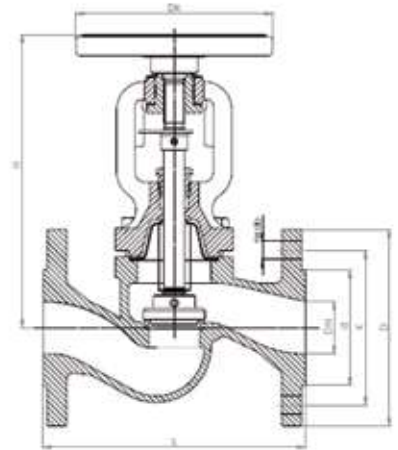

Válvula de Fuelle GGG40/13%Cr PN25 RF DN-15/200 Paso Recto

Código	Dimensiones (mm.)												
	DN	D	d	K	PN25						Regulación		
					n x do	Dk	h	L	H	Kvs	kg	Kvs	kg
010114310130025	15	95	46	65	4 x 14	125	5	130	178	5.9	3.2	3.4	3.2
010114310130026	20	105	56	75	4 x 14	125	5	150	178	7.4	3.9	6.3	3.9
010114310130027	25	115	65	85	4 x 14	125	7	160	193	13.0	4.6	9.4	5.0
010114310130028	32	140	76	100	4 x 19	125	8	180	201	18.0	6.5	16.0	6.7
010114310130029	40	150	84	110	4 x 19	150	10	200	224	30.0	9.0	26.0	9.3
010114310130030	50	165	99	125	4 x 19	150	13	230	228	41.0	11.0	40.0	11.5
010114310130031	65	185	118	145	8 x 19	175	17	290	270	79.0	15.8	70.0	16.3
010114310130032	80	200	132	160	8 x 19	200	20	310	295	115	20.5	106	21.4
010114310130033	100	235	156	190	8 x 23	250	25	350	321	181	35.0	170	36.0
-	125	270	184	220	8 x 28	300	32	400	388	225	49.0	245	51.5
-	150	300	211	250	8 x 28	400	38	480	448	364	76.0	360	78.0
-	200	360	274	310	12 x 28	500	50	600	575	725	130.5	-	130.5

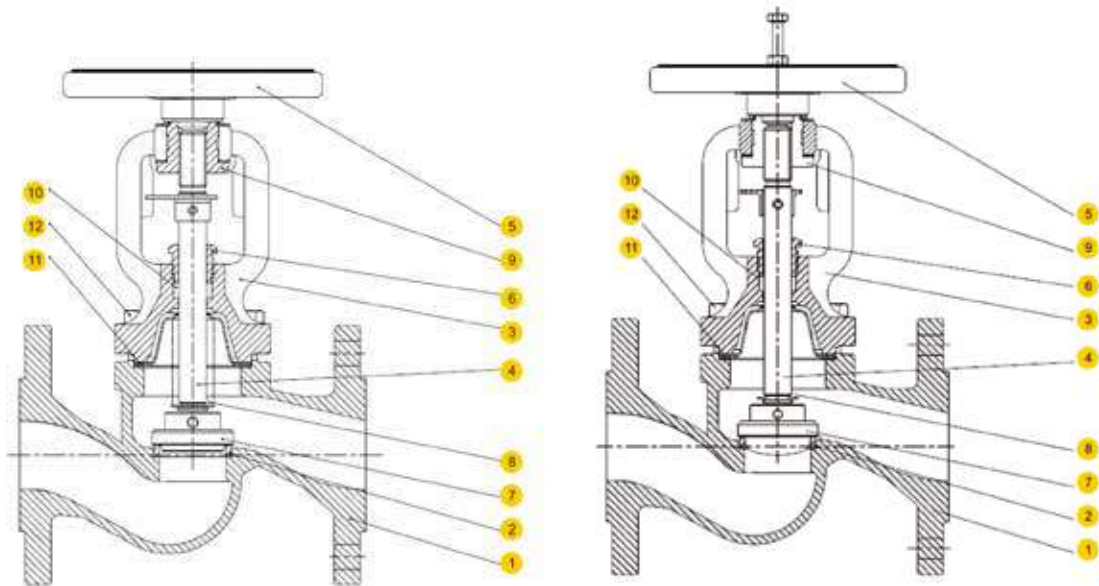

MODELO ESTÁNDAR

CON DISCO DE REGULACIÓN

Gráfico Presión / Temperatura

Condiciones de trabajo admisibles
Fundición Nodular PN25

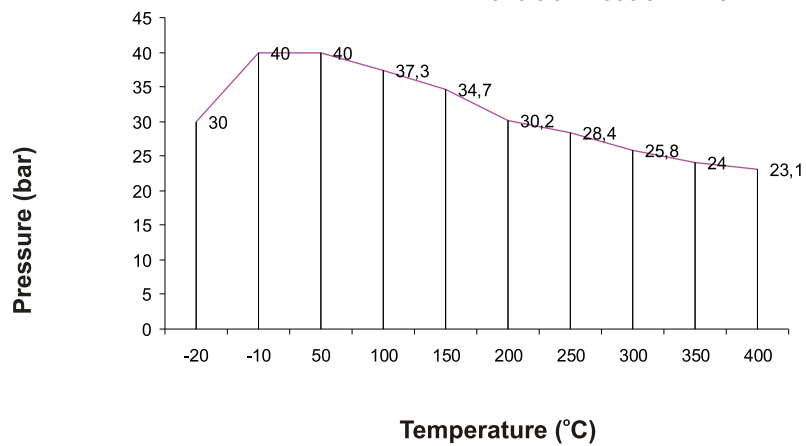

VÁLVULAS DE FUELLE

GLOBO TIPO FUELLE ACERO CARBONO PN40 PASO RECTO



RK-Z Fuelle PN40		Tipo: Paso Recto
GP 240GH PN40 - BRIDAS		
Especificaciones		
Material	Acero fundido GP 240GH	
Tapa	Acero fundido GP 240GH	
Disco	Acero inoxidable X20 Cr 13	
Fuelle	X6 Cr Ni Ti 18.10	
Conexiones	Bridas según EN 1092-1/2	
Estanqueidad	Clase A según EN 12266-1	
Distancia entre caras	EN 558-1 Serie 1	
Inspección y Pruebas	EN 12266-1	
Certificados	PED 97/23/EC para DN ≥ 32	



• Otras ejecuciones especiales (p.ej. con **cono de regulación**) bajo demanda

Componentes		
Pos.	Denominación	Material
1	Cuerpo	GP 240 GH (1.0619)
2	Tapa	GP 240 GH (1.0619)
3	Husillo	X8 Cr Ni S 18.9 (1.4305)
4	Volante	Hierro fundido
5	Prensaestopas	11 S Mn Pb 30
6	Obturador	X20 Cr 13 (1.4021)
7	Fuelle	X6 Cr Ni Ti 18.10
8	Carnisa	11 S Mn Pb 30
9	Empaquetadura	Grafito
10	Junta cuerpo-tapa	Grafito + Cr Ni St
11	Tornillo y tuerca	A2 70

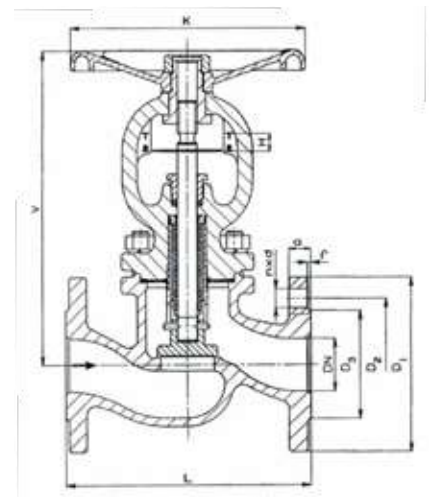

Válvula de Fuelle GSC25/13%Cr PN40 RF DN-15/150 Paso Recto

Código	Dimensiones (mm.)											
	DN	D1	D3	D2	n x d	K	H	L	V	a	Kvs (m³/h)	Peso (kg)
010114310130034	15	95	45	65	4 x 14	120	6	130	189	16	4.3	4.3
010114310130035	20	105	58	75	4 x 14	120	6	150	189	18	7.0	5.1
010114310130036	25	115	68	85	4 x 14	120	6	160	189	18	11.0	5.8
010114310130037	32	140	78	100	4 x 18	160	10	180	220	18	17.5	9.5
010114310130038	40	150	88	110	4 x 18	160	10	200	220	18	27.0	9.8
010114310130039	50	165	102	125	4 x 18	195	16.5	230	295	20	47.0	17.5
010114310130040	65	185	122	145	8 x 18	195	16.5	290	295	22	68.0	20.5
010114310130041	80	200	138	160	8 x 18	280	25	310	368	24	116	34.0
010114310130042	100	235	162	190	8 x 22	280	25	350	368	24	162	44.0
-	125	270	188	220	8 x 26	350	40	400	523	26	250	77.0
-	150	300	218	250	8 x 26	350	40	480	523	28	364	110.0

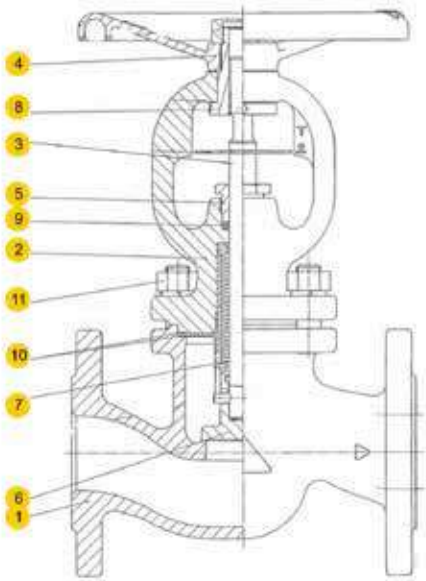

MODELO ESTÁNDAR

Gráfico Presión / Temperatura

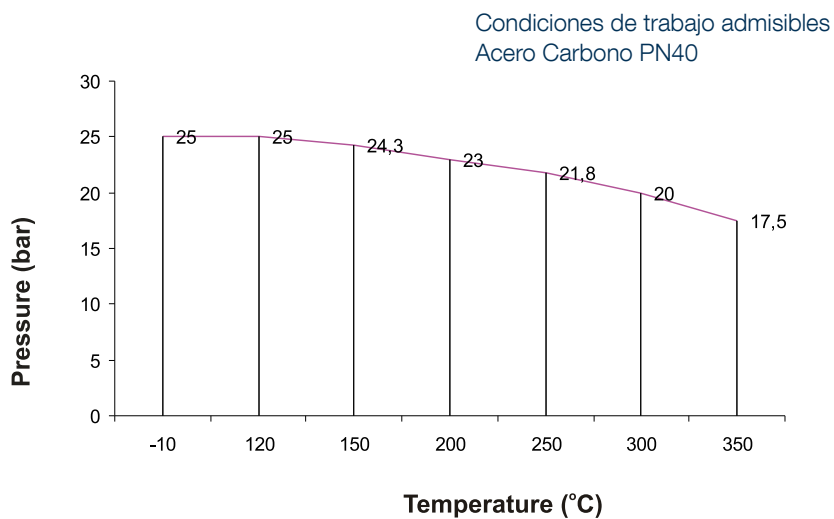

VÁLVULAS DE FUELLE

GLOBO TIPO FUELLE HIERRO FUNDIDO PN16 PASO ANGULAR

RK-Z Fuelle PN16		Tipo: Paso Angular
GG25 PN16 - BRIDAS		
Especificaciones		
Material	Hierro Fundido EN-GJL-250	
Asiento	Acero inoxidable X12 Cr 13	
Disco	Acero inoxidable X20 Cr 13	
Fuelle	X6 Cr Ni Mo Ti 17.12.2	
Conexiones	Bridas según EN 1092-2	
Estanqueidad	Clase A según EN 12266-1	
Distancia entre caras	EN 558-1 Serie 1	
Inspección y Pruebas	EN 12266-1	
Certificados	PED 97/23/EC para DN ≥ 32	



• Otras ejecuciones especiales (p.ej. con **cono de regulación**) bajo demanda



Componentes		
Pos.	Denominación	Material
1	Cuerpo	EN-GJL-250
2	Asiento	X12 Cr 13 (1.4006)
3	Tapa	EN-GJS400-18-LT
4	Husillo	X20 Cr 13 (1.4021)
5	Volante	Acero
6	Prensaestopas	11 S Mn Pb 30
7	Obturador	X20 Cr 13 (1.4021)
8	Fuelle	X6 Cr Ni Mo Ti 17.12.2
9	Camisa	11 S Mn Pb 30
10	Empaquetadura	Grafito
11	Junta cuerpo-tapa	Grafito + Cr Ni St
12	Tornillo hexagonal	8.8

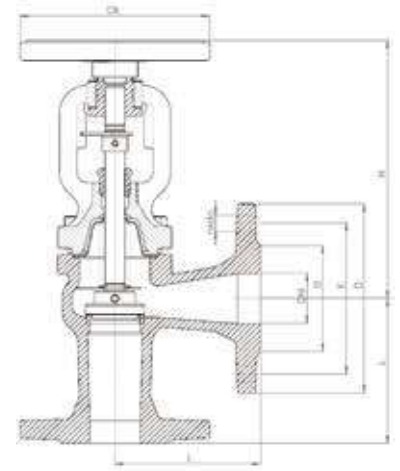

Válvula de Fuelle GG25/13%Cr PN16 RF DN-15/250 Paso Angular

Código	Dimensiones (mm.)										
	DN	D	d	K	n x do	Dk	L	H	Kvs	kg	Reg. kg
	15	95	46	65	4 x 14	125	90	181	7.2	3.2	3.2
	20	105	56	75	4 x 14	125	95	178	9.2	3.7	3.9
	25	115	65	85	4 x 14	125	100	195	16.0	4.9	5.0
	32	140	76	100	4 x 19	125	105	188	22.0	6.5	6.7
	40	150	84	110	4 x 19	150	115	205	37.0	8.8	9.1
	50	165	99	125	4 x 19	150	125	211	51.0	9.7	10.2
	65	185	118	145	4 x 19	178	145	242	98.5	13.8	14.3
	80	200	132	160	8 x 19	200	155	251	143	18.0	18.9
	100	220	156	180	8 x 19	250	175	307	226	31.0	33.0
	125	250	184	210	8 x 19	300	200	337	291	44.0	46.5
	150	285	211	240	8 x 23	400	225	366	455	69.0	71.0
	200	340	266	295	12 x 23	500	275	493	625	110.5	-
	250	405	310	355	12 x 28	500	325	531	-	-	-

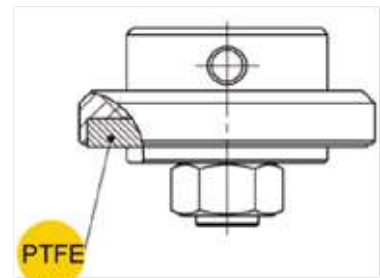
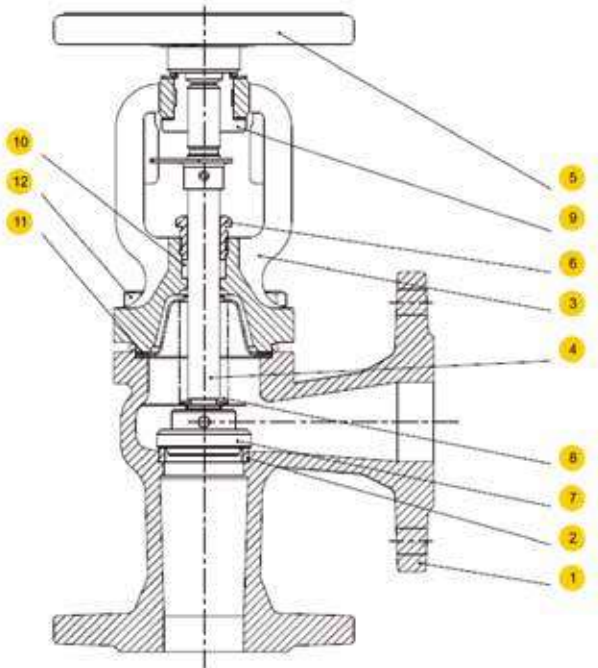

MODELO ESTÁNDAR

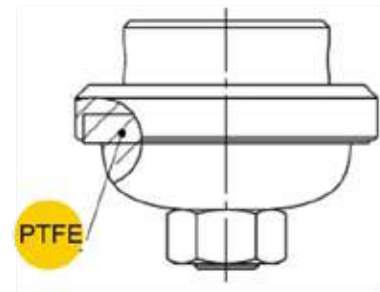

CON DISCO DE REGULACIÓN

Gráfico Presión / Temperatura

Condiciones de trabajo admisibles
HIERRO FUNDIDO PN16

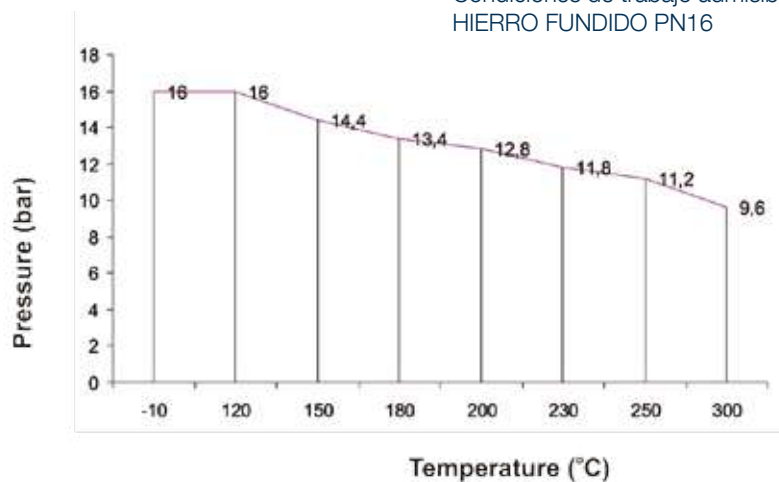

VÁLVULAS DE FUELLE

GLOBO TIPO FUELLE FUNDICIÓN NODULAR PN16 PASO ANGULAR

RK-Z Fuelle PN16		Tipo: Paso Angular
GG25 PN16 - BRIDAS		
Especificaciones		
Material	Fundición Nodular EN-GJS-400-18-LT	
Asiento	Acero inoxidable X12 Cr 13	
Disco	Acero inoxidable X20 Cr 13	
Fuelle	X6 Cr Ni Mo Ti 17.12.2	
Conexiones	Bridas según EN 1092-2	
Estanqueidad	Clase A según EN 12266-1	
Distancia entre caras	EN 558-1 Serie 1	
Inspección y Pruebas	EN 12266-1	
Certificados	PED 97/23/EC para DN ≥ 32	



• Otras ejecuciones especiales (p.ej. con **cono de regulación**) bajo demanda



Componentes		
Pos.	Denominación	Material
1	Cuerpo	EN-GJS-400-18-LT
2	Asiento	X12 Cr 13 (1.4006)
3	Tapa	EN-GJS400-18-LT
4	Husillo	X20 Cr 13 (1.4021)
5	Volante	Acero
6	Prensaestopas	11 S Mn Pb 30
7	Obturador	X20 Cr 13 (1.4021)
8	Fuelle	X6 Cr Ni Mo Ti 17.12.2
9	Camisa	11 S Mn Pb 30
10	Empaquetadura	Grafito
11	Junta cuerpo-tapa	Grafito + Cr Ni St
12	Tornillo hexagonal	A2 70

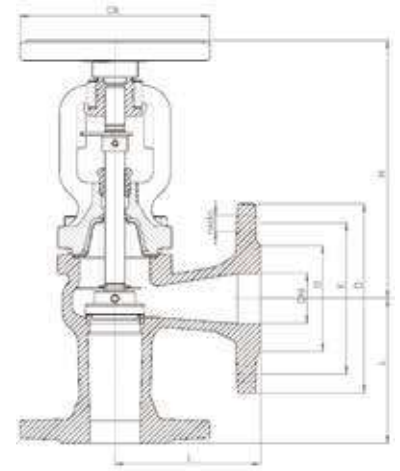

Válvula de Fuelle GGG40/13%Cr PN16 RF DN-15/200 Paso Angular

Código	Dimensiones (mm.)										
	DN	D	d	K	n x do	Dk	L	H	Kvs	kg	Reg. kg
	15	95	46	65	4 x 14	125	90	181	7.2	3.2	3.2
	20	105	56	75	4 x 14	125	95	178	9.2	3.7	3.9
	25	115	65	85	4 x 14	125	100	195	16.0	4.9	5.0
	32	140	76	100	4 x 19	125	105	188	22.0	6.5	6.7
	40	150	84	110	4 x 19	150	115	205	37.0	8.8	9.1
	50	165	99	125	4 x 19	150	125	211	51.0	9.7	10.2
	65	185	118	145	4 x 19	178	145	242	98.5	13.8	14.3
	80	200	132	160	8 x 19	200	155	251	143	18.0	18.9
	100	220	156	180	8 x 19	250	175	307	226	31.0	33.0
	125	250	184	210	8 x 19	300	200	337	291	44.0	46.5
	150	285	211	240	8 x 23	400	225	366	455	69.0	71.0
	200	340	266	295	12 x 23	500	275	493	625	110.5	-

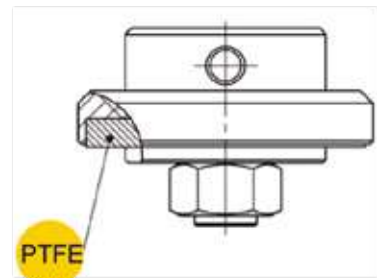
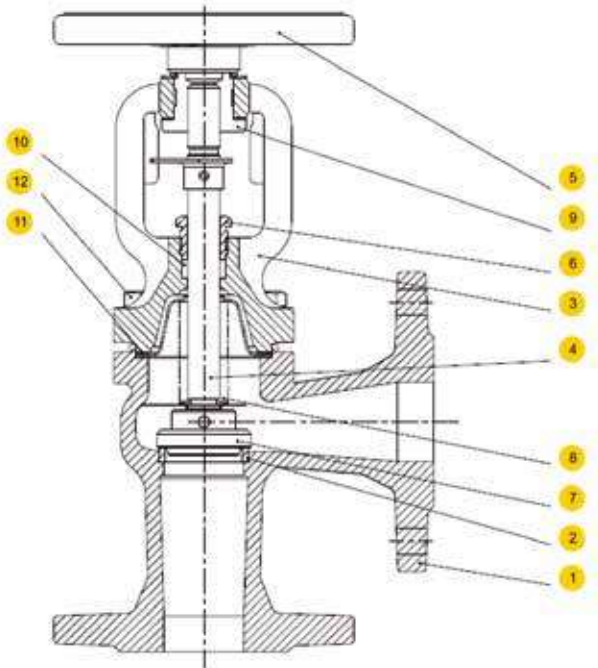

MODELO ESTÁNDAR

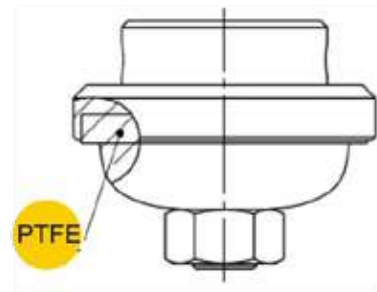

CON DISCO DE REGULACIÓN

Gráfico Presión / Temperatura

CONDICIONES DE TRABAJO ADMISIBLES
FUNDICIÓN NODULAR PN16

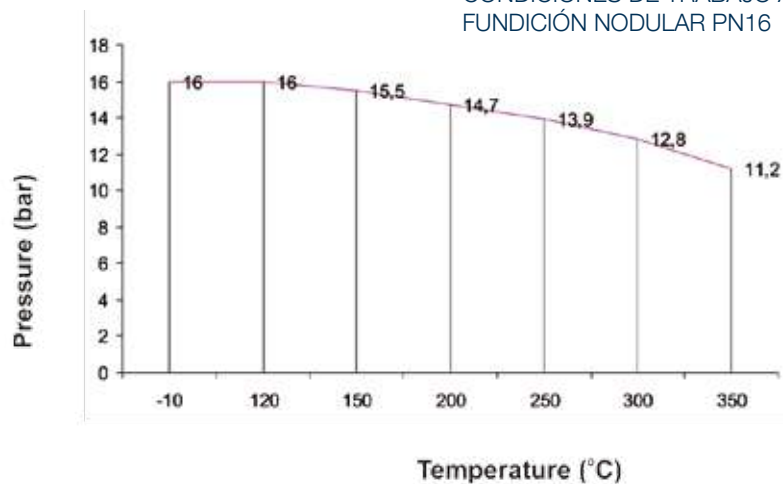

VÁLVULAS DE FUELLE

GLOBO TIPO FUELLE FUNDICIÓN NODULAR PN25 PASO ANGULAR

RK-Z Fuelle PN25		Tipo: Paso Angular
GG25 PN25 - BRIDAS		
Especificaciones		
Material	Fundición Nodular EN-GJS-400-18-LT	
Asiento	Acero inoxidable X12 Cr 13	
Disco	Acero inoxidable X20 Cr 13	
Fuelle	X6 Cr Ni Mo Ti 17.12.2	
Conexiones	Bridas según EN 1092-2	
Estanqueidad	Clase A según EN 12266-1	
Distancia entre caras	EN 558-1 Serie 1	
Inspección y Pruebas	EN 12266-1	
Certificados	PED 97/23/EC para DN ≥ 32	



• Otras ejecuciones especiales (p.ej. con **cono de regulación**) bajo demanda



Componentes		
Pos.	Denominación	Material
1	Cuerpo	EN-GJS-400-18-LT
2	Asiento	X12 Cr 13 (1.4006)
3	Tapa	EN-GJS400-18-LT
4	Husillo	X20 Cr 13 (1.4021)
5	Volante	Acero
6	Prensaestopas	11 S Mn Pb 30
7	Obturador	X20 Cr 13 (1.4021)
8	Fuelle	X6 Cr Ni Mo Ti 17.12.2
9	Camisa	11 S Mn Pb 30
10	Empaquetadura	Grafito
11	Junta cuerpo-tapa	Grafito + Cr Ni St
12	Tornillo hexagonal	A2 70

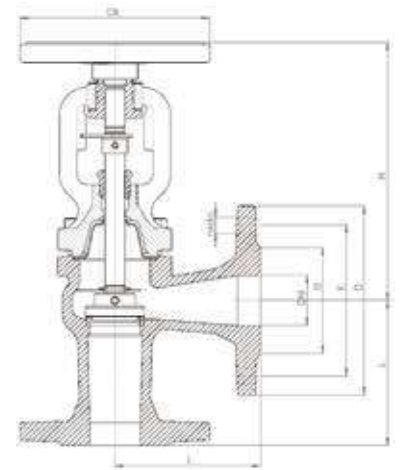

Válvula de Fuelle GGG40/13%Cr PN16 RF DN-15/80 Paso Angular

Código	Dimensiones (mm.)										
	DN	D	d	K	n x do	Dk	L	H	Kvs	kg	Reg. kg
	15	95	46	65	4 x 14	125	90	181	7.2	3.2	3.2
	20	105	56	75	4 x 14	125	95	178	9.2	3.7	3.9
	25	115	65	85	4 x 14	125	100	195	16.0	4.9	5.0
	32	140	76	100	4 x 19	125	105	188	22.0	6.5	6.7
	40	150	84	110	4 x 19	150	115	205	37.0	8.8	9.1
	50	165	99	125	4 x 19	150	125	211	51.0	9.7	10.2
	65	185	118	145	4 x 19	178	145	242	98.5	13.8	14.3
	80	200	132	160	8 x 19	200	155	251	143	18.0	18.9

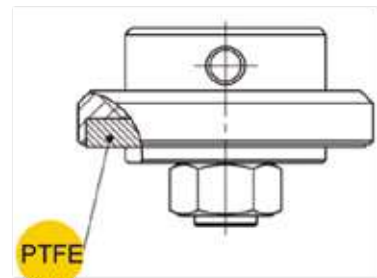
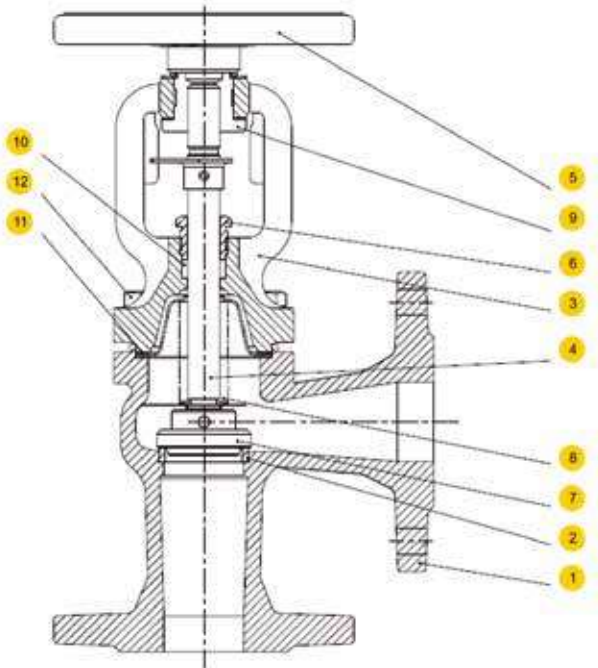

MODELO ESTÁNDAR

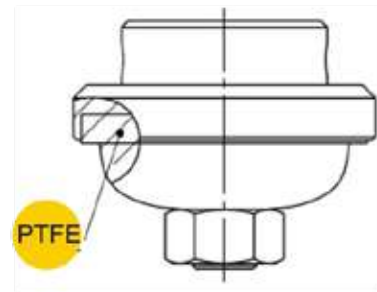

CON DISCO DE REGULACIÓN

Gráfico Presión / Temperatura

CONDICIONES DE TRABAJO ADMISIBLES
FUNDICIÓN NODULAR PN25

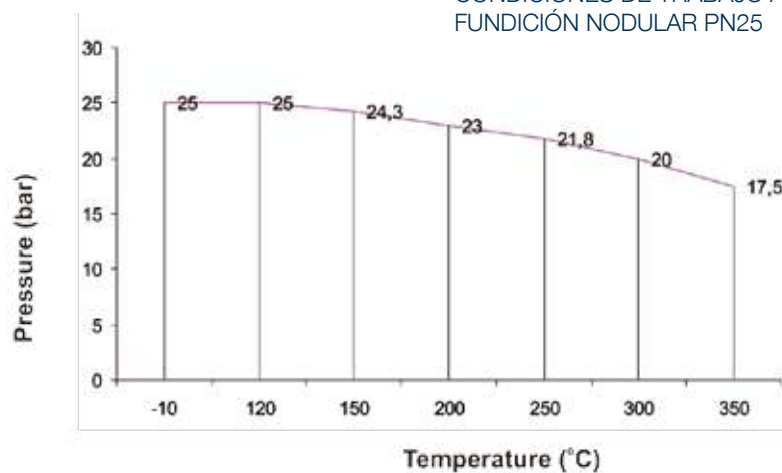

EJECUCIONES ESPECIALES

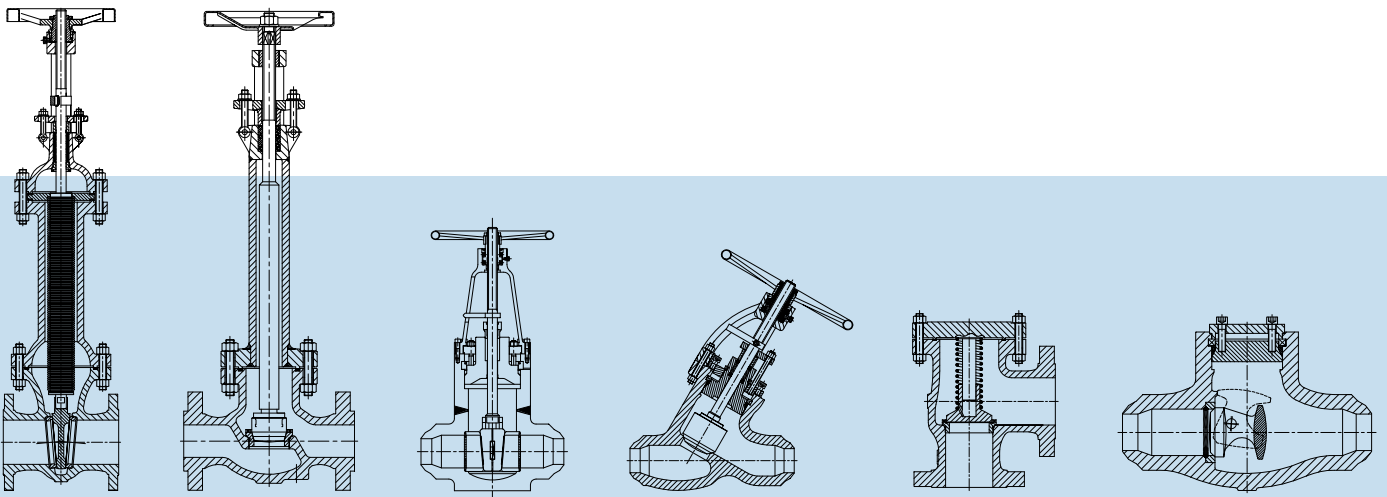

ANSI EJECUCIONES ESPECIALES

COMPUERTA CRIOGÉNICA ACERO INOX 150/1500LBS

COMPUERTA Acero inoxidable Fig. 45xEB		Tipo: Extended Bonnet
VÁLVULA COMPUERTA ACERO INOXIDABLE 150/1500LBS RF		
Materiales		
Cuerpo	Acero inoxidable	
Asiento	Acero inoxidable	
Obturador	Acero inoxidable	
Husillo	Acero inoxidable	
Empaquetadura	PTFE	
Junta cuerpo-tapa	PTFE	
Normas		
Diseño	API 600 y BS 1414	
Inspección y Pruebas	API 598, API 6D y BS 6755	
Distancia entre caras	ASME B16.10	

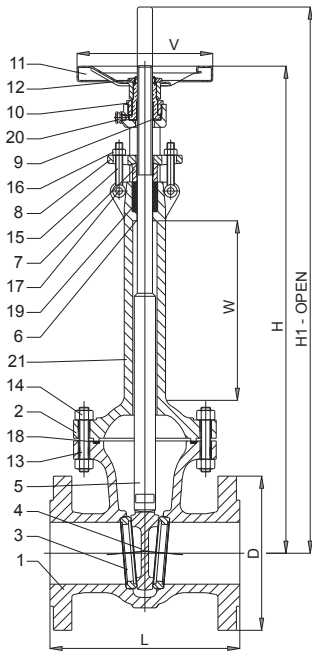
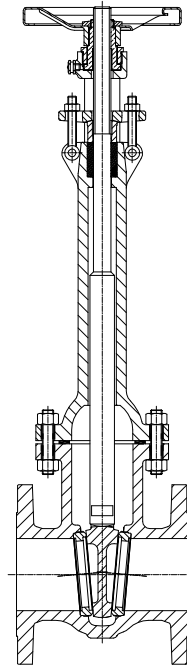

Pos.	Denominación	Componentes	
			Materiales (*)
1	Cuerpo	CF8	CF8M
2	Tapa	CF8	CF8M
3	Superficie asientos	F316	F316
4	Superficie cuña	F316	F316
5	Husillo	F316	F316
6	Cierre trasero (integral)	CF8	CF8M
7	Prensaestopas	F316	F316
8	Brida prensaestopas	F316	F316
9	Tuerca guía husillo	B148 9A	B149 9A
10	Tuerca puente	F316	F316
11	Volante	Acero	Acero
12	Tuerca volante	A105	A105
13	Tornillos	B8	B8
14	Tuercas	G8	G8
15	Tornillos de ojo	B8	B8
16	Tuercas	G8	G8
17	Pasador tornillo ojo	B8	B8
18	Junta cuerpo-tapa	PTFE	PTFE
19	Empaquetadura	PTFE	PTFE
20	Nipple engrase	F316	F316
21	Extensión	F304L	F316L

(*) Otros materiales bajo demanda

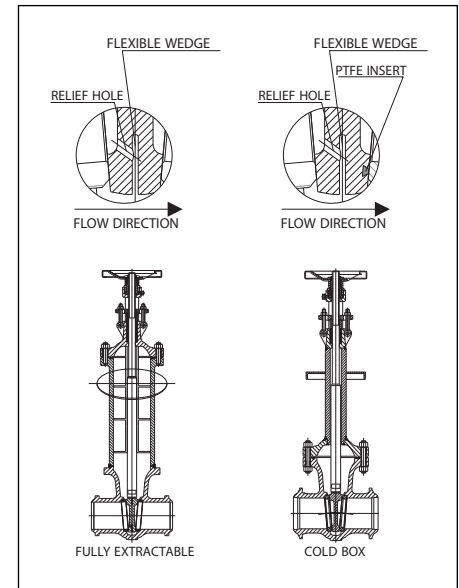

OPCIONES

FIG. 450EB - COMPUERTA CRIOGÉNICA CF8M/316 150LBS RF H. EXT.

Código	DN	L (RF)	L (BW)	D	V	W	H	H1
-	2"	178	216	152	200	200	550	600
-	2.1/2"	191	241	178	200	200	620	690
-	3"	203	282	191	225	300	730	810
-	4"	229	305	229	250	300	770	870
-	5"	254	381	254	250	300	860	990
-	6"	267	403	279	300	300	900	1050
-	8"	292	419	343	400	300	1075	1280
-	10"	330	457	406	500	300	1390	1650
-	12"	356	502	483	500	300	1540	1850
-	14"	381	571	533	600	300	1600	1950
-	16"	406	610	597	600	300	1800	2200
-	18"	432	660	635	700	300	1950	2550
-	20"	457	711	699	700	300	2100	2800
-	24"	508	813	813	800	300	2500	3400

FIG. 451EB - COMPUERTA CRIOGÉNICA CF8M/316 300LBS RF H. EXT.

Código	DN	L (RF/BW)	L (RTJ)	D	V	W	H	H1
-	2"	216	232	165	200	200	600	650
-	2.1/2"	241	257	191	200	200	630	700
-	3"	282	298	210	225	300	800	880
-	4"	305	321	254	250	300	830	930
-	5"	381	397	279	300	300	920	1045
-	6"	403	419	318	400	300	1030	1180
-	8"	419	435	381	500	300	1210	1280
-	10"	457	473	445	500	300	1410	1660
-	12"	502	518	521	600	300	1540	1840
-	14"	762	778	584	600	300	1700	2050
-	16"	838	854	648	700	300	1880	2280
-	18"	914	930	711	700	300	2000	2150
-	20"	991	1010	775	800	300	2200	2400
-	24"	1143	1165	914	900	300	2600	2750

FIG. 452EB - COMPUERTA CRIOGÉNICA CF8M/316 600LBS RF H. EXT.

Código	DN	L (RF/BW)	L (RTJ)	D	V	W	H	H1
-	2"	292	295	165	200	200	640	700
-	3"	356	359	210	250	300	840	920
-	4"	432	435	273	400	300	850	950
-	6"	559	562	356	500	300	1100	1250
-	8"	660	663	419	600	300	1260	1460
-	10"	787	791	508	700	300	1455	1710
-	12"	838	841	559	700	300	1620	1930
-	14"	889	892	603	800	300	1780	2130
-	16"	991	994	686	900	300	1980	2400
-	18"	1092	1095	743	1000	300	2130	2580
-	20"	1194	1200	813	1600	300	2230	2730
-	24"	1397	1407	940	Reductor	300	2460	3100

FIG. 453EB - COMPUERTA CRIOGÉNICA CF8M/316 900LBS RF H. EXT.

Código	DN	L (RF/BW)	L (RTJ)	D	V	W	H	H1
-	2"	368	371	216	250	200	650	700
-	3"	381	384	241	300	300	900	980
-	4"	457	460	292	400	300	970	1070
-	6"	610	613	381	600	300	1190	1350
-	8"	737	740	470	650	300	1414	1620
-	10"	838	841	546	700	300	1555	1820
-	12"	965	968	610	900	300	1739	2050
-	14"	1029	1038	641	1000	300	1885	2250
-	16"	1130	1140	705	Reductor	300	1939	2350
-	18"	1219	1232	787	Reductor	300	2135	2600
-	20"	1321	1334	857	Reductor	300	2270	2800
-	24"	1549	1568	1041	Reductor	300	2530	3150

FIG. 454EB - COMPUERTA CRIOGÉNICA CF8M/316 1500LBS RF H. EXT.

Código	DN	L (RF/BW)	L (RTJ)	D	V	W	H	H1
-	2"	368	371	216	250	200	650	700
-	3"	470	473	267	400	300	920	1000
-	4"	546	549	311	500	300	1060	1170
-	6"	705	711	394	600	300	1230	1390
-	8"	832	842	483	700	300	1448	1660
-	10"	991	1000	584	900	300	1555	1820
-	12"	1130	1146	673	1600	300	1739	2050
-	14"	1257	1276	749	Reductor	300	1885	2250
-	16"	1384	1407	826	Reductor	300	1939	2350
-	18"	1537	1559	914	Reductor	300	2135	2600
-	20"	1664	1686	984	Reductor	300	2270	2800
-	24"	1943	1972	1168	Reductor	300	2530	3150

ANSI EJECUCIONES ESPECIALES

COMPUERTA FUELLE ACERO CARBONO 150/1500LBS

COMPUERTA Acero carbono Fig. 45xSO		Tipo: Fuelle
VÁLVULA COMPUERTA ACERO CARBONO 150/1500LBS RF		
Materiales		
Cuerpo	Acero carbono	
Asiento	Acero inoxidable	
Fuelle	Acero inoxidable F321	
Husillo	Acero inoxidable	
Empaquetadura	Grafito	
Junta cuerpo-tapa	Acero inox. / Grafito	
Normas		
Diseño	API 600 y BS 1414	
Inspección y Pruebas	API 598, API 6D y BS 6755	
Distancia entre caras	ASME B16.10	

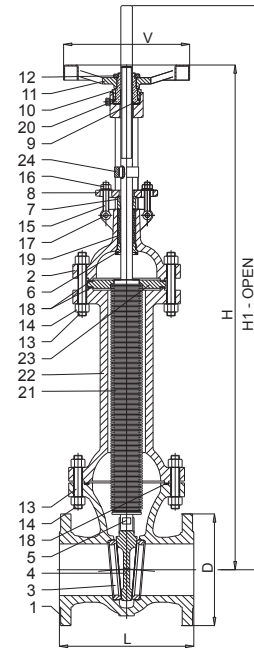

Pos.	Denominación	Componentes									
		Materiales estándar (*)									
1	Cuerpo	WCB	LCB	WC6	C5	C12	CF8	C8FC	CF8M	CF3M	
2	Tapa	WCB	LCB	WC6	C5	C12	CF8	CF8C	CF8M	CF3M	
3	Superficie asientos	F6a	F6a	F6a	F6a	F6a	F304	F321	F316	F316L	
4	Superficie cuña	F6a	F6a	F6a	F6a	F6a	F304	F321	F316	F316L	
5	Husillo	F6a	F6a	F6a	F6a	F6a	F304	F321	F316	F316L	
6	Cierre trasero	F6a	F6a	F6a	F6a	F6a	F304	F321	F316	F316L	
7	Prensaestopas	F6a	F6a	F6a	F6a	F6a	F304	F321	F316	F316L	
8	Brida prensaestopas	A105	F316	F316	F316	F316	F316	F316	F316	F316L	
9	Tuerca guía husillo	B148 9A	B148 9A	F. Nodular	F. Nodular	F. Nodular	B148 9A	B148 9A	B148 9A	B148 9A	
10	Tuerca puente	A105	A105	A105	A105	A105	F316	F316	F316	F316L	
11	Volante	Acero									
12	Tuerca volante	A105									
13	Tornillos	B7	L7	B16	B16	B16	B8	B8	B8	B8	
14	Tuercas	2H	G4	G4	G4	G4	G8	G8	G8	G8	
15	Tornillos de ojo	B7	B7	B8	B8	B8	B8	B8	B8	B8	
16	Tuercas	2H	2H	2H	2H	2H	G8	G8	G8	G8	
17	Pasador tornillo ojo	B7	B7	B7	B7	B7	B8	B8	B8	B8	
18	Junta cuerpo-tapa	Acero inox. / Grafito									
19	Empaquetadura	Grafito									
20	Nipple engrase	A105									
21	Fuelle	A182 F321									
22	Extensión	A105	LF2	F11	F5	F9	F304L	F347	F316L	F316L	
23	Brida fuelle	A182 F321									
24	Dispositivo anti-rotación	F6a	F6a	F6a	F6a	F6a	F321	F321	F316	F316L	

(*) Otros materiales bajo demanda

FIG. 450SO - COMPUERTA FUELLE WCB/F6 150LBS RF H. EXT.

Código	DN	L (RF)	L (BW)	D	V	H	H1
-	2"	178	216	152	200	610	660
-	2.1/2"	191	241	178	200	675	740
-	3"	203	282	191	225	820	900
-	4"	229	305	229	250	940	1040
-	5"	254	381	254	250	1160	1290
-	6"	267	403	279	300	1530	1680
-	8"	292	419	343	400	1960	2160
-	10"	330	457	406	500	2350	2600
-	12"	356	502	483	500	2600	2900
-	14"	381	571	533	600	2980	3350
-	16"	406	610	597	600	3170	3570
-	18"	432	660	635	700	3550	4000
-	20"	457	711	699	700	4050	4550
-	24"	508	813	813	800	4650	5250

FIG. 451SO - COMPUERTA FUELLE WCB/F6 300LBS RF H. EXT.

Código	DN	L (RF)	L (BW)	D	V	H	H1
-	2"	216	232	165	200	600	650
-	2.1/2"	241	257	191	200	685	750
-	3"	282	298	210	225	765	840
-	4"	305	321	254	250	920	1020
-	5"	381	397	279	300	1070	1200
-	6"	403	419	318	400	1315	1465
-	8"	419	435	381	500	1700	1900
-	10"	457	473	445	500	2035	2285
-	12"	502	518	521	600	2395	2700
-	14"	762	778	584	600	2760	3110
-	16"	838	854	648	700	3135	4535
-	18"	914	930	711	700	3600	4050
-	20"	991	1010	775	800	4080	4580
-	24"	1143	1165	914	900	4795	5350

FIG. 452SO - COMPUERTA FUELLE WCB/F6 600LBS RF H. EXT.

Código	DN	L (RF/BW)	L (RTJ)	D	V	H	H1
-	2"	292	295	165	200	640	690
-	3"	356	359	210	250	805	880
-	4"	432	435	273	400	905	1010
-	6"	559	562	356	500	1360	1510
-	8"	660	663	419	600	1720	1920
-	10"	787	791	508	700	2120	2370
-	12"	838	841	559	900	2500	2800
-	14"	889	892	603	800	-	-
-	16"	991	994	686	900	-	-
-	18"	1092	1095	743	1000	-	-
-	20"	1194	1200	813	1600	-	-
-	24"	1397	1407	940	Reductor	-	-

FIG. 453SO - COMPUERTA FUELLE WCB/F6 900LBS RF H. EXT.

Código	DN	L (RF/BW)	L (RTJ)	D	V	H	H1
-	2"	368	371	216	250	-	-
-	3"	381	384	241	300	-	-
-	4"	457	460	292	400	-	-
-	6"	610	613	381	600	-	-
-	8"	737	740	470	650	-	-
-	10"	838	841	546	700	-	-
-	12"	965	968	610	900	-	-
-	14"	1029	1038	641	1000	-	-
-	16"	1130	1140	705	Reductor	-	-

FIG. 454SO - COMPUERTA FUELLE WCB/F6 1500LBS RF H. EXT.

Código	DN	L (RF/BW)	L (RTJ)	D	V	H	H1
-	2"	368	371	216	250	-	-
-	3"	470	473	267	400	-	-
-	4"	546	549	311	500	-	-
-	6"	705	711	394	600	-	-
-	8"	832	842	483	700	-	-
-	10"	991	1000	584	900	-	-
-	12"	1130	1146	673	1600	-	-
-	14"	1257	1276	749	1600	-	-
-	16"	1384	1407	826	1600	-	-

ANSI EJECUCIONES ESPECIALES

COMPUERTA PRESSURE SEAL ACERO CARBONO 600/2500LBS

COMPUERTA Acero carbono Fig. P5x		Tipo: Pressure seal
VÁLVULA COMPUERTA ACERO CARBONO 600/2500LBS RF		
Materiales		
Cuerpo	Acero carbono	
Asiento	Acero inoxidable	
Obturador	Acero carbono stellitado	
Husillo	Acero inoxidable	
Empaquetadura	Grafito	
Junta cuerpo-tapa	Acero inox. / Grafito	
Normas		
Diseño	API 600 y ASME B16.34	
Inspección y Pruebas	API 598, API 6D y BS 6755	
Distancia entre caras	ASME B16.10	

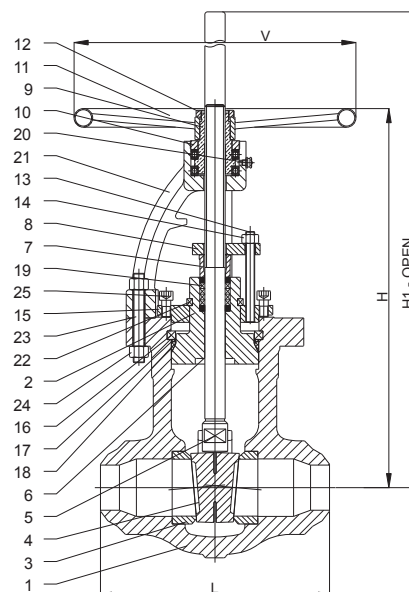

Pos.	Denominación	Componentes				
		Materiales estándar (*)				
1	Cuerpo	WCB	WC1	WC6	WC9	CF8M
2	Tapa	WCB	WC1	WC6	WC9	C8FM
3	Superficie asientos	A105 + HF	F6a + HF	F6a + HF	F6A + HF	F316 + HF
4	Superficie cuña	WCB + HF	WC1 + HF	WC6 + HF	WC9 + HF	CF8M + HF
5	Husillo	F6a	F6a	F6a	F6a	F316
6	Cierre trasero (integral)	Stellite®				
7	Prensaestopas	F6a	F6a	F6a	F6a	F316
8	Brida prensaestopas	A105	F316	F316	F316	F316
9	Tuerca guía husillo	B148 9A				
10	Tuerca puente	A105	A105	A105	A105	F316
11	Volante	Acero				
12	Tuerca volante	A105				
13	Tornillos	B7	B16	B16	B16	B8
14	Tuercas	2H	G4	G4	G4	G8
15	Brida retenedora	A105	A105	A105	A105	F316
16	Anillo segmentado	F6a	F6a	F6a	F6a	F316
17	Anillo espaciador	F6a	F6a	F6a	F6a	F316
18	Junta	Acero inoxidable / Grafito reforzado				
19	Empaquetadura	Anillos de Grafito y Anillos retén				
20	Nipple engrase	Acero				
21	Puente	WCB	WC1	WC6	WC9	CF8M
22	Anillo soporte segmentado	F6	F6	F6	F6	F316
23	Tornillo cuerpo-puente	B7	B16	B16	B16	B8
24	Tuerca cuerpo-puente	2H	G4	G4	G4	G8
25	Tornillos	B7	B16	B16	B16	B8

(*) Otros materiales bajo demanda

FIG. P52 - COMPUERTA PRESSURE SEAL WCB/F6 XU 600LBS RF H. EXT.

Código	DN	L (RF)	L (RTJ)	L (BW)	V	H	H1
-	2"	292	295	178	200	500	550
-	3"	356	359	254	250	550	630
-	4"	432	435	305	400	590	690
-	6"	559	562	457	500	840	990
-	8"	660	663	584	600	970	1170
-	10"	787	791	711	700	1160	1410
-	12"	838	841	813	Reductor	1300	1600
-	14"	889	892	889	Reductor	1500	1850
-	16"	991	994	991	Reductor	1780	2180
-	18"	1092	1095	1092	Reductor	2000	2450
-	20"	1194	1200	1194	Reductor	2150	2650
-	24"	1397	1407	1397	Reductor	2400	3000

FIG. P53 - COMPUERTA PRESSURE SEAL WCB/F6 XU 900LBS RF H. EXT.

Código	DN	L (RF)	L (RTJ)	L (BW)	V	H	H1
-	2"	368	371	216	250	500	550
-	3"	381	384	305	300	550	620
-	4"	457	460	356	400	590	690
-	6"	610	613	508	500	840	990
-	8"	737	740	660	Reductor	970	1170
-	10"	838	841	787	Reductor	1250	1500
-	12"	965	968	914	Reductor	1350	1650
-	14"	1029	1038	991	Reductor	1580	1930
-	16"	1130	1140	1092	Reductor	1900	2300
-	18"	1219	1232	1143	Reductor	2050	2600
-	20"	1321	1334	1245	Reductor	2200	2700
-	24"	1549	1568	1397	Reductor	2500	3100

FIG. P54 - COMPUERTA PRESSURE SEAL WCB/F6 XU 1500LBS RF H. EXT.

Código	DN	L (RF)	L (RTJ)	L (BW)	V	H	H1
-	2"	368	371	216	250	500	550
-	3"	470	473	305	400	550	630
-	4"	546	549	406	600	590	690
-	6"	705	711	559	Reductor	840	990
-	8"	832	842	711	Reductor	970	1170
-	10"	991	1000	864	Reductor	1250	1500
-	12"	1130	1146	991	Reductor	1350	1700
-	14"	1257	1276	1067	Reductor	1780	2130
-	16"	1384	1407	1194	Reductor	2000	2400
-	18"	1537	1559	1346	Reductor	2200	2650
-	20"	1664	1686	1473	Reductor	2400	2900
-	24"	1943	1972	1943	Reductor	2600	3200

FIG. P55 - COMPUERTA PRESSURE SEAL WCB/F6 XU 2500LBS RF H. EXT.

Código	DN	L (RF)	L (RTJ)	L (BW)	V	H	H1
-	2"	451	454	279	300	500	550
-	3"	578	584	368	500	550	630
-	4"	673	683	457	700	600	690
-	6"	914	927	610	Reductor	860	1010
-	8"	1022	1038	762	Reductor	1000	1200
-	10"	1270	1292	914	Reductor	1330	1580
-	12"	1422	1445	1041	Reductor	1480	1780
-	14"	-	-	1118	Reductor	1860	2210
-	16"	-	-	1245	Reductor	2090	2490
-	18"	-	-	1397	Reductor	2350	2800
-	20"	-	-	1524	Reductor	2650	3150
-	24"	-	-	1676	Reductor	2800	3400

VARIANTE - COMPUERTA PRESSURE SEAL ASIENTOS PARALELOS

El diseño de Válvula de compuerta de Asientos paralelos con muelles precargados permite utilizar un actuador con un menor par —reduciendo costes—, gracias a la capacidad de los discos de auto-alinearse y de mantener permanentemente en contacto los discos con los anillos del asiento durante el sellado inicial, lo cual elimina vibraciones. Los discos, al ser intercambiables, facilitan el mantenimiento y eliminan la necesidad de ajustar los asientos a los discos. Un tope integral interno asegura una protección en válvulas actuadas, sirviendo de guía y posicionando correctamente los discos en posición abierta y cerrada.

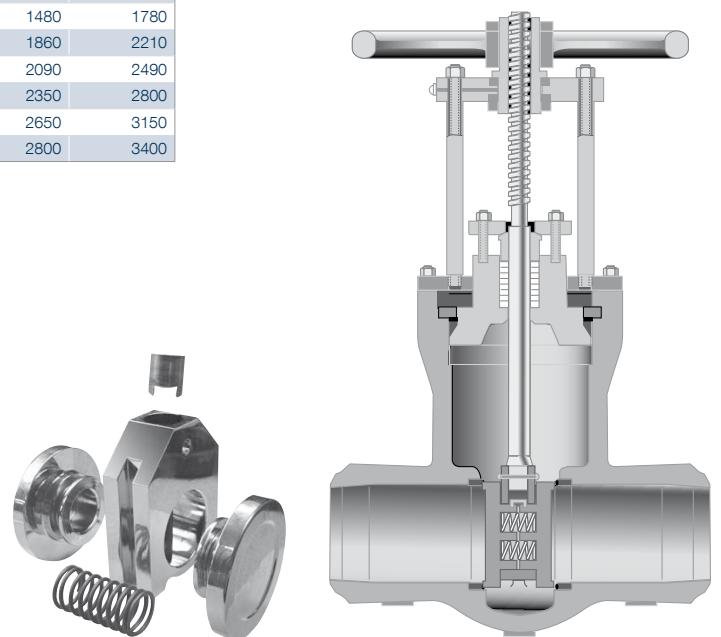

ANSI EJECUCIONES ESPECIALES

COMPUERTA THROUGH CONDUIT ACERO CARBONO 150/1500LBS

COMPUERTA Acero carbono Fig. T5x		Tipo: Through Conduit
VÁLVULA COMPUERTA ACERO CARBONO 150/1500LBS RF		
Materiales		
Cuerpo	Acero carbono	
Asiento	Acero carbono	
Obturador	Acero carbono	
Husillo	Acero inoxidable	
Empaquetadura	Viton®	
Junta cuerpo-tapa	Buna	
Normas		
Diseño	API 6D, ASME B16.34, ASME B31.3	
Inspección y Pruebas	API 598, API 6D y BS 6755	
Distancia entre caras	API 6D	

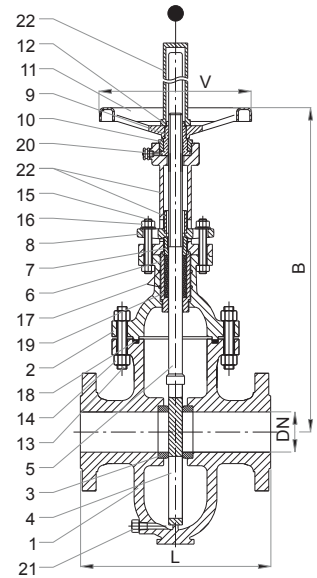

Componentes			
Pos.	Denominación	Materiales (*)	
1	Cuerpo	A216 WCB	A352 LCC
2	Tapa	A216 WCB	A352 LCC
3	Superficie asientos	A105	A350 LF2
4	Superficie cuña	A516 Gr. 70	A537 CL1
5	Husillo	AISI 410	
6	Caja prensaestopas	A105	A350 LF2
7	Prensaestopas	A105	A350 LF2
8	Brida prensaestopas	A105	A350 LF2
9	Tuerca guía husillo	B148 9A	B148 9A
10	Tuerca puente	A105	A105
11	Volante	Acero	Acero
12	Tuerca volante	A105	A105
13	Tornillos	B7	L7
14	Tuercas	2H	G4
15	Tornillos de ojo	B7	L7
16	Tuercas	2H	G4
17	O-rings	Buna	Buna / Viton®
18	Junta cuerpo-tapa	Buna	Buna / Viton®
19	Empaquetadura	Viton®	
20	Nipple engrase	A105	A105
21	Tapón	A105	A350 LF2
22	Protección husillo	A105	A105

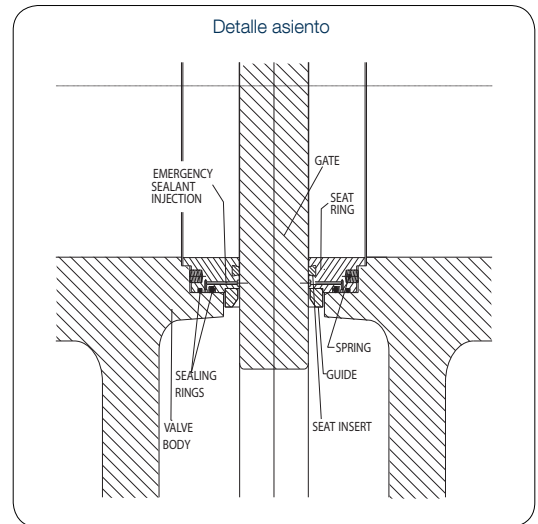

(*) Otros materiales bajo demanda

FIG. T50 - COMPUERTA THROUGH CONDUIT WCB/A105 150LBS RF H. EXT.

DN	3"	4"	6"	8"	10"	12"	14"	16"	18"	20"	22"	24"	26"	28"	30"	32"	34"	36"	40"
L (RF)	203	229	267	292	330	356	381	406	432	457	508	508	559	610	650	711	762	800	914
L (BW)	282	305	403	419	457	502	572	610	660	711	762	813	864	914	914	965	1016	1016	1118
DN	76	102	152	203	254	305	337	387	439	489	540	591	635	686	737	782	831	876	927
V	300	300	300	450	600	600	600	600	600	800	Reduc.	Reduc.	Reduc.	Reduc.	Reduc.	Reduc.	Reduc.	Reduc.	Reduc.
A	215	270	345	433	520	584	630	722	785	860	974	1050	1160	1210	1295	1360	1480	1540	1700
B	505	530	665	820	975	1100	1190	1345	1480	1610	1800	1880	2110	2190	2330	2530	2660	2800	3160

FIG. T51 - COMPUERTA THROUGH CONDUIT WCB/A105 300LBS RF H. EXT.

DN	3"	4"	6"	8"	10"	12"	14"	16"	18"	20"	22"	24"	26"	28"	30"	32"	34"	36"	40"
L (RF/BW)	282	305	403	419	457	502	762	838	914	991	1092	1143	1245	1346	1397	1524	1626	1727	1930
L (RTJ)	298	321	419	435	473	518	778	854	930	1010	1114	1165	1270	1372	1422	1552	1654	1755	-
DN	76	102	152	203	254	305	337	387	439	489	540	591	635	686	737	782	831	876	978
V	300	300	300	300	600	600	600	800	800	1100	Reduc.	Reduc.	Reduc.	Reduc.	Reduc.	Reduc.	Reduc.	Reduc.	Reduc.
A	260	299	355	430	507	580	661	747	817	897	982	1037	1142	1252	1335	1395	1490	1570	1700
B	490	533	655	920	980	1110	1200	1360	1480	1650	1810	1930	2160	2230	2400	2570	2710	2820	3200

FIG. T52 - COMPUERTA THROUGH CONDUIT WCB/A105 600LBS RF H. EXT.

DN	3"	4"	6"	8"	10"	12"	14"	16"	18"	20"	22"	24"	26"	28"	30"	32"	34"	36"	40"
L (RF/BW)	356	432	559	660	787	838	889	991	1092	1194	1295	1397	1448	1549	1651	1778	1930	2083	2286
L (RTJ)	359	435	562	663	791	841	892	994	1095	1200	1305	1407	1461	1562	1664	1794	1946	2099	-
DN	76	102	152	203	254	305	337	387	439	489	540	591	635	686	737	782	831	876	978
V	300	300	300	300	600	600	600	800	800	1100	Reduc.	Reduc.	Reduc.	Reduc.	Reduc.	Reduc.	Reduc.	Reduc.	Reduc.
A	212	307	405	435	510	590	630	725	810	930	995	1085	1170	1280	1350	1400	1490	1580	1710
B	485	530	690	860	980	1160	1200	1375	1500	1700	1900	2100	2200	2300	2400	2650	2750	2900	3200

FIG. T53 - COMPUERTA THROUGH CONDUIT WCB/A105 900LBS RF H. EXT.

DN	3"	4"	6"	8"	10"	12"	14"	16"	18"	20"	22"	24"	26"
L (RF/BW)	381	457	610	737	838	965	1029	1130	1219	1321	-	1549	-
L (RTJ)	384	460	613	740	841	968	1038	1140	1232	1334	-	1568	-
DN	76	102	152	203	254	305	337	387	439	489	540	591	-
V	300	300	300	300	600	600	Reduc.	Reduc.	Reduc.	Reduc.	Reduc.	Reduc.	Reduc.
A	207	252	337	422	514	590	637	727	917	987	-	1212	-
B	515	541	660	850	998	1200	1300	1400	1600	1800	-	2100	-

FIG. T54 - COMPUERTA THROUGH CONDUIT WCB/A105 1500LBS RF H. EXT.

DN	3"	4"	6"	8"	10"	12"	14"	16"	18"	20"	22"	24"	26"
L (RF/BW)	470	546	705	832	991	1130	1257	1384	1537	1664	-	1943	-
L (RTJ)	500	549	711	841	1000	1146	1276	1407	1559	1686	-	1972	-
DN	76	102	152	203	254	305	337	387	439	489	540	591	-
V	300	300	300	300	600	600	Reduc.	Reduc.	Reduc.	Reduc.	Reduc.	Reduc.	Reduc.
A	254	271	357	437	520	532	661	747	817	897	-	1037	-
B	588	661	715	860	1010	1200	1400	1500	1600	1800	-	2200	-

ANSI EJECUCIONES ESPECIALES

GLOBO TIPO 'Y' 150/1500LBS

GLOBO Acero carbono Fig. 46xY		Tipo: Asiento inclinado
VÁLVULA GLOBO 'Y' 150/1500LBS RF		
Materiales		
Cuerpo	Acero carbono	
Asiento	Acero inoxidable	
Obturador	Acero inoxidable	
Husillo	Acero inoxidable	
Empaquetadura	Grafito	
Junta cuerpo-tapa	Acero inox. / Grafito o RTJ	
Normas		
Diseño	BS 1873, ASME B16.34. Espesor de pared API 600	
Inspección y Pruebas	API 598, API 6D y BS 6755	
Distancia entre caras	ASME B16.10	

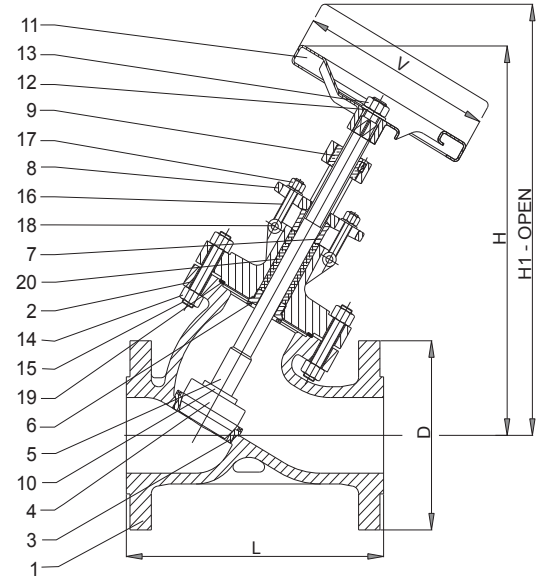

Pos.	Denominación	Componentes									
		Materiales estándar (*)									
1	Cuerpo	WCB	LCB	WC6	C5	C12	CF8	C8FC	CF8M	CF3M	
2	Tapa	WCB	LCB	WC6	C5	C12	CF8	CF8C	CF8M	CF3M	
3	Superficie asientos	F6a	F6a	F6a	F6a	F6a	F304	F321	F316	F316L	
4	Superficie obturador	F6a	F6a	F6a	F6a	F6a	F304	F321	F316	F316L	
5	Husillo	F6a	F6a	F6a	F6a	F6a	F304	F321	F316	F316L	
6	Cierre trasero	F6a	F6a	F6a	F6a	F6a	F304	F321	F316	F316	
7	Prensaestopas	F6a	F6a	F6a	F6a	F6a	F304	F321	F316	F316	
8	Brida prensaestopas	A105	F316	F316	F316	F316	F316	F316	F316	F316	
9	Tuerca guía husillo	B148 9A	B148 9A	F. Nodular	F. Nodular	F. Nodular	B148 9A	B148 9A	B148 9A	B148 9A	
10	Tuerca puente	F6a	F6a	F6a	F6a	F6a	F304	F321	F316	F316L	
11	Volante	Acero									
12	Placa	A105									
13	Tuerca volante	A105									
14	Tornillos	B7	L7	B16	B16	B16	B8	B8	B8	B8	
15	Tuercas	2H	G4	G4	G4	G4	G8	G8	G8	G8	
16	Tornillos de ojo	B7	B7	B8	B8	B8	B8	B8	B8	B8	
17	Tuercas	2H	2H	2H	2H	2H	G8	G8	G8	G8	
18	Pasador tornillo ojo	B7	B7	B7	B7	B7	B8	B8	B8	B8	
19	Junta	Acero inox. / Grafito o RTJ									
20	Empaquetadura	Grafito									

(*) Otros materiales bajo demanda

FIG. 460Y - GLOBO 'Y' WCB/F6 150LBS RF H. EXT.

DN	2"	2.1/2"	3"	4"	5"	6"	8"	10"	12"	14"	16"
L (RF/BW)	203	216	241	292	356	406	495	622	699	787	914
L (RTJ)	216	219	254	305	368	419	508	635	711	800	927
D	152	178	191	229	254	279	343	406	483	533	597
V	200	200	225	250	300	300	400*	500*	500*	800*	800*
H	320	350	380	440	480	560	680	750	860	930	1250
H1	380	430	470	550	615	720	890	1010	1170	1040	1380

(*) Se recomienda reductor manual

FIG. 461Y - GLOBO 'Y' WCB/F6 300LBS RF H. EXT.

DN	2"	2.1/2"	3"	4"	5"	6"	8"	10"	12"	14"	16"
L (RF/BW)	267	292	318	356	400	445	559	622	711	838	864
L (RTJ)	282	308	333	371	416	460	575	638	727	854	879
D	165	191	210	254	279	318	381	445	521	584	648
V	200	225	225	300	300	400*	500*	600*	800*	1000*	1000*
H	390	400	410	430	570	680	800	850	1010	1150	1390
H1	410	420	435	520	615	735	860	930	1110	1270	1512

(*) Se recomienda reductor manual

FIG. 462Y - GLOBO 'Y' WCB/F6 600LBS RF H. EXT.

DN	2"	2.1/2"	3"	4"	5"	6"	8"	10"	12"	14"	16"
L (RF/BW)	292	330	356	432	508	559	660	787	838	889	991
L (RTJ)	295	333	359	435	511	562	663	790	841	892	994
D	165	191	210	273	330	356	419	508	559	603	686
V	200	250	250	300*	500*	600*	600*	900*	1000*	1000*	1000*
H	350	515	545	600	686	780	840	1235	1311	1430	1660
H1	370	535	570	630	726	830	910	1315	1411	1550	1800

(*) Se recomienda reductor manual

FIG. 463Y - GLOBO 'Y' WCB/F6 900LBS RF H. EXT.

DN	2"	2.1/2"	3"	4"	5"	6"	8"	10"	12"
L (RF/BW)	368	419	381	457	559	610	737	838	965
L (RTJ)	371	422	384	460	562	613	740	842	968
D	216	244	241	292	349	381	470	546	610
V	250	250	350*	500*	650*	700*	900*	1000*	1000*
H	575	690	590	720	870	973	1140	1500	1680
H1	605	730	634	780	928	1045	1230	1615	1810

(*) Se recomienda reductor manual

FIG. 464Y - GLOBO 'Y' WCB/F6 1500LBS RF H. EXT.

DN	2"	2.1/2"	3"	4"	5"	6"	8"	10"	12"
L (RF/BW)	368	419	381	457	559	610	737	838	965
L (RTJ)	371	422	384	460	562	613	740	842	968
D	216	244	241	292	349	381	470	546	610
V	250	250	350*	500*	650*	700*	900*	1000*	1000*
H	575	690	590	720	870	973	1140	1500	1680
H1	605	730	634	780	928	1045	1230	1615	1810

(*) Se recomienda reductor manual

ANSI EJECUCIONES ESPECIALES

GLOBO ANGULAR 150/1500LBS

GLOBO Acero carbono Fig. 46xA		Tipo: Asiento 90°
VÁLVULA GLOBO ANGULAR 150/1500LBS RF		
Materiales		
Cuerpo	Acero carbono	
Asiento	Acero inoxidable	
Obturador	Acero inoxidable	
Husillo	Acero inoxidable	
Empaquetadura	Grafito	
Junta cuerpo-tapa	Acero inox. / Grafito o RTJ	
Normas		
Diseño	BS 1873, ASME B16.34. Espesor de pared API 600	
Inspección y Pruebas	API 598, API 6D y BS 6755	
Distancia entre caras	ASME B16.10	

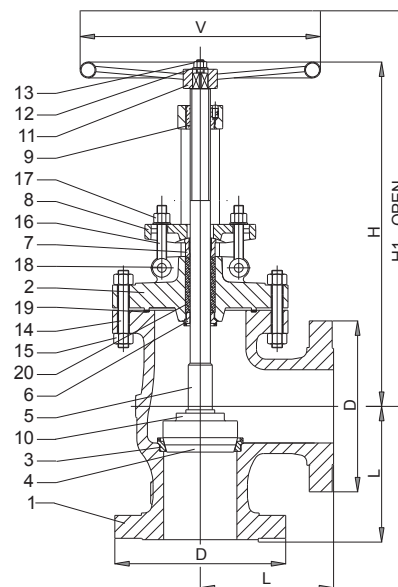

Pos.	Denominación	Componentes									
		Materiales estándar (*)									
1	Cuerpo	WCB	LCB	WC6	C5	C12	CF8	C8FC	CF8M	CF3M	
2	Tapa	WCB	LCB	WC6	C5	C12	CF8	CF8C	CF8M	CF3M	
3	Superficie asientos	F6a	F6a	F6a	F6a	F6a	F304	F321	F316	F316L	
4	Superficie obturador	F6a	F6a	F6a	F6a	F6a	F304	F321	F316	F316L	
5	Husillo	F6a	F6a	F6a	F6a	F6a	F304	F321	F316	F316L	
6	Cierre trasero	F6a	F6a	F6a	F6a	F6a	F304	F321	F316	F316	
7	Prensaestopas	F6a	F6a	F6a	F6a	F6a	F304	F321	F316	F316	
8	Brida prensaestopas	A105	F316	F316	F316	F316	F316	F316	F316	F316	
9	Tuerca guía husillo	B148 9A	B148 9A	F. Nodular	F. Nodular	F. Nodular	B148 9A	B148 9A	B148 9A	B148 9A	
10	Tuerca puente	F6a	F6a	F6a	F6a	F6a	F304	F321	F316	F316L	
11	Volante	Acero									
12	Placa	A105									
13	Tuerca volante	A105									
14	Tornillos	B7	L7	B16	B16	B16	B8	B8	B8	B8	
15	Tuercas	2H	G4	G4	G4	G4	G8	G8	G8	G8	
16	Tornillos de ojo	B7	B7	B8	B8	B8	B8	B8	B8	B8	
17	Tuercas	2H	2H	2H	2H	2H	G8	G8	G8	G8	
18	Pasador tornillo ojo	B7	B7	B7	B7	B7	B8	B8	B8	B8	
19	Junta	Acero inox. / Grafito o RTJ									
20	Empaquetadura	Grafito									

(*) Otros materiales bajo demanda

FIG. 460A - GLOBO ANGULAR WCB/F6 150LBS RF H. EXT.

DN	2"	2.1/2"	3"	4"	5"	6"	8"	10"	12"	14"	16"
L (RF/BW)	102	108	121	146	178	203	248	311	349	394	457
L (RTJ)	114	121	133	159	191	216	260	324	362	406	470
D	152	178	191	229	254	279	343	406	483	533	597
V	200	200	225	250	300	300	400*	500*	500*	800*	800*
H	384	420	456	516	576	672	816	900	1032	1092	1488
H1	399	440	480	546	614	717	876	975	1122	1197	1608

(*) Se recomienda reductor manual

FIG. 461A - GLOBO ANGULAR WCB/F6 300LBS RF H. EXT.

DN	2"	2.1/2"	3"	4"	5"	6"	8"	10"	12"	14"	16"
L (RF/BW)	133	146	159	178	200	222	279	311	356	(416)	(432)
L (RTJ)	149	162	174	194	216	238	287	327	371	(427)	(440)
D	165	191	210	254	279	318	381	445	521	584	648
V	200	225	225	300	300	400*	500*	600*	800*	1000*	1000*
H	468	480	492	528	684	816	960	1020	1212	1380	1656
H1	483	500	516	558	722	861	1020	1095	1302	1485	1776

(*) Se recomienda reductor manual

FIG. 462A - GLOBO ANGULAR WCB/F6 600LBS RF H. EXT.

DN	2"	2.1/2"	3"	4"	5"	6"	8"	10"	12"	14"	16"
L (RF/BW)	146	165	178	216	254	279	330	394	419	(444)	(496)
L (RTJ)	149	168	181	219	257	282	333	397	422	(496)	(497)
D	165	191	210	273	330	356	419	508	559	603	686
V	200	250	250	300*	500*	600*	600*	900*	1000*	1000*	1000*
H	420	618	654	720	823	936	1008	1482	1573	1716	2004
H1	435	638	678	750	861	981	1068	1557	1663	1821	2124

(*) Se recomienda reductor manual

FIG. 463A - GLOBO ANGULAR WCB/F6 900LBS RF H. EXT.

DN	2"	2.1/2"	3"	4"	5"	6"	8"	10"	12"
L (RF/BW)	184	210	191	229	279	305	368	419	483
L (RTJ)	187	213	194	232	282	308	371	422	486
D	216	244	241	292	349	381	470	546	610
V	250	250	350*	500*	650*	700*	900*	1000*	1000*
H	690	628	708	864	1044	1168	1368	1800	2016
H1	705	848	732	894	1082	1213	1428	1875	2106

(*) Se recomienda reductor manual

FIG. 464A - GLOBO ANGULAR WCB/F6 1500LBS RF H. EXT.

DN	2"	2.1/2"	3"	4"	5"	6"	8"	10"	12"
L (RF/BW)	216	254	305	406	483	559	711	864	991
L (RTJ)	219	257	308	409	486	565	721	873	1006
D	216	244	267	311	375	394	483	584	673
V	250*	250*	400*	500*	700*	900*	1000*	1000*	1000*
H	690	828	924	1008	1082	1168	1252	2004	2100
H1	705	848	948	1038	1120	1213	1312	2079	2190

(*) Se recomienda reductor manual

ANSI EJECUCIONES ESPECIALES

GLOBO CRIOGÉNICA ACERO INOX 150/1500LBS

GLOBO Acero inoxidable Fig. 46xEB		Tipo: Criogénica
VÁLVULA GLOBO CRIOGÉNICA 150/1500LBS RF		
Materiales		
Cuerpo	Acero inoxidable	
Asiento	Acero inoxidable	
Obturador	Acero inoxidable	
Husillo	Acero inoxidable	
Empaquetadura	PTFE	
Junta cuerpo-tapa	PTFE	
Normas		
Diseño	BS 1873, ASME B16.34. Espesor de pared API 600	
Inspección y Pruebas	API 598, API 6D y BS 6755	
Distancia entre caras	ASME B16.10	

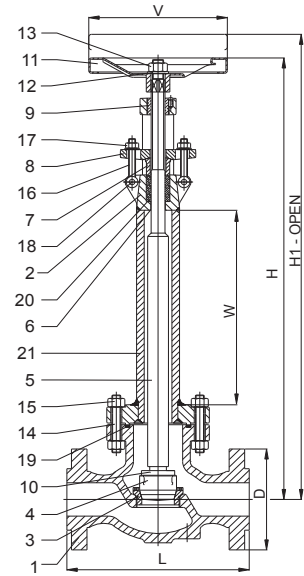

Componentes			
Pos.	Denominación	Materiales estándar (*)	
1	Cuerpo	CF8	CF8M
2	Tapa	CF8	CF8M
3	Superficie asientos	F316	F316
4	Superficie obturador	F316	F316
5	Husillo	F316	F316
6	Cierre trasero	CF8	CF8M
7	Prensaestopas	F316	F316
8	Brida prensaestopas	F316	F316
9	Tuerca guía husillo	B148 9A	B148 9A
10	Tuerca obturador	F316	F316
11	Volante	Acero	Acero
12	Placa	A105	A105
13	Tuerca volante	A105	A105
14	Tornillos	B8	B8
15	Tuercas	G8	G8
16	Tornillos ojo	B8	B8
17	Tuercas	G8	G8
18	Pasador tornillo ojo	B8	B8
19	Junta cuerpo-tapa	PTFE	PTFE
20	Empaquetadura	PTFE	PTFE
21	Extensión	F316L	F316L

(*) Otros materiales bajo demanda

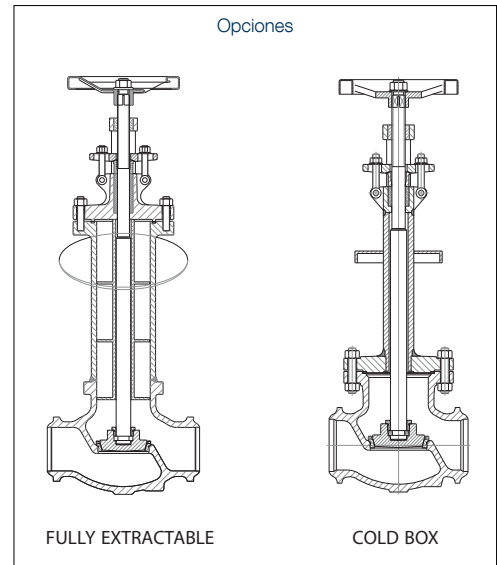

FIG. 460EB - GLOBO CRIOGÉNICA 150LBS RF H. EXT.

DN	2"	2.1/2"	3"	4"	5"	6"	8"	10"	12"	14"	16"
L (RF/BW)	203	216	241	292	356	406	495	622	699	787	914
L (RTJ)	216	219	254	305	368	419	508	635	711	800	927
D	152	178	191	229	254	279	343	406	483	533	597
V	200	200	225	250	300	300	400*	500*	500*	800*	800*
W	200	200	300	300	300	300	300	300	300	300	300
H	520	550	680	740	780	860	980	1050	1160	1240	1320
H1	535	570	704	770	818	905	1040	1125	1250	1360	1490

(*) Se recomienda reductor manual

FIG. 461EB - GLOBO CRIOGÉNICA 300LBS RF H. EXT.

DN	2"	2.1/2"	3"	4"	5"	6"	8"	10"	12"	14"	16"
L (RF/BW)	267	292	318	356	400	445	559	622	711	838	864
L (RTJ)	282	308	333	371	416	460	575	638	727	854	879
D	165	191	210	254	279	318	381	445	521	584	648
V	200	225	225	300	300	400*	500*	600*	800*	1000*	1000*
W	200	200	300	300	300	300	300	300	300	300	300
H	590	600	710	730	870	980	1100	1150	1310	1450	1530
H1	605	620	734	760	908	1025	1160	1225	1400	1555	1660

(*) Se recomienda reductor manual

FIG. 462EB - GLOBO CRIOGÉNICA 600LBS RF H. EXT.

DN	2"	2.1/2"	3"	4"	5"	6"	8"	10"	12"	14"	16"
L (RF/BW)	292	330	356	432	508	559	660	787	838	889	991
L (RTJ)	295	333	359	435	511	562	663	790	841	892	994
D	165	191	210	273	330	356	419	508	559	603	686
V	200	250	250	300*	500*	600*	600*	900*	1000*	1000*	1000*
W	200	200	300	300	300	300	300	300	300	300	300
H	550	715	845	900	986	1080	1140	1535	1611	1700	1820
H1	565	735	869	930	1024	1125	1200	1610	1701	1800	1930

(*) Se recomienda reductor manual

FIG. 463EB - GLOBO CRIOGÉNICA 900LBS RF H. EXT.

DN	2"	2.1/2"	3"	4"	5"	6"	8"	10"	12"
L (RF/BW)	368	419	381	457	559	610	737	838	965
L (RTJ)	371	422	384	460	562	613	740	842	968
D	216	244	241	292	349	381	470	546	610
V	250	250	350*	500*	650*	700*	900*	1000*	1000*
W	200	200	300	300	300	300	300	300	300
H	775	890	890	1020	1170	1273	1440	1800	1980
H1	790	910	914	1050	1208	1318	1500	1875	2070

(*) Se recomienda reductor manual

FIG. 464EB - GLOBO CRIOGÉNICA 1500LBS RF H. EXT.

DN	2"	2.1/2"	3"	4"	5"	6"	8"	10"	12"
L (RF/BW)	368	419	470	546	673	705	832	991	1130
L (RTJ)	371	422	473	549	676	711	842	1000	1146
D	216	244	267	311	375	394	483	584	673
V	250*	250*	400*	500*	700*	900*	1000*	1000*	1000*
W	200	200	300	300	300	300	300	300	300
H	775	890	1070	1140	1202	1273	1343	1970	2050
H1	790	910	1094	1170	1240	1318	1403	2045	2160

(*) Se recomienda reductor manual

ANSI EJECUCIONES ESPECIALES

GLOBO CON FUELLE 150/1500LBS

GLOBO Tipo Fuelle Fig. 46xSO		Tipo: Fuelle
VÁLVULA GLOBO CON FUELLE 150/1500LBS RF		
Materiales		
Cuerpo	Acero carbono	
Asiento	Acero inoxidable	
Obturador	Acero inoxidable	
Husillo	Acero inoxidable	
Empaquetadura	Grafito	
Junta cuerpo-tapa	Acero inox. / Grafito o RTJ	
Normas		
Diseño	BS 1873, ASME B16.34. Espesor de pared API 600	
Inspección y Pruebas	API 598, API 6D y BS 6755	
Distancia entre caras	ASME B16.10	

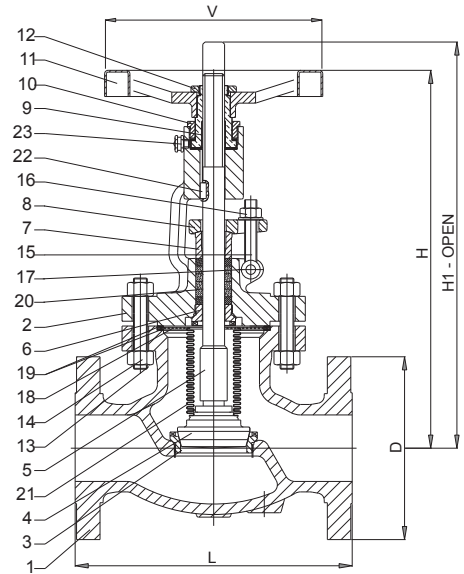

Pos.	Denominación	Componentes									
		Materiales estándar (*)									
1	Cuerpo	WCB	LCB	WC6	C5	C12	CF8	C8FC	CF8M	CF3M	
2	Tapa	WCB	LCB	WC6	C5	C12	CF8	CF8C	CF8M	CF3M	
3	Superficie asientos	F6a	F6a	F6a	F6a	F6a	F304	F321	F316	F316L	
4	Superficie obturador	F6a	F6a	F6a	F6a	F6a	F304	F321	F316	F316L	
5	Husillo	F6a	F6a	F6a	F6a	F6a	F304	F321	F316	F316L	
6	Cierre trasero	F6a	F6a	F6a	F6a	F6a	F304	F321	F316	F316	
7	Prensaestopas	F6a	F6a	F6a	F6a	F6a	F304	F321	F316	F316	
8	Brida prensaestopas	A105	F316	F316	F316	F316	F316	F316	F316	F316	
9	Tuerca guía husillo	B148 9A	B148 9A	F. Nodular	F. Nodular	F. Nodular	B148 9A	B148 9A	B148 9A	B148 9A	
10	Tuerca puente	F6a	F6a	F6a	F6a	F6a	F304	F321	F316	F316L	
11	Volante	Acero									
12	Tuerca volante	A105									
13	Tornillos	B7	L7	B16	B16	B16	B8	B8	B8	B8	
14	Tuercas	2H	G4	G4	G4	G4	G8	G8	G8	G8	
15	Tornillos de ojo	B7	B7	B8	B8	B8	B8	B8	B8	B8	
16	Tuercas	2H	2H	2H	2H	2H	G8	G8	G8	G8	
17	Pasador tornillo ojo	B7	B7	B7	B7	B7	B8	B8	B8	B8	
18	Brida fuelle	Acero inox. A182 F321									
19	Junta	Acero inox. / Grafito o RTJ									
20	Empaquetadura	Grafito									
21	Fuelle	Acero inox. A182 F321									
22	Dispositivo anti rotación	F6a	F6a	F6a	F6a	F6a	F304	F321	F316	F316L	
23	Nipple engrase	Acero									

(*) Otros materiales bajo demanda

FIG. 460SO - GLOBO CON FUELLE 150LBS RF H. EXT.

DN	2"	2.1/2"	3"	4"	5"	6"	8"	10"	12"	14"	16"
L (RF/BW)	203	216	241	292	356	406	495	622	699	787	914
L (RTJ)	216	219	254	305	368	419	508	635	711	800	927
D	152	178	191	229	254	279	343	406	483	533	597
V	200	200	225	250	300	300	400*	500*	500*	800*	800*
H	340	370	400	440	500	580	700	800	900	970	1270
H1	355	390	424	470	538	625	760	875	990	1090	1410

(*) Se recomienda reductor manual

FIG. 461SO - GLOBO CON FUELLE 300LBS RF H. EXT.

DN	2"	2.1/2"	3"	4"	5"	6"	8"	10"	12"	14"	16"
L (RF/BW)	267	292	318	356	400	445	559	622	711	838	864
L (RTJ)	282	308	333	371	416	460	575	638	727	854	879
D	165	191	210	254	279	318	381	445	521	584	648
V	200	225	225	300	300	400*	500*	600*	800*	1000*	1000*
H	410	420	430	480	590	700	820	900	1050	1200	1440
H1	425	440	454	504	628	745	880	975	1140	1320	1800

(*) Se recomienda reductor manual

FIG. 462SO - GLOBO CON FUELLE 600LBS RF H. EXT.

DN	2"	2.1/2"	3"	4"	5"	6"	8"	10"	12"	14"	16"
L (RF/BW)	292	330	356	432	508	559	660	787	838	889	991
L (RTJ)	295	333	359	435	511	562	663	790	841	892	994
D	165	191	210	273	330	356	419	508	559	603	686
V	200	250	250	300*	500*	600*	600*	900*	1000*	1000*	1000*
H	370	525	565	620	700	800	860	1280	1350	1490	1720
H1	385	545	589	650	738	845	920	1355	1440	1630	2100

(*) Se recomienda reductor manual

FIG. 463SO - GLOBO CON FUELLE 900LBS RF H. EXT.

DN	2"	2.1/2"	3"	4"	5"	6"	8"	10"	12"
L (RF/BW)	368	419	381	457	559	610	737	838	965
L (RTJ)	371	422	384	460	562	613	740	842	968
D	216	244	241	292	349	381	470	546	610
V	250	250	350*	500*	650*	700*	900*	1000*	1000*
H	590	710	610	750	890	1000	1170	1540	1720
H1	605	730	634	780	928	1045	1230	1615	1810

(*) Se recomienda reductor manual

FIG. 464SO - GLOBO CON FUELLE 1500LBS RF H. EXT.

DN	2"	2.1/2"	3"	4"	5"	6"	8"	10"	12"
L (RF/BW)	368	419	470	546	673	705	832	991	1130
L (RTJ)	371	422	473	549	676	711	842	1000	1146
D	216	244	267	311	375	394	483	584	673
V	250*	250*	400*	500*	700*	900*	1000*	1000*	1000*
H	590	710	790	860	930	1000	1100	1720	1810
H1	605	730	814	890	968	1045	1160	1795	1950

(*) Se recomienda reductor manual

ANSI EJECUCIONES ESPECIALES

GLOBO CON FUELLE 'Y' 150/1500LBS

GLOBO Tipo Fuelle 'Y' Fig. 46xYSO		Tipo: Fuelle 'Y'
VÁLVULA GLOBO CON FUELLE 'Y' 150/1500LBS RF		
Materiales		
Cuerpo	Acero carbono	
Asiento	Acero inoxidable	
Obturador	Acero inoxidable	
Husillo	Acero inoxidable	
Empaquetadura	Grafito	
Junta cuerpo-tapa	Acero inox. / Grafito o RTJ	
Normas		
Diseño	BS 1873, ASME B16.34. Espesor de pared API 600	
Inspección y Pruebas	API 598, API 6D y BS 6755	
Distancia entre caras	ASME B16.10	

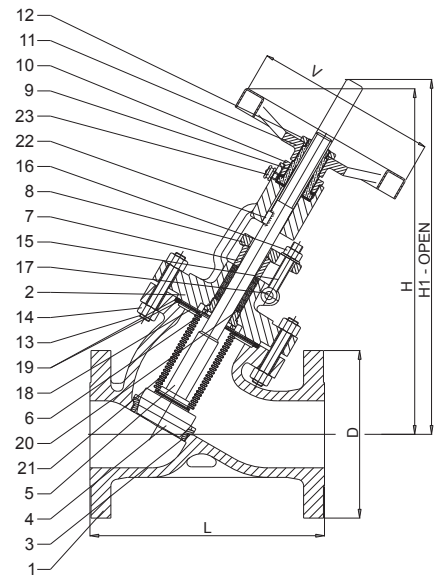

Pos.	Denominación	Componentes									
		Materiales estándar (*)									
1	Cuerpo	WCB	LCB	WC6	C5	C12	CF8	C8FC	CF8M	CF3M	
2	Tapa	WCB	LCB	WC6	C5	C12	CF8	CF8C	CF8M	CF3M	
3	Superficie asientos	F6a	F6a	F6a	F6a	F6a	F304	F321	F316	F316L	
4	Superficie obturador	F6a	F6a	F6a	F6a	F6a	F304	F321	F316	F316L	
5	Husillo	F6a	F6a	F6a	F6a	F6a	F304	F321	F316	F316L	
6	Cierre trasero	F6a	F6a	F6a	F6a	F6a	F304	F321	F316	F316	
7	Prensaestopas	F6a	F6a	F6a	F6a	F6a	F304	F321	F316	F316	
8	Brida prensaestopas	A105	F316	F316	F316	F316	F316	F316	F316	F316	
9	Tuerca guía husillo	B148 9A	B148 9A	F. Nodular	F. Nodular	F. Nodular	B148 9A	B148 9A	B148 9A	B148 9A	
10	Tuerca puente	F6a	F6a	F6a	F6a	F6a	F304	F321	F316	F316L	
11	Volante	Acero									
12	Tuerca volante	A105									
13	Tornillos	B7	L7	B16	B16	B16	B8	B8	B8	B8	
14	Tuercas	2H	G4	G4	G4	G4	G8	G8	G8	G8	
15	Tornillos de ojo	B7	B7	B8	B8	B8	B8	B8	B8	B8	
16	Tuercas	2H	2H	2H	2H	2H	G8	G8	G8	G8	
17	Pasador tornillo ojo	B7	B7	B7	B7	B7	B8	B8	B8	B8	
18	Brida fuelle	Acero inox. A182 F321									
19	Junta	Acero inox. / Grafito o RTJ									
20	Empaquetadura	Grafito									
21	Fuelle	Acero inox. A182 F321									
22	Dispositivo anti rotación	F6a	F6a	F6a	F6a	F6a	F304	F321	F316	F316L	
23	Nipple engrase	Acero									

(*) Otros materiales bajo demanda

FIG. 460YSO - GLOBO CON FUELLE 'Y' 150LBS RF H. EXT.

DN	2"	2.1/2"	3"	4"	5"	6"	8"	10"	12"	14"	16"
L (RF/BW)	203	216	241	292	356	406	495	622	699	787	914
L (RTJ)	216	219	254	305	368	419	508	635	711	800	927
D	152	178	191	229	254	279	343	406	483	533	597
V	200	200	225	250	300	300	400*	500*	500*	800*	800*
H	320	350	380	440	480	560	680	750	860	930	1250
H1	380	430	470	550	615	720	890	1010	1170	1040	1380

(*) Se recomienda reductor manual

FIG. 461YSO - GLOBO CON FUELLE 'Y' 300LBS RF H. EXT.

DN	2"	2.1/2"	3"	4"	5"	6"	8"	10"	12"	14"	16"
L (RF/BW)	267	292	318	356	400	445	559	622	711	838	864
L (RTJ)	282	308	333	371	416	460	575	638	727	854	879
D	165	191	210	254	279	318	381	445	521	584	648
V	200	225	225	300	300	400*	500*	600*	800*	1000*	1000*
H	390	400	410	430	570	680	800	850	1010	1150	1390
H1	410	420	435	520	615	735	860	930	1110	1270	1512

(*) Se recomienda reductor manual

FIG. 462YSO - GLOBO CON FUELLE 'Y' 600LBS RF H. EXT.

DN	2"	2.1/2"	3"	4"	5"	6"	8"	10"	12"	14"	16"
L (RF/BW)	292	330	356	432	508	559	660	787	838	889	991
L (RTJ)	295	333	359	435	511	562	663	790	841	892	994
D	165	191	210	273	330	356	419	508	559	603	686
V	200	250	250	300*	500*	600*	600*	900*	1000*	1000*	1000*
H	350	515	545	600	686	780	840	1235	1311	1430	1660
H1	370	535	570	630	726	830	910	1315	1411	1550	1800

(*) Se recomienda reductor manual

FIG. 463YSO - GLOBO CON FUELLE 'Y' 900LBS RF H. EXT.

DN	2"	2.1/2"	3"	4"	5"	6"	8"	10"	12"
L (RF/BW)	368	419	381	457	559	610	737	838	965
L (RTJ)	371	422	384	460	562	613	740	842	968
D	216	244	241	292	349	381	470	546	610
V	250	250	350*	500*	650*	700*	900*	1000*	1000*
H	575	690	590	720	870	973	1140	1500	1680
H1	605	730	634	780	928	1045	1230	1615	1810

(*) Se recomienda reductor manual

FIG. 464YSO - GLOBO CON FUELLE 'Y' 1500LBS RF H. EXT.

DN	2"	2.1/2"	3"	4"	5"	6"	8"	10"	12"
L (RF/BW)	368	419	470	546	673	705	832	991	1130
L (RTJ)	371	422	473	549	676	711	842	1000	1146
D	216	244	267	311	375	394	483	584	673
V	250*	250*	400*	500*	700*	900*	1000*	1000*	1000*
H	575	690	770	840	902	973	1043	1670	1750
H1	615	740	826	915	980	1080	1190	1760	1855

(*) Se recomienda reductor manual

ANSI EJECUCIONES ESPECIALES

GLOBO PRESSURE SEAL 600/2500LBS

GLOBO Pressure Seal Fig. P6x		Tipo: Pressure Seal
VÁLVULA GLOBO PRESSURE SEAL 600/2500LBS RF		
Materiales		
Cuerpo	Acero carbono	
Asiento	Acero inoxidable	
Obturador	Acero inoxidable	
Husillo	Acero inoxidable	
Empaquetadura	Grafito	
Junta cuerpo-tapa	Acero inox. / Grafito	
Normas		
Diseño	BS 1873 y ASME B16.34	
Inspección y Pruebas	API 598, API 6D y BS 6755	
Distancia entre caras	ASME B16.10	

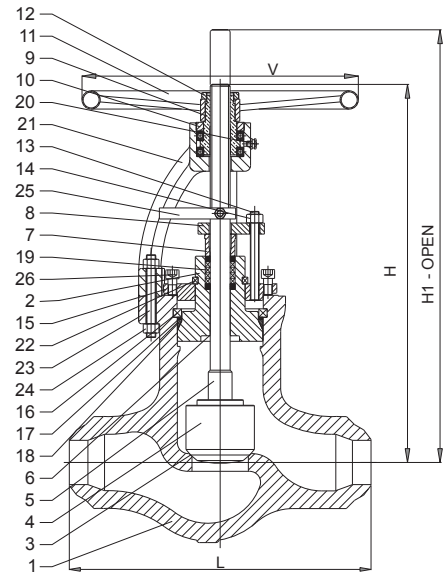

Pos.	Denominación	Componentes				
		Materiales estándar (*)				
1	Cuerpo	WCB	WC1	WC6	WC9	CF8M
2	Tapa	WCB	WC1	WC6	WC9	CF8M
3	Asiento (integral)			Stellite®		
4	Superficie obturador	WCB + HF	WC1 + HF	WC6 + HF	WC9 + HF	CF8M + HF
5	Husillo	F6a	F6a	F6a	F6a	F316
6	Cierre trasero (integral)			Stellite®		
7	Prensaestopas	F6a	F6a	F6a	F6a	F316
8	Brida prensaestopas	A105	F316	F316	F316	F316
9	Tuerca guía husillo			B148 9A		
10	Tuerca puente	A105	A105	A105	A105	F316
11	Volante			Acero		
12	Tuerca volante			A105		
13	Tornillos	B7	B16	B16	B16	B8
14	Tuercas	2H	G4	G4	G4	G8
15	Anillo retén	A105	F6a	F6a	F6a	F316
16	Anillo partido	F6a	F6a	F6a	F6a	F316
17	Anillo espaciador	F6a	F6a	F6a	F6a	F316
18	Junta			Acero inox. / Grafito		
19	Empaquetadura			Grafito		
20	Nipple engrasador			Acero		
21	Puente	WCB	WC1	WC6	WC9	CF8M
22	Anillo partido	F6a	F6a	F6a	F6a	F316
23	Tornillo puente / cuerpo	B7	B16	B16	B16	B8
24	Tuerca puente / cuerpo	2H	G4	G4	G4	G8
25	Dispositivo anti rotación	2H	G4	G4	G4	G8
26	Tornillos	B7	B16	B16	B16	B8

(*) Otros materiales bajo demanda

FIG. P62 - GLOBO PRESSURE SEAL 600LBS RF H. EXT.

DN	2"	3"	4"	6"	8"	10"	12"	14"	16"
L (RF)	292	356	432	559	660	787	838	889	991
L (RTJ)	295	359	435	562	663	790	841	892	994
L (BW)	292	356	432	559	660	787	838	889	991
V	200	250	300	Reductor	Reductor	Reductor	Reductor	Reductor	Reductor
H	500	550	590	840	970	1160	1300	1480	1680
H1	540	600	670	930	1120	1350	1525	1750	1980

FIG. P63 - GLOBO PRESSURE SEAL 900LBS RF H. EXT.

DN	2"	3"	4"	6"	8"	10"	12"	14"	16"
L (RF)	368	381	457	610	737	838	965	1029	1130
L (RTJ)	371	384	460	613	740	842	968	1038	1140
L (BW)	368	381	457	610	737	838	965	1029	1130
V	250	300	Reductor	Reductor	Reductor	Reductor	Reductor	Reductor	Reductor
H	500	550	590	840	970	1160	1300	1585	1639
H1	540	600	670	930	1120	1350	1525	1850	1940

FIG. P64 - GLOBO PRESSURE SEAL 1500LBS RF H. EXT.

DN	2"	3"	4"	6"	8"	10"	12"
L (RF)	368	470	546	705	832	991	1130
L (RTJ)	371	473	549	711	842	1000	1146
L (BW)	368	470	546	705	832	991	1130
V	250	Reductor	Reductor	Reductor	Reductor	Reductor	Reductor
H	500	550	590	840	970	1250	1400
H1	540	600	670	930	1120	1350	1525

FIG. P65 - GLOBO PRESSURE SEAL 2500LBS RF H. EXT.

DN	2"	3"	4"	6"	8"	10"	12"
L (RF)	451	578	673	914	1022	1270	1422
L (RTJ)	454	584	683	927	1038	1292	1445
L (BW)	451	578	673	914	1022	1270	1422
V	Reductor	Reductor	Reductor	Reductor	Reductor	Reductor	Reductor
H	500	550	600	860	1000	1330	1700
H1	540	600	680	950	1150	1430	1825

ANSI EJECUCIONES ESPECIALES

GLOBO PRESSURE SEAL 'Y' 600/2500LBS

GLOBO Pressure Seal 'Y' Fig. P8x		Tipo: Pressure Seal 'Y'
VÁLVULA GLOBO PRESSURE SEAL 'Y' 600/2500LBS RF		
Materiales		
Cuerpo	Acero carbono	
Asiento	Acero inoxidable	
Obturador	Acero inoxidable	
Husillo	Acero inoxidable	
Empaquetadura	Grafito	
Junta cuerpo-tapa	Acero inox. / Grafito	
Normas		
Diseño	BS 1873 y ASME B16.34	
Inspección y Pruebas	API 598, API 6D y BS 6755	
Distancia entre caras	ASME B16.10	

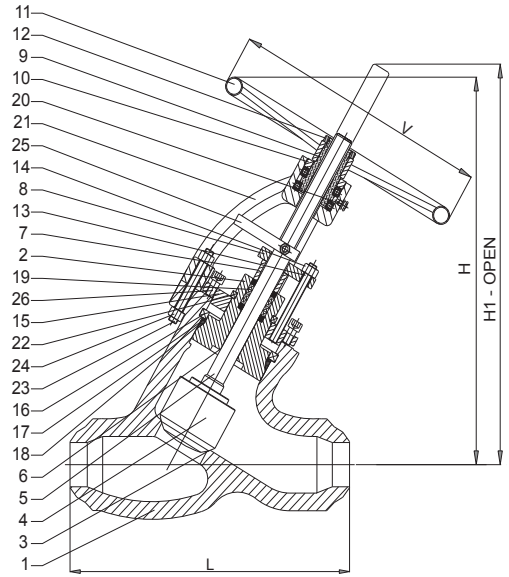

Pos.	Denominación	Componentes				
		Materiales estándar (*)				
1	Cuerpo	WCB	WC1	WC6	WC9	CF8M
2	Tapa	WCB	WC1	WC6	WC9	CF8M
3	Asiento (integral)	Stellite®				
4	Superficie obturador	WCB + HF	WC1 + HF	WC6 + HF	WC9 + HF	CF8M + HF
5	Husillo	F6a	F6a	F6a	F6a	F316
6	Cierre trasero (integral)	Stellite®				
7	Prensaestopas	F6a	F6a	F6a	F6a	F316
8	Brida prensaestopas	A105	F316	F316	F316	F316
9	Tuerca guía husillo	B148 9A				
10	Tuerca puente	A105	A105	A105	A105	F316
11	Volante	Acero				
12	Tuerca volante	A105				
13	Tornillos	B7	B16	B16	B16	B8
14	Tuercas	2H	G4	G4	G4	G8
15	Anillo retén	A105	F6a	F6a	F6a	F316
16	Anillo partido	F6a	F6a	F6a	F6a	F316
17	Anillo espaciador	F6a	F6a	F6a	F6a	F316
18	Junta	Acero inox. / Grafito				
19	Empaquetadura	Grafito				
20	Nipple engrasador	Acero				
21	Puente	WCB	WC1	WC6	WC9	CF8M
22	Anillo partido	F6a	F6a	F6a	F6a	F316
23	Tornillo puente / cuerpo	B7	B16	B16	B16	B8
24	Tuerca puente / cuerpo	2H	G4	G4	G4	G8
25	Dispositivo anti rotación	2H	G4	G4	G4	G8
26	Tornillos	B7	B16	B16	B16	B8

(*) Otros materiales bajo demanda

FIG. P82 - GLOBO PRESSURE SEAL 'Y' 600LBS RF H. EXT.

DN	2"	3"	4"	6"	8"	10"	12"	14"	16"
L (RF)	292	356	432	559	660	787	838	889	991
L (RTJ)	295	359	435	562	663	790	841	892	994
L (BW)	292	356	432	559	660	787	838	889	991
V	200	250	300	Reductor	Reductor	Reductor	Reductor	Reductor	Reductor
H	500	550	590	840	970	1160	1300	1480	1680
H1	540	600	670	930	1120	1270	1425	1620	1840

FIG. P83 - GLOBO PRESSURE SEAL 'Y' 900LBS RF H. EXT.

DN	2"	3"	4"	6"	8"	10"	12"	14"	16"
L (RF)	368	381	457	610	737	838	965	1029	1130
L (RTJ)	371	384	460	613	740	842	968	1038	1140
L (BW)	368	381	457	610	737	838	965	1029	1130
V	250	300	Reductor	Reductor	Reductor	Reductor	Reductor	Reductor	Reductor
H	500	550	640	900	960	1080	1200	1380	1585
H1	540	600	715	995	1110	1380	1425	1643	1885

FIG. P84 - GLOBO PRESSURE SEAL 'Y' 1500LBS RF H. EXT.

DN	2"	3"	4"	6"	8"	10"	12"
L (RF)	368	470	546	705	832	991	1130
L (RTJ)	371	473	549	711	842	1000	1146
L (BW)	368	470	546	705	832	991	1130
V	250	Reductor	Reductor	Reductor	Reductor	Reductor	Reductor
H	520	550	640	900	1165	1210	1575
H1	560	600	715	995	1315	1400	1800

FIG. P85 - GLOBO PRESSURE SEAL 'Y' 2500LBS RF H. EXT.

DN	2"	3"	4"	6"	8"	10"	12"
L (RF)	451	578	673	914	1022	1270	1422
L (RTJ)	454	584	683	927	1038	1292	1445
L (BW)	451	578	673	914	1022	1270	1422
V	Reductor	Reductor	Reductor	Reductor	Reductor	Reductor	Reductor
H	550	550	670	1145	1235	1435	1610
H1	590	600	750	1240	1385	1625	1835

ANSI EJECUCIONES ESPECIALES

RETENCIÓN PISTÓN 150/1500LBS

RETENCIÓN Pistón Fig. 46xPC		Tipo: Pistón con Muelle
VÁLVULA RETENCIÓN PISTÓN 150/1500LBS RF		
Materiales		
Cuerpo	Acero carbono	
Asiento	Acero inoxidable	
Obturador	Acero inoxidable	
Muelle	Acero inoxidable	
Junta cuerpo-tapa	Acero inox. / Grafito o RTJ	
Normas		
Diseño	BS 1873, API 600 y ASME B16.34	
Inspección y Pruebas	API 598, API 6D y BS 6755	
Distancia entre caras	ASME B16.10	

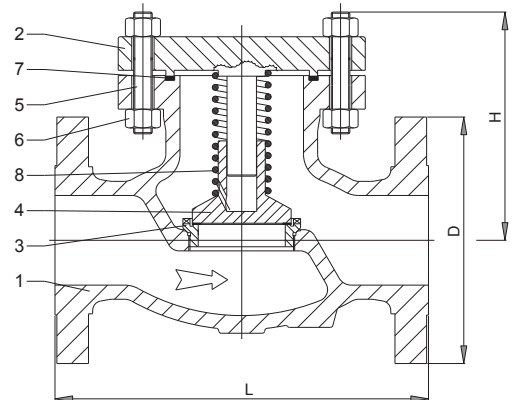

Componentes		Materiales estándar (*)								
Pos.	Denominación									
1	Cuerpo	WCB	LCB	WC6	C5	C12	CF8	C8FC	CF8M	CF3M
2	Tapa	WCB	LCB	WC6	C5	C12	CF8	CF8C	CF8M	CF3M
3	Superficie asientos	F6a	F6a	F6a	F6a	F6a	F304	F321	F316	F316L
4	Superficie obturador	F6a	F6a	F6a	F6a	F6a	F304	F321	F316	F316L
5	Muelle	F316								
6	Tornillos	B7	L7	B16	B16	B16	B8	B8	B8	B8
7	Tuercas	2H	G4	G4	G4	G4	G8	G8	G8	G8
8	Junta cuerpo-tapa	Acero inox. / Grafito o RTJ								

(*) Otros materiales bajo demanda

FIG. 460PC - RETENCIÓN PISTÓN 150LBS RF

DN	2"	2.1/2"	3"	4"	5"	6"	8"	10"	12"	14"	16"
L (RF/BW)	203	216	241	292	356	406	495	622	699	787	914
L (RTJ)	216	219	254	305	368	419	508	635	711	800	927
D	152	178	191	229	254	279	343	406	483	533	597
H	155	180	185	195	215	250	295	330	380	420	500

FIG. 461PC - RETENCIÓN PISTÓN 300LBS RF

DN	2"	2.1/2"	3"	4"	5"	6"	8"	10"	12"	14"	16"
L (RF/BW)	267	292	318	356	400	445	559	622	711	838	864
L (RTJ)	282	308	333	371	416	460	575	638	727	854	879
D	165	191	210	254	279	318	381	445	521	584	648
H	155	180	185	195	215	250	295	330	380	420	500

FIG. 462PC - RETENCIÓN PISTÓN 600LBS RF

DN	2"	2.1/2"	3"	4"	5"	6"	8"	10"	12"
L (RF/BW)	292	330	356	432	508	559	660	787	838
L (RTJ)	295	333	359	435	511	562	663	790	841
D	165	191	210	273	330	356	419	508	559
H	155	180	195	220	306	320	380	480	505

FIG. 463PC - RETENCIÓN PISTÓN 900LBS RF

DN	2"	2.1/2"	3"	4"	5"	6"	8"	10"	12"
L (RF/BW)	368	419	381	457	559	610	737	838	965
L (RTJ)	371	422	384	460	562	613	740	842	968
D	216	244	241	292	349	381	470	546	610
H	220	230	240	280	330	365	409	536	600

FIG. 464PC - RETENCIÓN PISTÓN 1500LBS RF

DN	2"	2.1/2"	3"	4"	5"	6"	8"	10"	12"
L (RF/BW)	368	419	470	546	673	705	832	991	1130
L (RTJ)	371	422	473	549	676	711	842	1000	1146
D	216	244	267	311	375	394	483	584	673
H	220	230	280	325	400	430	716	762	818

ANSI EJECUCIONES ESPECIALES

RETENCIÓN PISTÓN 'Y' 150/2500LBS

RETENCIÓN Pistón 'Y' Fig. 49xPC		Tipo: Pistón 'Y'
VÁLVULA RETENCIÓN PISTÓN 'Y' 150/2500LBS RF		
Materiales		
Cuerpo	Acero carbono	
Asiento	Acero inoxidable	
Obturador	Acero inoxidable	
Muelle	Acero inoxidable	
Junta cuerpo-tapa	Acero inox. / Grafito o RTJ	
Normas		
Diseño	BS 1873, API 600 y ASME B16.34	
Inspección y Pruebas	API 598, API 6D y BS 6755	
Distancia entre caras	ASME B16.10	

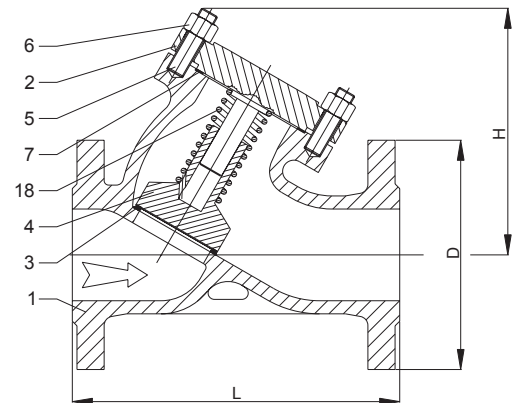

Componentes		Materiales estándar (*)								
Pos.	Denominación	WCB	LCB	WC6	C5	C12	CF8	C8FC	CF8M	CF3M
1	Cuerpo	WCB	LCB	WC6	C5	C12	CF8	C8FC	CF8M	CF3M
2	Tapa	WCB	LCB	WC6	C5	C12	CF8	CF8C	CF8M	CF3M
3	Superficie asientos	F6a	F6a	F6a	F6a	F6a	F304	F321	F316	F316L
4	Superficie obturador	F6a	F6a	F6a	F6a	F6a	F304	F321	F316	F316L
5	Muelle	F316								
6	Tornillos	B7	L7	B16	B16	B16	B8	B8	B8	B8
7	Tuercas	2H	G4	G4	G4	G4	G8	G8	G8	G8
8	Junta cuerpo-tapa	Acero inox. / Grafito o RTJ								

(*) Otros materiales bajo demanda

FIG. 490PC - RETENCIÓN PISTÓN 'Y' 150LBS RF

DN	2"	2.1/2"	3"	4"	5"	6"	8"	10"	12"	14"	16"	18"	20"	24"
L (RF/BW)	203	216	241	292	356	406	495	622	699	787	914	978	978	1295
L (RTJ)	216	219	254	305	368	419	508	635	711	800	927	991	991	1308
D	152	178	191	229	254	279	343	406	483	533	597	635	699	813
H	146	185	195	235	301	366	530	530	665	-	-	-	-	-

FIG. 491PC - RETENCIÓN PISTÓN 'Y' 300LBS RF

DN	2"	2.1/2"	3"	4"	5"	6"	8"	10"	12"	14"	16"	18"	20"	24"
L (RF/BW)	267	292	318	356	400	445	559	622	711	838	864	978	1016	1346
L (RTJ)	282	308	333	371	416	460	575	638	727	854	879	994	1035	1368
D	165	191	210	254	279	318	381	445	521	584	648	711	775	914
H	145	190	223	235	300	330	365	570	740	-	-	-	-	-

FIG. 492PC - RETENCIÓN PISTÓN 'Y' 600LBS RF

DN	2"	2.1/2"	3"	4"	5"	6"	8"	10"	12"	14"	16"	18"	20"	24"
L (RF/BW)	292	330	356	432	508	559	660	787	838	889	991	1092	1194	1397
L (RTJ)	295	333	359	435	511	562	663	790	841	892	994	1095	1200	1407
D	165	191	210	273	330	356	419	508	559	603	686	743	813	940
H	185	210	230	290	370	425	470	-	-	-	-	-	-	-

FIG. 493PC - RETENCIÓN PISTÓN 'Y' 900LBS RF

DN	2"	3"	4"	6"	8"	10"	12"	14"	16"
L (RF/BW)	368	381	457	610	737	838	965	1029	1130
L (RTJ)	371	384	460	613	740	842	968	1038	1140
D	216	241	292	381	470	546	610	641	705
H	-	-	-	-	-	-	-	-	-

FIG. 494PC - RETENCIÓN PISTÓN 'Y' 1500LBS RF

DN	2"	3"	4"	6"	8"	10"	12"	14"	16"
L (RF/BW)	368	470	546	705	832	991	1130	1257	1384
L (RTJ)	371	473	549	711	842	1000	1146	1276	1407
D	216	267	311	394	483	584	673	749	826
H	-	-	-	-	-	-	-	-	-

FIG. 495PC - RETENCIÓN PISTÓN 'Y' 2500LBS RF

DN	2"	3"	4"	6"	8"	10"	12"
L (RF/BW)	451	578	673	914	1022	1270	1422
L (RTJ)	454	584	683	927	1038	1292	1445
D	235	305	356	483	552	673	762
H	-	-	-	-	-	-	-

ANSI EJECUCIONES ESPECIALES

RETENCIÓN CLAPETA PRESSURE SEAL 600/2500LBS

RETENCIÓN Clapeta Pressure Seal Fig. P7x		Tipo: Pressure Seal
VÁLVULA RETENCIÓN CLAPETA PRESSURE SEAL 600/2500LBS RF		
Materiales		
Cuerpo	Acero carbono	
Asiento	Acero inoxidable	
Obturador	Acero inoxidable	
Junta cuerpo-tapa	Acero inox. / Grafito	
Normas		
Diseño	BS 1868 y API 6D	
Inspección y Pruebas	API 598, API 6D y BS 6755	
Distancia entre caras	ASME B16.10	

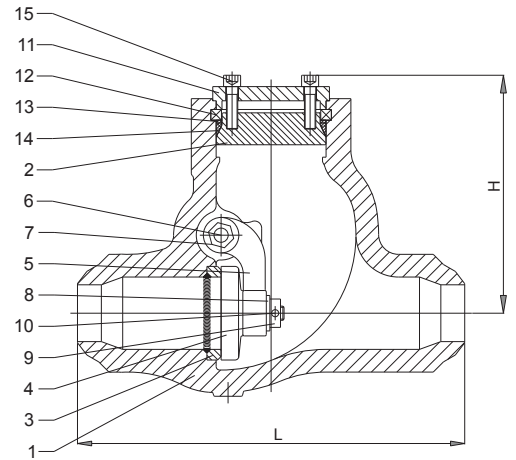

Pos.	Denominación	Componentes				
		Materiales estándar (*)				
1	Cuerpo	WCB	WC1	WC6	WC9	CF8M
2	Tapa	WCB	WC1	WC6	WC9	CF8M
3	Asiento (integral)	Stellite®				
4	Asiento obturador	A105 + HF	F6a + HF	F6a + HF	F6a + HF	F316 + HF
5	Biela	WCB	WC1	WC6	WC9	CF8M
6	Pasador biela	F6a	F6a	F6a	F6a	F316
7	Tapón (externamente)	A105	F316	F316	F316	F316
8	Arandela	A105	F316	F316	F316	F316
9	Tuerca	2H	G4	G4	G4	G8
10	Pasador	F316	F316	F316	F316	F316
11	Anillo retén	A105	F6a	F6a	F6a	F316
12	Anillo partido	F6a	F6a	F6a	F6a	F316
13	Anillo espaciador	F6a	F6a	F6a	F6a	F316
14	Junta cuerpo-tapa	Acero inox. / Grafito				
15	Tornillo	B7	B16	B16	B16	B8

(*) Otros materiales bajo demanda

FIG. P72 - RETENCIÓN CLAPETA PRESSURE SEAL 600LBS RF

DN	2"	3"	4"	6"	8"	10"	12"	14"	16"	18"	20"	24"
L (RF/BW)	292	356	432	559	660	787	838	889	991	1092	1194	1397
L (RTJ)	295	359	435	562	663	790	841	892	994	1095	1200	1407
H	180	215	275	350	390	450	500	555	630	710	800	1000

FIG. P73 - RETENCIÓN CLAPETA PRESSURE SEAL 900LBS RF

DN	2"	3"	4"	6"	8"	10"	12"	14"	16"	18"	20"	24"
L (RF/BW)	368	381	457	610	737	838	965	1029	1130	1219	1321	1549
L (RTJ)	371	384	460	613	740	842	968	1038	1140	1232	1334	1568
H	245	250	310	390	510	580	620	680	740	800	850	1100

FIG. P74 - RETENCIÓN CLAPETA PRESSURE SEAL 1500LBS RF

DN	2"	3"	4"	6"	8"	10"	12"	14"	16"	18"	20"	24"
L (RF/BW)	368	470	546	705	832	991	1130	1257	1384	1537	1664	1943
L (RTJ)	371	473	549	711	842	1000	1146	1276	1407	1559	1686	1972
H	245	290	350	420	630	690	750	800	980	1100	1300	1550

FIG. P75 - RETENCIÓN CLAPETA PRESSURE SEAL 2500LBS RF

DN	2"	3"	4"	6"	8"	10"	12"
L (RF/BW)	451	578	673	914	1022	1270	1422
L (RTJ)	454	584	683	927	1038	1292	1445
H	245	300	380	430	650	720	780

RETENCIÓN PISTÓN PRESSURE SEAL 600/2500LBS

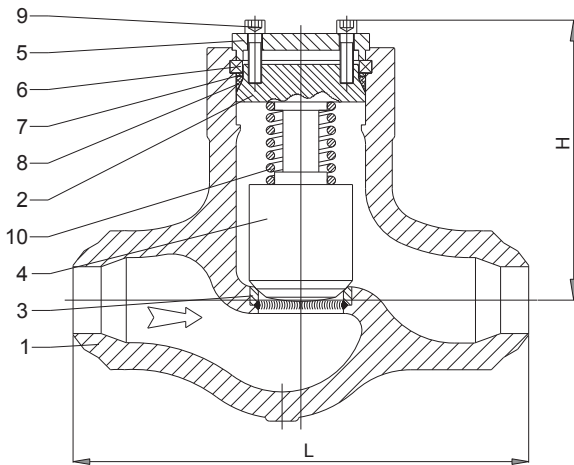

RETENCIÓN Pistón Pressure Seal Fig. P6xPC		Tipo: Pressure Seal
VÁLVULA RETENCIÓN PISTÓN PRESSURE SEAL 600/2500LBS RF		
Materiales		
Cuerpo	Acero carbono	
Asiento	Acero inoxidable	
Muelle	Acero inoxidable	
Junta cuerpo-tapa	Acero inox. / Grafito	
Normas		
Diseño	BS 1873 y API 6D	
Inspección y Pruebas	API 598, API 6D y BS 6755	
Distancia entre caras	ASME B16.10	

Pos.	Denominación	Componentes				
		Materiales estándar				
1	Cuerpo	WCB	WC1	WC6	WC9	CF8M
2	Tapa	WCB	WC1	WC6	WC9	CF8M
3	Asiento (integral)	Stellite®				
4	Asiento obturador	A105 + HF	F6a + HF	F6a + HF	F6a + HF	F316 + HF
5	Anillo retén	A105	F6a	F6a	F6a	F316
6	Anillo partido	F6a	F6a	F6a	F6a	F316
7	Anillo espaciador	F6a	F6a	F6a	F6a	F316
8	Junta cuerpo-tapa	Acero inox. / Grafito				
9	Tornillo	B7	B16	B16	B16	B8
10	Muelle	F316				

(*) Otros materiales bajo demanda

FIG. P62PC - RETENCIÓN PISTÓN PRESSURE SEAL 600LBS RF

DN	2"	3"	4"	6"	8"	10"	12"	14"	16"
L (RF/BW)	292	356	432	559	660	787	838	889	991
L (RTJ)	295	359	435	562	663	790	841	892	994
H	230	280	330	450	520	600	700	800	900

FIG. P63PC - RETENCIÓN PISTÓN PRESSURE SEAL 900LBS RF

DN	2"	3"	4"	6"	8"	10"	12"	14"	16"
L (RF/BW)	368	381	457	610	737	838	965	1029	1130
L (RTJ)	371	384	460	613	740	842	968	1038	1140
H	270	300	390	430	520	600	700	800	900

FIG. P64PC - RETENCIÓN PISTÓN PRESSURE SEAL 1500LBS RF

DN	2"	3"	4"	6"	8"	10"	12"
L (RF/BW)	368	470	546	705	832	991	1130
L (RTJ)	371	473	549	711	842	1000	1146
H	270	310	400	440	530	620	720

FIG. P65PC - RETENCIÓN PISTÓN PRESSURE SEAL 2500LBS RF

DN	2"	3"	4"	6"	8"	10"	12"
L (RF/BW)	451	578	673	914	1022	1270	1422
L (RTJ)	454	584	683	927	1038	1292	1445
H	270	310	400	440	530	620	720

ANSI EJECUCIONES ESPECIALES

RETENCIÓN PISTÓN PRESSURE SEAL 'Y' 600/2500LBS

RETENCIÓN Pistón Pressure Seal 'Y' Fig. P8xPC		Tipo: Pressure Seal
VÁLVULA RETENCIÓN PISTÓN PRESSURE SEAL 'Y' 600/2500LBS RF		
Materiales		
Cuerpo	Acero carbono	
Asiento	Acero inoxidable	
Muelle	Acero inoxidable	
Junta cuerpo-tapa	Acero inox. / Grafito	
Normas		
Diseño	BS 1873 y API 6D	
Inspección y Pruebas	API 598, API 6D y BS 6755	
Distancia entre caras	ASME B16.10	

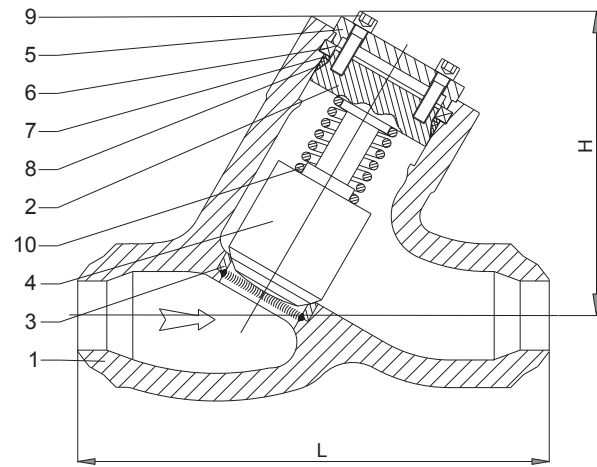

Pos.	Denominación	Componentes				
		Materiales estándar (*)				
1	Cuerpo	WCB	WC1	WC6	WC9	CF8M
2	Tapa	WCB	WC1	WC6	WC9	CF8M
3	Asiento (integral)	Stellite®				
4	Asiento obturador	A105 + HF	F6a + HF	F6a + HF	F6a + HF	F316 + HF
5	Anillo retén	A105	F6a	F6a	F6a	F316
6	Anillo partido	F6a	F6a	F6a	F6a	F316
7	Anillo espaciador	F6a	F6a	F6a	F6a	F316
8	Junta cuerpo-tapa	Acero inox. / Grafito				
9	Tornillo	B7	B16	B16	B16	B8
10	Muelle	F316				

(*) Otros materiales bajo demanda

FIG. P82PC - RETENCIÓN PISTÓN PRESSURE SEAL 'Y' 600LBS RF

DN	2"	3"	4"	6"	8"	10"	12"	14"	16"
L (RF/BW)	292	356	432	559	660	787	838	889	991
L (RTJ)	295	359	435	562	663	790	841	892	994
H	253	308	363	495	572	660	770	880	990

FIG. P83PC - RETENCIÓN PISTÓN PRESSURE SEAL 'Y' 900LBS RF

DN	2"	3"	4"	6"	8"	10"	12"	14"	16"
L (RF/BW)	368	381	457	610	737	838	965	1029	1130
L (RTJ)	371	384	460	613	740	842	968	1038	1140
H	297	330	429	473	572	660	770	880	990

FIG. P84PC - RETENCIÓN PISTÓN PRESSURE SEAL 'Y' 1500LBS RF

DN	2"	3"	4"	6"	8"	10"	12"
L (RF/BW)	368	470	546	705	832	991	1130
L (RTJ)	371	473	549	711	842	1000	1146
H	297	341	440	484	583	682	792

FIG. P85PC - RETENCIÓN PISTÓN PRESSURE SEAL 'Y' 2500LBS RF

DN	2"	3"	4"	6"	8"	10"	12"
L (RF/BW)	451	578	673	914	1022	1270	1422
L (RTJ)	454	584	683	927	1038	1292	1445
H	297	341	440	484	583	682	792

RETENCIÓN TILTING DISC 600/2500LBS

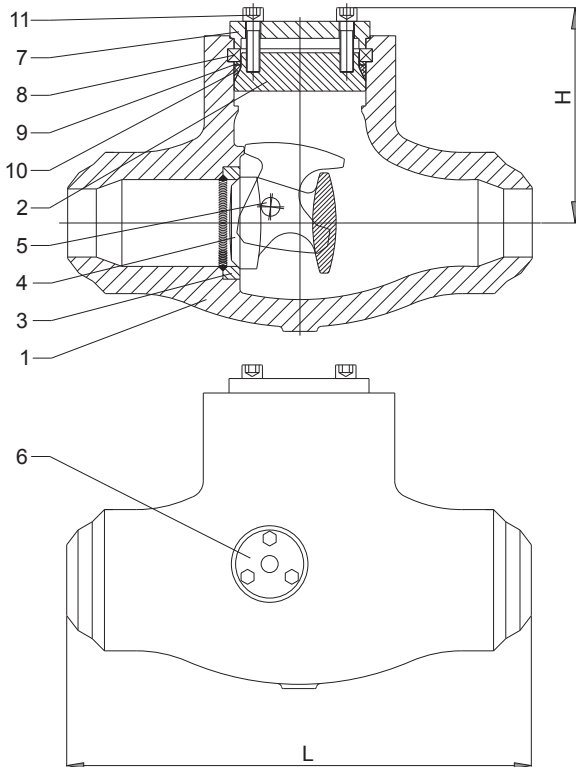

RETENCIÓN Tilting Disc Fig. P7xT		Tipo: Tilting Disc
VÁLVULA RETENCIÓN TILTING DISC 600/2500LBS RF		
Materiales		
Cuerpo	Acero carbono	
Asiento	Acero inoxidable	
Junta cuerpo-tapa	Acero inox. / Grafito	
Normas		
Diseño	BS 1873 y API 6D	
Inspección y Pruebas	API 598, API 6D y BS 6755	
Distancia entre caras	ASME B16.10	

Pos.	Denominación	Componentes				
		Materiales estándar (*)				
1	Cuerpo	WCB	WC1	WC6	WC9	CF8M
2	Tapa	WCB	WC1	WC6	WC9	CF8M
3	Asiento (integral)	Stellite®				
4	Asiento obturador	A105 + HF	F6a + HF	F6a + HF	F6a + HF	F316 + HF
5	Pasador	F6a	F6a	F6a	F6a	F316
6	Tapón (externamente)	A105	F6a	F6a	F6a	F316
7	Anillo retén	A105	F316	F316	F316	F316
8	Anillo partido	F6a	F6a	F6a	F6a	F316
9	Anillo espaciador	F6a	F6a	F6a	F6a	F316
10	Junta cuerpo-tapa	F316				
11	Tornillo	B7	B16	B16	B16	B8

(*) Otros materiales bajo demanda

FIG. P72T - RETENCIÓN TILTING DISC 600LBS RF

DN	2"	3"	4"	6"	8"	10"	12"	14"	16"	18"	20"	24"
L (RF)	292	356	432	559	660	787	838	889	991	1092	1194	1397
L (RTJ)	295	359	435	562	663	790	841	892	994	1095	1200	1407
L (BW)	178	254	305	457	584	711	813	889	991	1092	1194	1397
H	180	215	275	350	390	450	500	555	630	710	800	1000

FIG. P73T - RETENCIÓN TILTING DISC 900LBS RF

DN	2"	3"	4"	6"	8"	10"	12"	14"	16"	18"	20"	24"
L (RF)	368	381	457	610	737	838	965	1029	1130	1219	1321	1549
L (RTJ)	371	384	460	613	740	842	968	1038	1140	1232	1334	1568
L (BW)	216	305	356	508	660	787	914	991	1092	1143	1245	1397
H	245	250	310	390	510	580	620	680	740	800	850	1100

FIG. P74T - RETENCIÓN TILTING DISC 1500LBS RF

DN	2"	3"	4"	6"	8"	10"	12"	14"	16"	18"	20"	24"
L (RF)	368	470	546	705	832	991	1130	1257	1384	1537	1664	1943
L (RTJ)	371	473	549	711	842	1000	1146	1276	1407	1559	1686	1972
L (BW)	216	305	406	559	711	864	991	1067	1194	1346	1473	1943
H	245	290	350	420	630	690	750	800	980	1100	1300	1550

FIG. P75T - RETENCIÓN TILTING DISC 2500LBS RF

DN	2"	3"	4"	6"	8"	10"	12"
L (RF)	451	578	673	914	1022	1270	1422
L (RTJ)	454	584	683	927	1038	1292	1445
L (BW)	279	368	457	610	762	914	1041
H	245	300	380	430	650	720	780

ALQUILACIÓN

En la química orgánica, se denomina alquilación a la transferencia de un grupo alquilo de una molécula a otra. El grupo alquilo puede ser transferido como un carbocatión de alquilo, un radical libre, un carbanión o un carbeno (o sus equivalentes). Los agentes alquilantes son ampliamente utilizados en la química ya que el grupo alquilo es probablemente el grupo más común entre las moléculas orgánicas. Numerosas moléculas orgánicas objetivo o sus precursores sintéticos están formadas por una cadena alquilo que contiene grupos funcionales específicos en un determinado orden. Se utiliza la alquilación selectiva, o el agregado de partes a la cadena con los grupos funcionales deseados, especialmente cuando no existe un precursor biológico común. La alquilación con solo un átomo de carbono se denomina metilación.

En el contexto de la refinación del petróleo, se utiliza el término alquilación para referirse a un procedimiento en donde se combinan olefinas con parafinas para formar isoparafinas de alto nivel. Es usual la alquilación del isobutileno (olefina) con isobutano para producir una mezcla del isobutano con isooctano. Es un proceso muy importante en la refinación del petróleo porque produce un número de octanos superior a 87.





PACIFIC VALVES

VÁLVULAS PARA ALQUILACIÓN



INTRODUCCIÓN

Experiencia

PACIFIC es especialista en la fabricación de válvulas para alquiler durante más de 50 años. PACIFIC es considerado pionero en el desarrollo de este tipo de válvula. De hecho, es el único fabricante originalmente homologado por los más grandes licenciatarios para uso con ácido fluorhídrico (U.O.P., Phillips Petroleum y Chevron) para todo el rango de medidas y presiones.

Los elementos en Monel® llevan un código de color para su correcta identificación. Pero antes incluso de montar la pieza de Monel® en una válvula para Alquiler es sometida a un ensayo ácido para asegurar que efectivamente es de la calidad requerida para el proceso. Otro aspecto importante en la fabricación de este tipo de válvulas es el espacio entre las partes críticas de metal en contacto (cuña/guías del cuerpo, husillo/casquillo del cierre trasero, etc.). El ácido fluorhídrico reacciona con el acero carbono y el Monel® produciendo una acumulación de fluoruro en las superficies metálicas, provocando que la válvula deje de ser operativa. Estos espacios, desarrollados durante años gracias a la experiencia en la fabricación, la investigación y pruebas, deben ser controlados con precisión para evitar estas acumulaciones.

Calidad certificada

Todos los ensayos de presión y de los materiales son supervisadas por un inspector que certifica su precisión. Cada una de las válvulas salen al mercado con su certificación individual.

Cada una de las válvulas es probada

El 100% de las válvulas son probadas con queroseno para ácido fluorhídrico. La experiencia ha demostrado que el queroseno es el mejor fluido de prueba ideal por las siguientes razones:

- » Previene el agua atrapada; el agua atrapada en los internos de la válvula acelera la corrosión.
- » Asegura la calidad de la fundición; el queroseno es menos viscoso que el agua. De esta manera se puede localizar más rápidamente un defecto en la fundición que si se prueba con otros fluidos.
- » Proporciona fiabilidad en el ensayo del asiento; de nuevo, la viscosidad del queroseno supone un indicador más fiable frente a fugas en los asientos.

Las válvulas para ácido fluorhídrico son probadas durante un largo periodo de tiempo con el fin de comprobar su funcionamiento. Además, son probadas con helio a 300 p.s.i. para asegurarse de la integridad de la fundición.

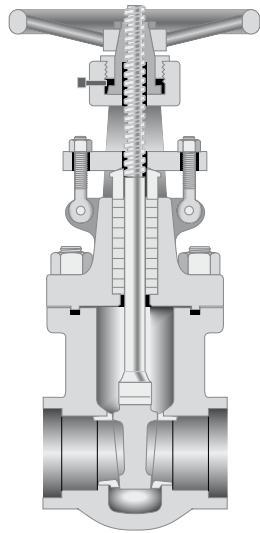

Válvula de Compuerta API 602

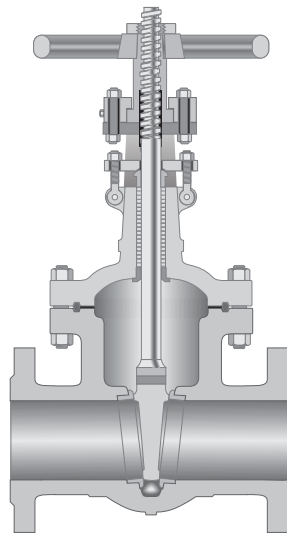

Válvula de Compuerta API 600

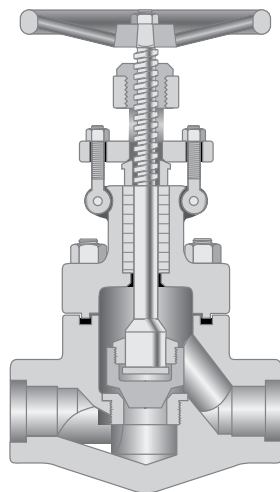

Válvula de Globo API 602

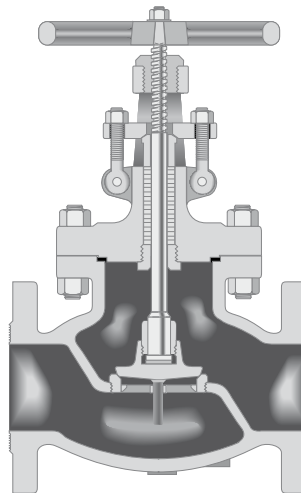

Válvula de Globo API 600

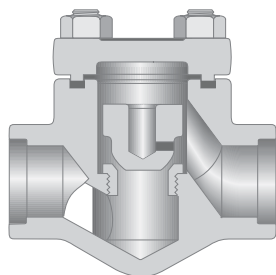

Válvula de Retención a Clapeta API 602

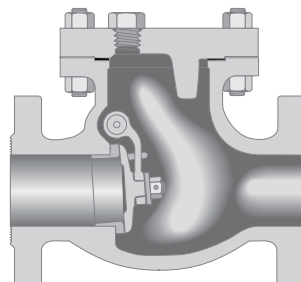

Válvula de Retención a Clapeta API 600

VÁLVULAS PARA ALQUILACIÓN

COMPUERTA ALQUILACIÓN 800LBS UOP 1/2" - 2"

CRANE® PACIFIC Compuerta Fig. 3656-HF8		Diseño: API 602
VÁLVULA COMPUERTA PARA SERVICIOS DE ALQUILACIÓN		
Especificaciones		
Material cuerpo	Acero carbono (Fundido o Forjado)	
Asientos	Monel®	
Conexiones	Bridas, Roscadas o Socket Weld	
Rating	800LBS	
Pruebas	API 598 y API 622 "Packing Emission" para válvulas de proceso	
Fire Safe	Según API 607 (última edición)	
Presión prueba	Cuerpo: 3000 psig Asiento: 2200 psig Cuerpo (helio): 500 psig	
Aplicaciones	Fundamentalmente en la industria Petroquímica	

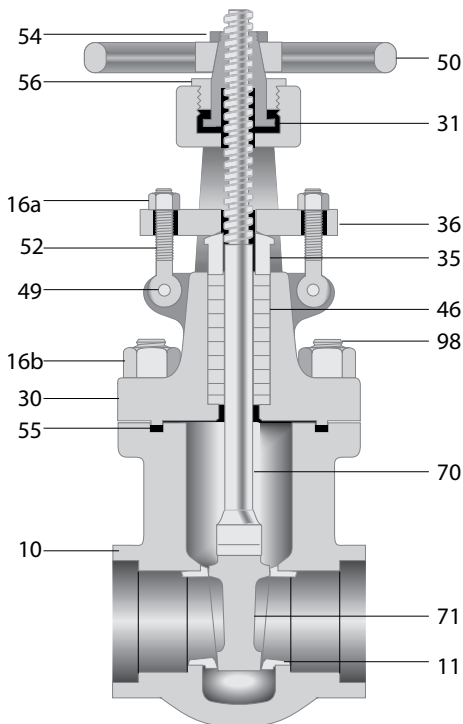
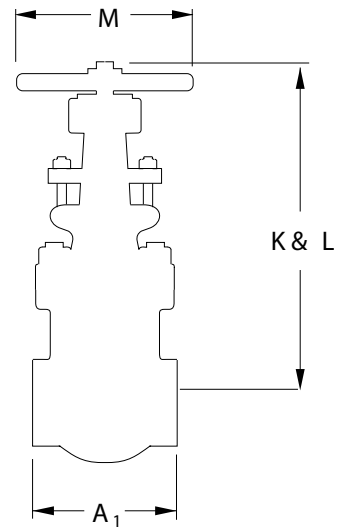

Pos.	Denominación	Componentes	
		Denominación	Material
10	Cuerpo	ASTM A216 WCB o ASTM A105	
11	Asiento	Monel®	
16a	Tuerca	ASTM A194 2H	
16b	Tuerca	ASTM A194 2HM	
30	Tapa	ASTM A216 WCB o ASTM A105	
31	Tuerca guía husillo	12% Cromo	
35	Prensaestopas	Monel®	
36	Brida prensaestopas	Acero carbono	
46	Empaquetadura	Grafito	
49	Pasador	Acero carbono	
50	Volante	Hierro maleable	
52	Tornillo de ojo	Acero carbono	
54	Tuerca volante	Acero carbono	
55	Junta cuerpo-tapa	Espirometálica Monel®/Grafito	
56	Contratuerca	Acero carbono	
59	Accesorio engrasador	Acero carbono	
70	Husillo	K-Monel®	
71	Cuña	Monel®	
98	Espárrago	ASTM A193 B7M	

FIG. 3656-HF8 - COMPUERTA ALQUILACIÓN 800LBS SW UOP

DIM.	DESCRIPCIÓN	TAMAÑO VÁLVULA				
		1/2"	3/4"	1"	1.1/2"	2"
A ₁	Distancia entre caras SW	89	89	105	121	133
K	Abierta	259	259	282	402	402
L	Cerrada	236	236	252	347	347
M	Diám. volante	108	108	108	140	203
X	Profundidad paso SW	13	13	13	13	16
Y	Diámetro paso SW	27	27	34	49	61
	Peso (kg.)	4,1	4,1	6,4	10,9	17,7

COMPUERTA ALQUILACIÓN 800LBS UOP 1/2" - 2"

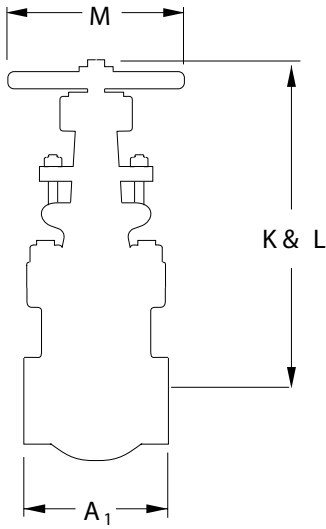

CRANE® PACIFIC Compuerta Fig. 3656-HF8 (-M35-1)		Diseño: API 602
VÁLVULA COMPUERTA PARA SERVICIOS DE ALQUILACIÓN		
Especificaciones		
Material cuerpo	ASTM A494 Gr. M35-1	
Asientos	Monel®	
Conexiones	Bridas, Roscadas o Socket Weld	
Rating	800LBS	
Pruebas	API 598 y API 622 "Packing Emission" para válvulas de proceso	
Fire Safe	Según API 607 (última edición)	
Presión prueba	Cuerpo: 3000 psig Asiento: 2200 psig Cuerpo (helio): 500 psig	
Aplicaciones	Fundamentalmente en la industria Petroquímica	

Componentes		
Pos.	Denominación	Material
10	Cuerpo	Monel según ASTM A494 Gr. M-35-1
11	Asiento	Monel®
16a	Tuerca	ASTM A194 2H
16b	Tuerca	ASTM A194 2HM
30	Tapa	ASTM A216 WCB o ASTM A105
31	Tuerca guía husillo	12% Cromo
35	Prensaestopas	Monel®
36	Brida prensaestopas	Acero carbono
46	Empaquetadura	Grafito
49	Pasador	Acero carbono
50	Volante	Hierro maleable
52	Tornillo de ojo	Acero carbono
54	Tuerca volante	Acero carbono
55	Junta cuerpo-tapa	Espirometálica Monel®/Grafito
56	Contratuerca	Acero carbono
59	Accesorio engrasador	Acero carbono
70	Husillo	K-Monel®
71	Cuña	Monel®
98	Espárrago	ASTM A193 B7M

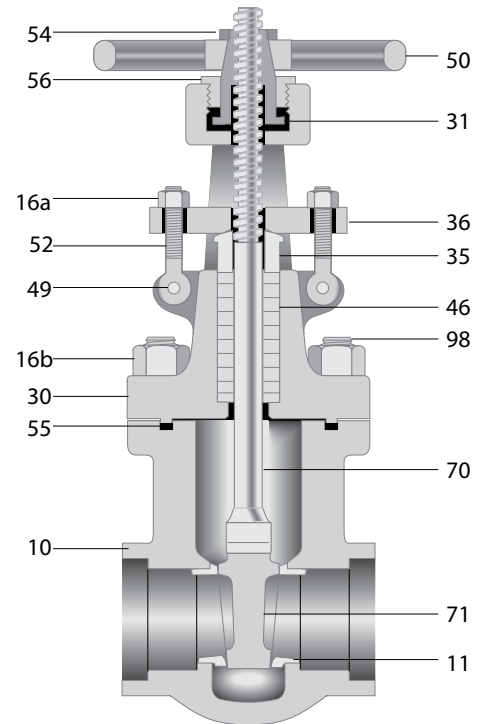

FIG. 3656-HF8 (-M35-1) - COMPUERTA ALQUILACIÓN 800LBS SW UOP

DIM.	DESCRIPCIÓN	TAMAÑO VÁLVULA				
		1/2"	3/4"	1"	1.1/2"	2"
A ₁	Distancia entre caras SW	76	89	105	121	133
K	Abierta	221	259	282	402	402
L	Cerrada	203	236	252	347	347
M	Diám. volante	102	108	108	140	203
X	Profundidad paso SW	10	13	13	13	16
Y	Diámetro paso SW	22	27	34	49	61
	Peso (kg.)	3,2	4,1	6,4	10,9	17,7

VÁLVULAS PARA ALQUILACIÓN

COMPUERTA ALQUILACIÓN 300LBS UOP 1.1/2" - 8"

CRANE® PACIFIC Compuerta Fig. 357GR-HF8 (-M35-1)		Diseño: API 602
VÁLVULA COMPUERTA PARA SERVICIOS DE ALQUILACIÓN		
Especificaciones		
Material cuerpo	ASTM A494 Gr. M35-1	
Asientos	Monel®	
Conexiones	Bridas, Roscadas o Socket Weld	
Rating	300LBS	
Pruebas	API 598 y API 622 "Packing Emission" para válvulas de proceso	
Fire Safe	Según API 607 (última edición)	
Presión prueba	Cuerpo: 1125 psig Asiento: 825 psig Cuerpo (helio): 500 psig	
Aplicaciones	Fundamentalmente en la industria Petroquímica	

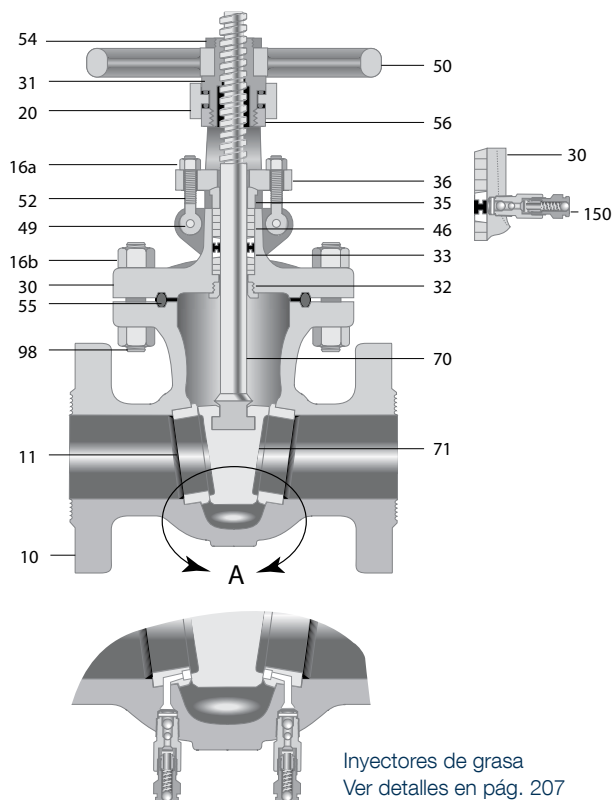
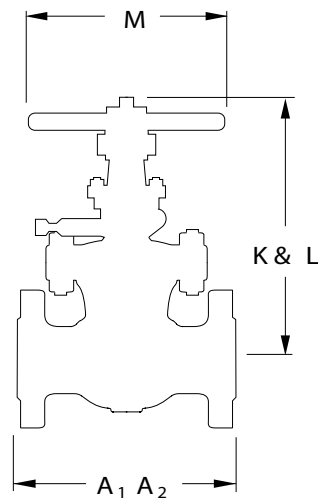

Componentes		
Pos.	Denominación	Material
10	Cuerpo	ASTM A494 Gr. M35-1
11	Asientos	Monel® con inserto de PTFE
16b	Tuerca	ASTM A194 Gr. 2HM
16a	Tuerca	ASTM A194 Gr. 2H
20	Cojinetes	Acero aleado
30	Tapa	ASTM A494 Gr. M35-1
31	Tuerca guía husillo	Bronce-Aluminio
32	Casquillo husillo	Monel®
33	Linterna	Monel®
35	Prensaestopas	Monel®
36	Brida prensaestopas	Acero carbono
46	Empaquetadura	Grafito
49	Pasador	Acero carbono
50	Volante	Hierro maleable
52	Tornillo de ojo	Acero carbono
54	Tuerca volante	Acero carbono
55	Junta tapa	Anillo Monel®
56	Contratuerca	Acero carbono
70	Husillo	Monel®
71	Cuña	Monel®
98	Espárrago	ASTM A193 Gr. B7M
150	Inyector grasa	Acero carbono y Monel®

FIG. 357GR-HF8 (-M35-1) - COMPUERTA ALQUILACIÓN 300LBS RF UOP

DIM.	DESCRIPCIÓN	TAMAÑO VÁLVULA							
		1.1/2"	2"	2.1/2"	3"	4"	6"	8"	
A ₁	Distancia entre caras RF	191	216	241	283	305	403	419	
A ₂	Distancia entre caras RTJ	203	232	257	299	321	419	435	
K	Abierta	546	552	662	662	875	1084	1292	
L	Cerrada	495	502	584	584	762	921	1079	
M	Diám. volante	254	254	254	254	356	457	610	
	Peso (kg.)	30	32	57	61	98	175	297	

COMPUERTA ALQUILACIÓN 600LBS UOP 1/2" - 2"

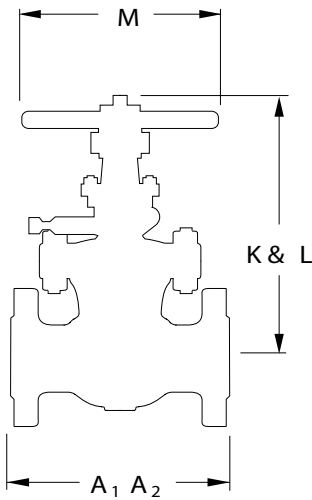

CRANE® PACIFIC Compuerta Fig. 3654GR-HF8 (-M35-1)		Diseño: API 900
VÁLVULA COMPUERTA PARA SERVICIOS DE ALQUILACIÓN		
Especificaciones		
Material cuerpo	ASTM A494 Gr. M35-1	
Asientos	Monel® 400	
Conexiones	Bridas, Roscadas o Socket Weld	
Rating	600LBS	
Pruebas	API 598 y API 622 "Packing Emission" para válvulas de proceso	
Fire Safe	Según API 607 (última edición)	
Presión prueba	Cuerpo: 2250 psig Asiento: 1650 psig Cuerpo (helio): 500 psig	
Aplicaciones	Fundamentalmente en la industria Petroquímica	

Componentes		
Pos.	Denominación	Material
10	Cuerpo	Monel según ASTM A494 Gr. M-35-1
11	Asiento	Monel® 400
16a	Tuerca	Acero carbono
16b	Tuerca	ASTM A194 2HM
30	Tapa	ASTM A494 Gr. M35-1
31	Tuerca guía husillo	12% Cromo
35	Prensaestopas	Monel® 400
36	Brida prensaestopas	Acero carbono
46	Empaquetadura	Grafito
49	Pasador	Acero carbono
50	Volante	Hierro maleable
52	Tornillo de ojo	Acero carbono
54	Tuerca volante	Acero carbono
55	Junta cuerpo-tapa	Junta RTJ Monel®
56	Contratuerca	Acero carbono
59	Accesorio engrasador	Acero carbono
70	Husillo	K-Monel®
71	Cuña	Monel® 400
98	Espárrago	ASTM A193 B7M
150	Inyector grasa	Acero carbono y Monel®

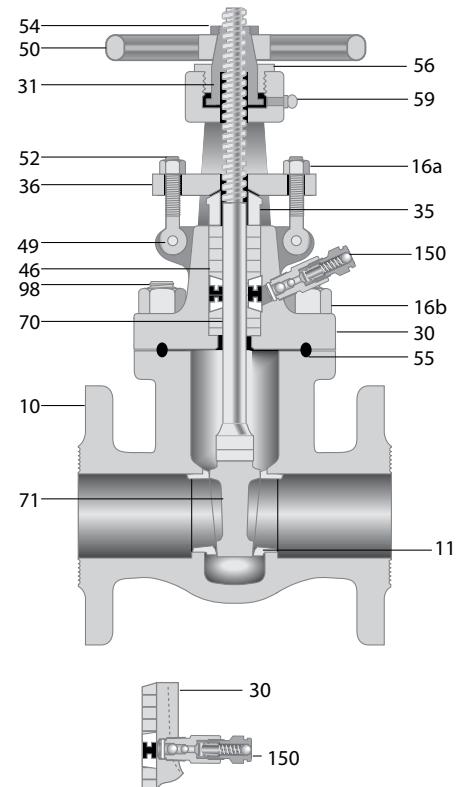

FIG. 3654GR-HF8 (-M35-1) - COMPUERTA ALQUILACIÓN 600LBS BRIDAS UOP

DIM.	DESCRIPCIÓN	TAMAÑO VÁLVULA				
		1/2"	3/4"	1"	1.1/2"	2"
A ₁	Distancia entre caras	165	191	216	241	292
K	Abierta	241	261	286	378	402
L	Cerrada	219	234	256	330	347
M	Diám. volante	102	114	114	140	203
	Peso (kg.)	5,0	7,3	10,0	18,2	27,3

VÁLVULAS PARA ALQUILACIÓN

COMPUERTA ALQUILACIÓN 800LBS UOP 1.1/2" - 2"

CRANE® PACIFIC Compuerta Fig. 3656G-HF8T		Diseño: API 602
VÁLVULA COMPUERTA PARA SERVICIOS DE ALQUILACIÓN		
Especificaciones		
Material cuerpo	ASTM A216 Gr. WCB o ASTM A105	
Asientos	Monel® con inserto de PTFE	
Conexiones	Bridas, Roscadas o Socket Weld	
Rating	800LBS	
Pruebas	API 598 y API 622 "Packing Emission" para válvulas de proceso	
Fire Safe	Según API 607 (última edición)	
Presión prueba	Cuerpo: 3000 psig Asiento: 2200 psig Cuerpo (helio): 500 psig	
Aplicaciones	Fundamentalmente en la industria Petroquímica	

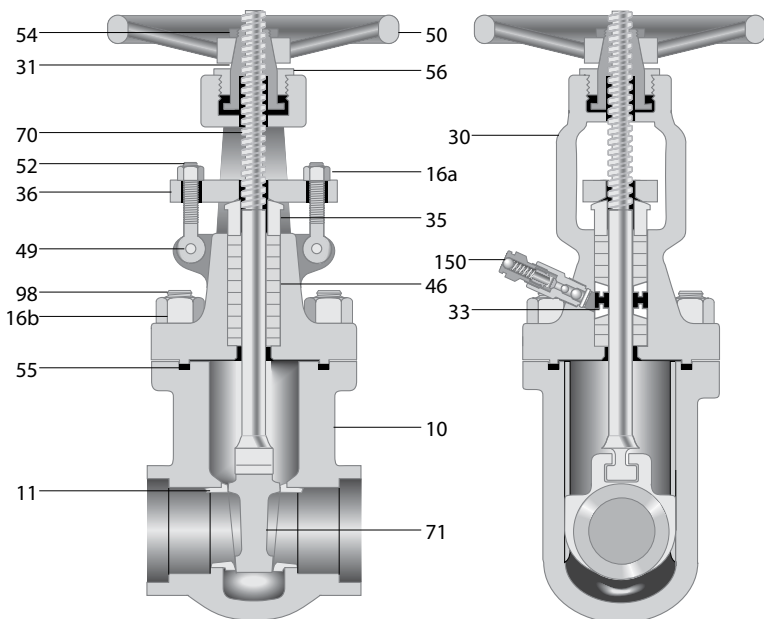
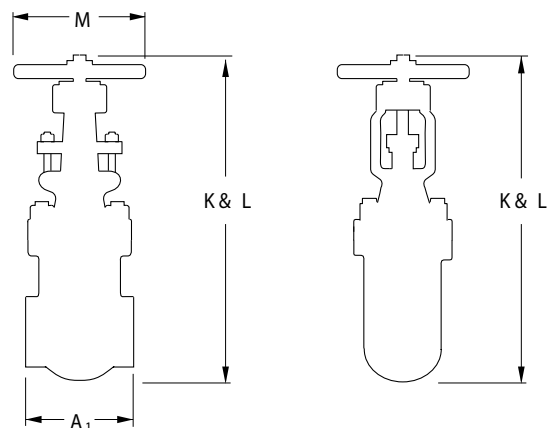

Componentes			
Pos.	Denominación	Material	
70	Husillo	K-Monel®	
54	Tuerca volante	Acero carbono	
50	Volante	Hierro maleable	
31	Tuerca guía husillo	12% Cromo	
56	Contratuerca	Acero carbono	
150	Accesorio engrasador	Acero carbono	
30	Tapa	ASTMA A216 Gr. WCB o ASTM A105	
150	Inyector grasa	Acero carbono y Monel®	
52	Tornillo de ojo	Acero carbono	
16a	Tuerca	Acero carbono	
36	Brida prensaestopas	Acero carbono	
35	Prensaestopas	Monel®	
49	Pasador	Acero carbono	
98	Espárrago	ASTM A193 Gr. B7M	
16b	Tuerca	ASTM A194 Gr. 2HM	
33	Linterna	Monel®	
46	Empaquetadura	Grafito	
55	Junta cuerpo-tapa	Espirometálica Monel® / Grafito	
10	Cuerpo	ASTM A216 Gr. WCB o ASTM A105	
11	Asientos	Monel® con inserto de PTFE	
71	Cuña	Monel®	

FIG. 3576G-HF8T - COMPUERTA ALQUILACIÓN 800LBS SW UOP

DIM.	DESCRIPCIÓN	TAMAÑO VÁLVULA				
		1/2"	3/4"	1"	1.1/2"	2"
A ₁	Distancia entre caras SW	89	89	105	121	133
K	Abierta	259	259	282	402	402
L	Cerrada	236	236	252	347	347
M	Diám. volante	108	108	108	140	203
X	Profundidad paso SW	13	13	13	13	16
Y	Diámetro paso SW	27	27	34	49	61
	Peso (kg.)	4,1	4,1	6,4	10,9	17,7

COMPUERTA ALQUILACIÓN 150LBS UOP 1.1/2" - 36"

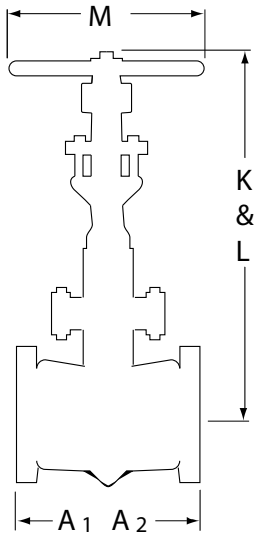

CRANE® PACIFIC Compuerta Fig. 150-HF8		Diseño: API 900
VÁLVULA COMPUERTA PARA SERVICIOS DE ALQUILACIÓN		
Especificaciones		
Material cuerpo	Acero carbono ASTM A216 Gr. WCB	
Asientos	Monel®	
Conexiones	Bridas, Roscadas o Socket Weld	
Rating	150LBS	
Pruebas	API 598 y API 622 "Packing Emission" para válvulas de proceso	
Fire Safe	Según API 607 (última edición)	
Presión prueba	Cuerpo: 450 psig Asiento: 320 psig Cuerpo (helio): 450 psig	
Aplicaciones	Fundamentalmente en la industria Petroquímica	

Componentes		
Pos.	Denominación	Material
10	Cuerpo	Acero carbono ASTM A216 Gr. WCB
11	Asiento	Monel® 400
16a	Tuerca	ASTM A194 Gr. 2HM
16b	Tuerca	ASTM A194 Gr. 2H
20	Cojinetes	Acero aleado
30	Tapa	ASTM A216 Gr. WCB
31	Tuerca guía husillo	Bronce-Aluminio
32	Casquillo husillo	Monel®
35	Prensaestopas	Monel®
36	Brida prensaestopas	Acero carbono
46	Empaquetadura	Grafito
49	Pasador	Acero carbono
50	Volante	Hierro maleable
52	Tornillo de ojo	Acero carbono
54	Tuerca volante	Acero carbono
55*	Junta cuerpo-tapa	Corrugada Acero / PTFE
56	Contratuerca	Acero carbono
70	Husillo	Monel®
71	Cuña	Monel®
98	Espárrago	ASTM A193 Gr. B7M

* Válvulas de 1.1/2" a 3" llevan junta espirometálica en Monel® / Grafito

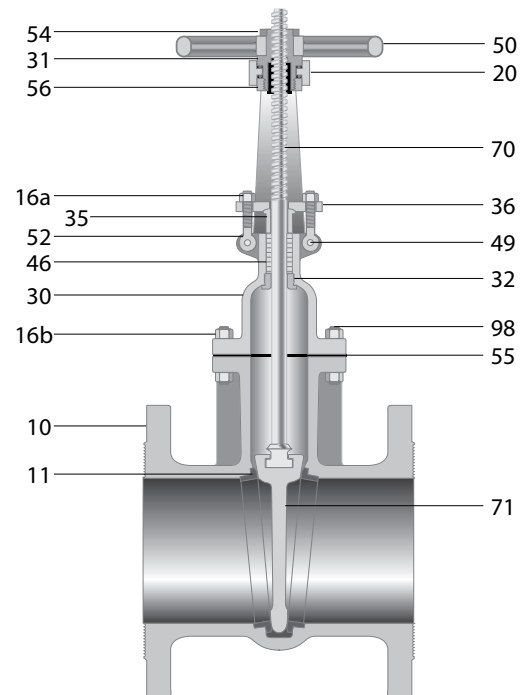

FIG. 150-HF8 - COMPUERTA ALQUILACIÓN 150LBS BRIDAS UOP

DIM.	DESCRIPCIÓN	TAMAÑO VÁLVULA															
		1.1/2"	2"	2.1/2"	3"	4"	6"	8"	10"	12"	14"	16"	18"	20"	24"	30"	36"
A ₁	Distancia entre caras RF	165	178	191	203	229	267	292	330	356	381	406	432	457	508	610	711
A ₂	Distancia entre caras RTJ	178	191	203	216	241	279	305	343	368	394	419	445	470	521	622	724
K	Abierta	442	451	491	491	716	873	1108	1308	1468	1598	1841	2008	2198	2618	3556	3937
L	Cerrada	386	391	408	408	595	703	880	1020	1154	1236	1435	1560	1708	2032	2794	3023
M	Diám. volante	254	254	254	254	254	356	356	610	610	610	610	711	711	864	864	864
	Peso (kg.)	29	31	54	58	62	106	160	269	366	477	606	860	1010	1518	2787	3700

VÁLVULAS PARA ALQUILACIÓN

COMPUERTA ALQUILACIÓN 300LBS UOP 1.1/2" - 36"

CRANE® PACIFIC Compuerta Fig. 350-HF8		Diseño: API 600
VÁLVULA COMPUERTA PARA SERVICIOS DE ALQUILACIÓN		
Especificaciones		
Material cuerpo	ASTM A216 Gr. WCB	
Asientos	Monel®	
Conexiones	Bridas, Roscadas o Socket Weld	
Rating	300LBS	
Pruebas	API 598 y API 622 "Packing Emission" para válvulas de proceso	
Fire Safe	Según API 607 (última edición)	
Presión prueba	Cuerpo: 1125 psig Asiento: 825 psig Cuerpo (helio): 500 psig	
Aplicaciones	Fundamentalmente en la industria Petroquímica	

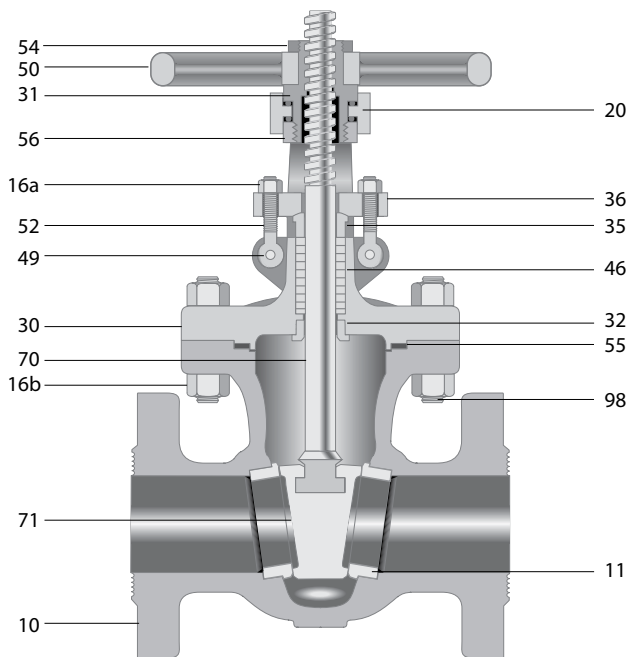
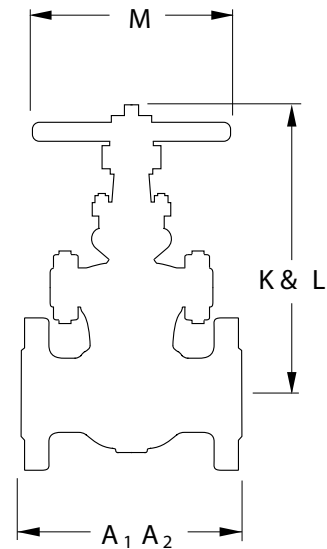

Componentes		
Pos.	Denominación	Material
10	Cuerpo	ASTM A216 Gr. WCB
11	Asientos	Monel®
16b	Tuerca	ASTM A194 Gr. 2HM
16a	Tuerca	ASTM A194 Gr. 2H
20	Cojinetes	Acero aleado
30	Tapa	ASTM A216 Gr. WCB
31	Tuerca guía husillo	Bronce-Aluminio
32	Casquillo husillo	Monel®
35	Prensaestopas	Monel®
36	Brida prensaestopas	Acero carbono
46	Empaquetadura	Grafito
49	Pasador	Acero carbono
50	Volante	Hierro maleable
52	Tornillo de ojo	Acero carbono
54	Tuerca volante	Acero carbono
55	Junta cuerpo-tapa	Espirometálica Monel® / Grafito
56	Contratuerca	Acero carbono
70	Husillo	Monel®
71	Cuña	Monel®
98	Espárrago	ASTM A193 Gr. B7M

FIG. 350-HF8 - COMPUERTA ALQUILACIÓN 300LBS BRIDAS UOP

DIM.	DESCRIPCIÓN	TAMAÑO VÁLVULA															
		1.1/2"	2"	2.1/2"	3"	4"	6"	8"	10"	12"	14"	16"	18"	20"	24"	30"	36"
A ₁	Distancia entre caras RF	191	216	241	283	305	403	419	457	502	762	838	914	991	1143	1397	1727
A ₂	Distancia entre caras RTJ	203	232	257	299	321	419	435	473	518	778	854	930	1007	1165	1422	1756
K	Abierta	442	451	491	491	715	918	1115	1297	1468	1684	1835	2008	2245	2602	3505	3962
L	Cerrada	386	391	408	408	595	743	883	1022	1141	1324	1432	1557	1740	1988	2743	3073
M	Diám. volante	254	254	254	254	356	457	610	610	610	610	711	711	711	864	864	864
	Peso (kg.)	30	32	57	61	98	175	297	453	597	868	1182	1504	1938	3411	4907	6940

COMPUERTA ALQUILACIÓN 300LBS UOP 1.1/2" - 36"

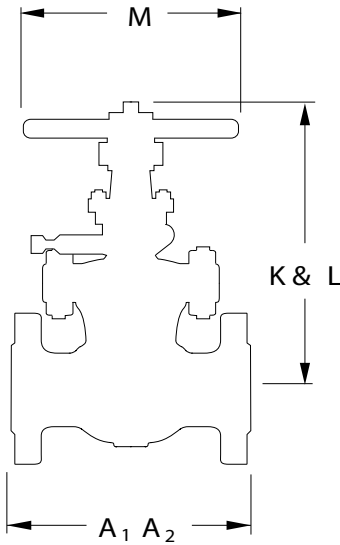

CRANE® PACIFIC Compuerta Fig. 350GR-HF8T		Diseño: API 600
VÁLVULA COMPUERTA PARA SERVICIOS DE ALQUILACIÓN		
Especificaciones		
Material cuerpo	Acero carbono ASTM A216 Gr. WCB	
Asientos	Monel® con inserto de PTFE	
Conexiones	Bridas, Roscadas o Socket Weld	
Rating	300LBS	
Pruebas	API 598 y API 622 "Packing Emission" para válvulas de proceso	
Fire Safe	Según API 607 (última edición)	
Presión prueba	Cuerpo: 1125 psig Asiento: 825 psig Cuerpo (helio): 500 psig	
Aplicaciones	Fundamentalmente en la industria Petroquímica	

Componentes		
Pos.	Denominación	Material
10	Cuerpo	Acero carbono ASTM A216 Gr. WCB
11	Asiento	Monel® con inserto de PTFE
16b	Tuerca	ASTM A194 Gr. 2HM
16a	Tuerca	ASTM A194 Gr. 2H
20	Cojinetes	Acero aleado
21	Juego de tornillos	Acero aleado
30	Tapa	ASTM A216 Gr. WCB
31	Tuerca guía husillo	Bronce-Aluminio
32	Casquillo husillo	Monel®
33	Linterna	Monel®
35	Prensaestopas	Monel®
36	Brida prensaestopas	Acero carbono
46	Empaquetadura	Grafito
49	Pasador	Acero carbono
50	Volante	Hierro maleable
52	Tornillo de ojo	Acero carbono
54	Tuerca volante	Acero carbono
55	Junta cuerpo-tapa	Anillo de acero dulce
56	Contratuerca	Acero carbono
70	Husillo	Monel®
71	Cuña	Monel®
98	Espárrago	ASTM A193 Gr. B7M
150	Inyector grasa	Acero carbono y Monel®

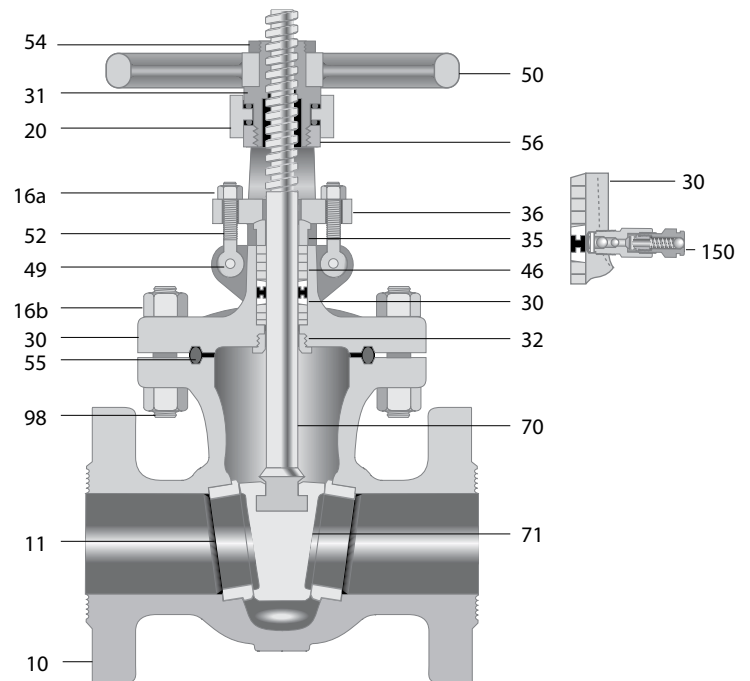

FIG. 350GR-HF8T - COMPUERTA ALQUILACIÓN 300LBS BRIDAS UOP

DIM.	DESCRIPCIÓN	TAMAÑO VÁLVULA															
		1.1/2"	2"	2.1/2"	3"	4"	6"	8"	10"	12"	14"	16"	18"	20"	24"	30"	36"
A ₁	Distancia entre caras RF	191	216	241	283	305	403	419	457	502	762	838	914	991	1143	1397	1727
A ₂	Distancia entre caras RTJ	203	232	257	299	321	419	435	473	518	778	854	930	1007	1165	1422	1756
K	Abierta	442	451	491	491	715	918	1115	1297	1468	1684	1835	2008	2245	2602	3505	3962
L	Cerrada	386	391	408	408	595	743	883	1022	1141	1324	1432	1557	1740	1988	2743	3073
M	Diám. volante	254	254	254	254	356	457	610	610	610	610	711	711	711	864	864	864
	Peso (kg.)	30	32	57	61	98	175	297	453	597	868	1182	1504	1938	3411	4907	6940

VÁLVULAS PARA ALQUILACIÓN

COMPUERTA ALQUILACIÓN 300LBS UOP 1.1/2" - 36"

CRANE® PACIFIC Compuerta Fig. 350GR-HF8-BTT		Diseño: API 600
VÁLVULA COMPUERTA PARA SERVICIOS DE ALQUILACIÓN		
Especificaciones		
Material cuerpo	ASTM A216 Gr. WCB	
Asientos	Monel®	
Conexiones	Bridas, Roscadas o Socket Weld	
Rating	300LBS	
Pruebas	API 598 y API 622 "Packing Emission" para válvulas de proceso	
Fire Safe	Según API 607 (última edición)	
Presión prueba	Cuerpo: 1125 psig Asiento: 825 psig Cuerpo (helio): 500 psig	
Aplicaciones	Fundamentalmente en la industria Petroquímica	

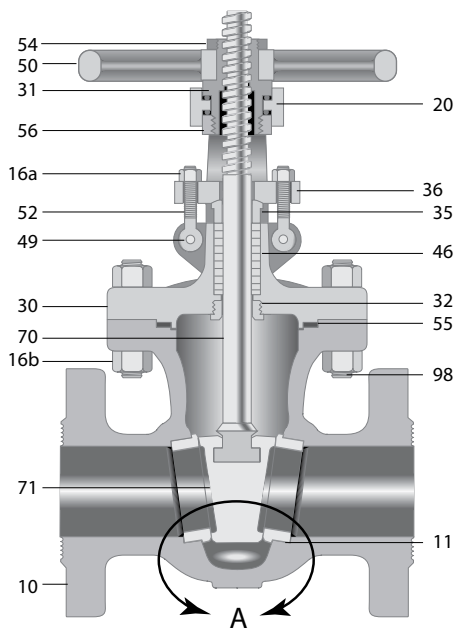
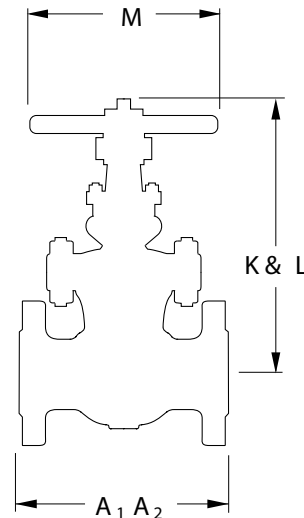

La Figura 350 L (2) P-HF8 lleva camisa de Monel® que cubre la caja prensaestopas

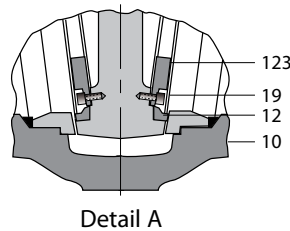

Componentes		
Pos.	Denominación	Material
10	Cuerpo	ASTM A216 Gr. WCB
11	Asientos	Monel®
16b	Tuerca	ASTM A194 Gr. 2HM
16a	Tuerca	ASTM A194 Gr. 2HM
20	Cojinetes	Acero aleado
21	Juego de tornillos	Acero aleado
30	Tapa	ASTM A216 Gr. WCB
31	Tuerca guía husillo	Bronce-Aluminio
32	Casquillo husillo	Monel®
33	Linterna	Monel®
35	Prensaestopas	Monel®
36	Brida prensaestopas	Acero carbono
46	Empaquetadura	Grafito
49	Pasador	Acero carbono
50	Volante	Hierro maleable
52	Tornillo de ojo	Acero carbono
54	Tuerca volante	Acero carbono
55	Junta cuerpo-tapa	Anillo acero dulce
56	Contratuerca	Acero carbono
70	Husillo	Monel®
71	Cuña	Monel®
98	Espárrago	ASTM A193 Gr. B7M
150	Inyector grasa	Acero carbono y Monel®
123	Anillo compresión	Monel®
19	Tornillo	K-Monel® 500
12	Inserto	PTFE

FIG. 350-HF8 - COMPUERTA ALQUILACIÓN 300LBS BRIDAS UOP

DIM.	DESCRIPCIÓN	TAMAÑO VÁLVULA															
		1.1/2"	2"	2.1/2"	3"	4"	6"	8"	10"	12"	14"	16"	18"	20"	24"	30"	36"
A ₁	Distancia entre caras RF	191	216	241	283	305	403	419	457	502	762	838	914	991	1143	1397	1727
A ₂	Distancia entre caras RTJ	203	232	257	299	321	419	435	473	518	778	854	930	1007	1165	1422	1756
K	Abierta	442	451	491	491	715	918	1115	1297	1468	1684	1835	2008	2245	2602	3505	3962
L	Cerrada	386	391	408	408	595	743	883	1022	1141	1324	1432	1557	1740	1988	2743	3073
M	Diám. volante	254	254	254	254	356	457	610	610	610	610	711	711	711	864	864	864
	Peso (kg.)	30	32	57	61	98	175	297	453	597	868	1182	1504	1938	3411	4907	6940

GLOBO ALQUILACIÓN 300LBS UOP 1/2" - 2"

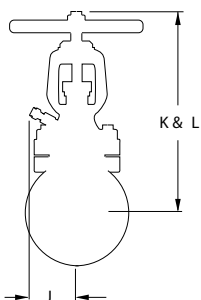
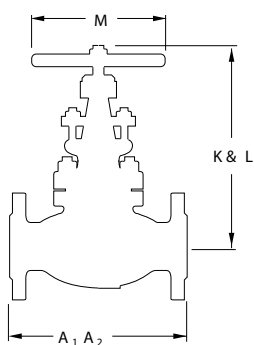

CRANE® PACIFIC Globo Fig. 3367G-HF8T		Diseño: API 600
VÁLVULA GLOBO PARA SERVICIOS DE ALQUILACIÓN		
Especificaciones		
Material cuerpo	Acero carbono ASTM A216 Gr. WCB	
Obturador	Monel® con inserto de PTFE	
Conexiones	Bridas, Roscadas o Socket Weld	
Rating	300LBS	
Pruebas	API 598 y API 622 "Packing Emission" para válvulas de proceso	
Fire Safe	Según API 607 (última edición)	
Presión prueba	Cuerpo: 1125 psig Asiento: 825 psig Cuerpo (helio): 500 psig	
Aplicaciones	Fundamentalmente en la industria Petroquímica	

Pos.	Denominación	Componentes	
		Material	
54	Tuerca volante	Acero carbono	
50	Volante	Fundición Dúctil	
31	Tuerca guía husillo	12% Cromo	
52	Tornillo de ojo	Acero carbono	
16a	Tuerca	Acero carbono	
36	Brida prensaestopas	Acero carbono	
35	Prensaestopas	Monel®	
49	Pasador	Acero carbono	
16b	Tuerca	ASTM A194 Gr. 2HM	
30	Tapa	ASTM A216 Gr. WCB	
55	Junta cuerpo-tapa	Espirometálica Monel® / Grafito	
10	Cuerpo	ASTM A216 Gr. WCB	
70	Husillo	K-Monel®	
46	Empaquetadura	Grafito	
150	Inyector grasa	Acero carbono y Monel®	
33	Linterna	Monel®	
72	Tuerca obturador	Monel®	
113	Pletina empuje	Monel®	
71	Obturador	Monel® con inserto de PTFE	
11	Asiento	Monel®	
98	Espárrago	ASTM A193 Gr. B7M	

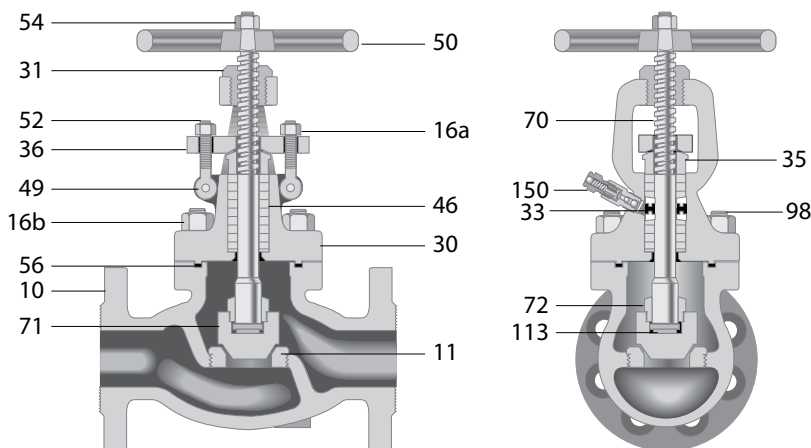

FIG. 3367G-HF8T - GLOBO ALQUILACIÓN 300LBS BRIDAS UOP

DIM.	DESCRIPCIÓN	TAMAÑO VÁLVULA						
		1/2"	3/4"	1"	1.1/4"	1.1/2"	2"	
A ₁	Distancia entre caras RF	152	1178	203	216	229	267	
A ₂	Distancia entre caras RTJ	164	191	216	229	241	283	
J	Dist. centro al inyector	86	89	89	89	89	92	
K	Abierta	206	229	244	305	349	359	
L	Cerrada	187	219	225	286	308	327	
M	Diám. volante	89	114	114	203	203	203	
	Peso (kg.)	4,5	6,8	10,0	16,3	20,0	28,6	

VÁLVULAS PARA ALQUILACIÓN

GLOBO ALQUILACIÓN 600LBS UOP 1/2" - 1"

CRANE® PACIFIC Globo Fig. 665-HF8 (-M35-1)		Diseño: API 600
VÁLVULA GLOBO PARA SERVICIOS DE ALQUILACIÓN		
Especificaciones		
Material cuerpo	ASTM A216 Gr. WCB y ASTM A494 Gr. M35-1	
Obturador	Monel®	
Conexiones	Bridas, Roscadas o Socket Weld	
Rating	600LBS	
Pruebas	API 598 y API 622 "Packing Emission" para válvulas de proceso	
Fire Safe	Según API 607 (última edición)	
Presión prueba	Fig. 665-HF8 Cuerpo: 2250 psig Asiento: 1650 psig Cuerpo (helio): 500 psig	Fig. 665-HF8 (-M35-1) Cuerpo: 2175 psig Asiento: 1600 psig Cuerpo (helio): 500 psig
Aplicaciones	Fundamentalmente en la industria Petroquímica	

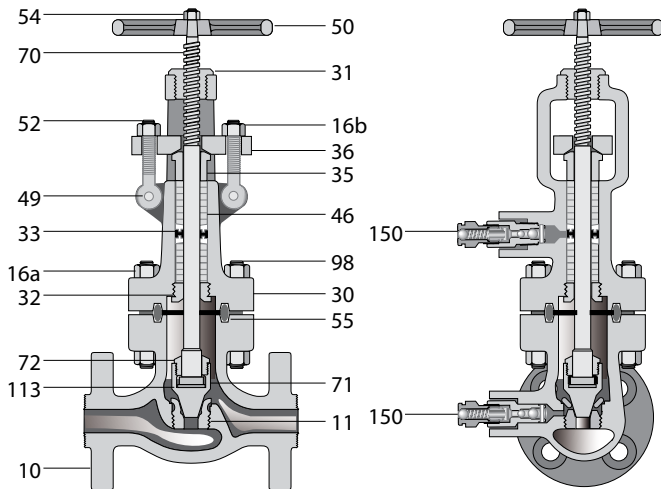
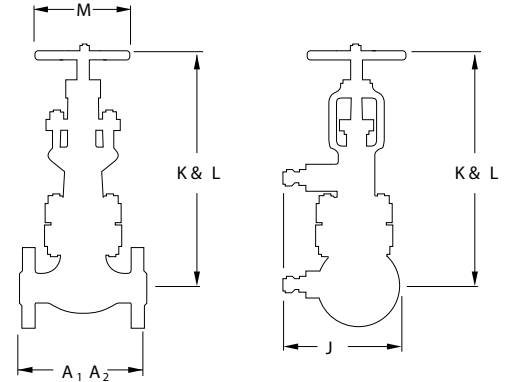

Pos.	Denominación	Componentes	
		Fig. 665-HF8	Fig. 665-HF8 (-M35-1)
		Material	
54	Tuerca volante	Acero carbono	Acero carbono
70	Husillo	K-Monel®	K-Monel®
50	Volante	Hierro maleable	Hierro maleable
31	Tuerca guía husillo	12% Cromo	12% Cromo
52	Tornillo de ojo	Acero carbono	Acero carbono
16b	Tuerca	Acero carbono	Acero carbono
36	Brida prensaestopas	Acero carbono	Acero carbono
35	Prensaestopas	Monel®	Monel®
49	Pasador	Acero carbono	Acero carbono
46	Empaquetadura	Grafito	Grafito
33	Linterna	Monel®	Monel®
98	Espárrago	ASTM A193 Gr. B7M	ASTM A193 Gr. B7M
16a	Tuerca	ASTM A194 Gr. 2HM	ASTM A194 Gr. 2HM
30	Tapa	ASTM A216 Gr. WCB	ASTM A494 Gr. M35-1
55	Junta cuerpo-tapa	Anillo acero dulce	Anillo Monel®
32	Casquillo husillo	Monel®	Monel®
150	Inyector grasa	Acero carbono y Monel®	Acero carbono y Monel®
72	Tuerca obturador	Monel®	Monel®
71	Obturador	Monel®	Monel®
113	Pletina empuje	Monel®	Monel®
11	Asiento	Monel®	Monel®
10	Cuerpo	ASTM A216 Gr. WCB	ASTM A494 Gr. M35-1

FIG. 665-HF8 (-M35-1) - GLOBO ALQUILACIÓN 600LBS BRIDAS UOP

DIM.	DESCRIPCIÓN	TAMAÑO VÁLVULA		
		1/2"	3/4"	1"
A ₁	Distancia entre caras RF	165	191	216
A ₂	Distancia entre caras RTJ	164	191	216
J	Dist. centro al inyector	108	108	108
K	Abierta	330	371	356
L	Cerrada	321	346	324
M	Diám. volante	114	140	140
	Peso (kg.)	10	14,1	19,1

GLOBO ALQUILACIÓN 600LBS UOP 1/2" - 2"

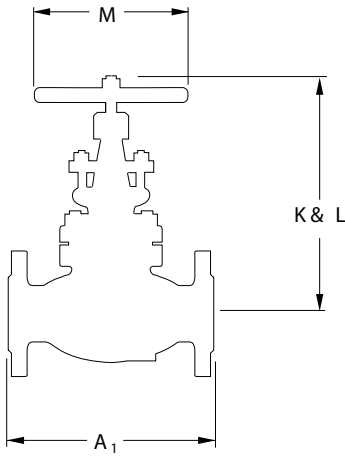

CRANE® PACIFIC Globo Fig. 3667G-HF8 (-M35-1)		Diseño: API 600
VÁLVULA GLOBO PARA SERVICIOS DE ALQUILACIÓN		
Especificaciones		
Material cuerpo	ASTM A494 Gr. M35-1	
Obturador	Monel®	
Conexiones	Bridas, Roscadas o Socket Weld	
Rating	600LBS	
Pruebas	API 598 y API 622 "Packing Emission" para válvulas de proceso	
Fire Safe	Según API 607 (última edición)	
Presión prueba	Cuerpo: 2250 psig Asiento: 1650 psig Cuerpo (helio): 500 psig	
Aplicaciones	Fundamentalmente en la industria Petroquímica	

Componentes		
Pos.	Denominación	Material
10	Cuerpo	ASTM A494 Gr. M35-1
11	Asiento	Monel®
16a	Tuerca	Acero carbono
16b	Tuerca	ASTM A194 Gr. 2HM
30	Tapa	ASTM A494 Gr. M35-1
31	Tuerca guía husillo	12% Cromo
35	Prensaestopas	Monel®
36	Brida prensaestopas	Acero carbono
46	Empaquetadura	Grafito
49	Pasador	Acero carbono
50	Volante	Hierro maleable
52	Tornillo de ojo	Acero carbono
54	Volante	Acero carbono
55	Junta cuerpo-tapa	Espirimetálica Monel® / Grafito
70	Husillo	K-Monel®
71	Disco	Monel®
72	Tuerca obturador	Monel®
113	Pletina empuje	Monel®
98	Espárrago	ASTM A193 Gr. B7M

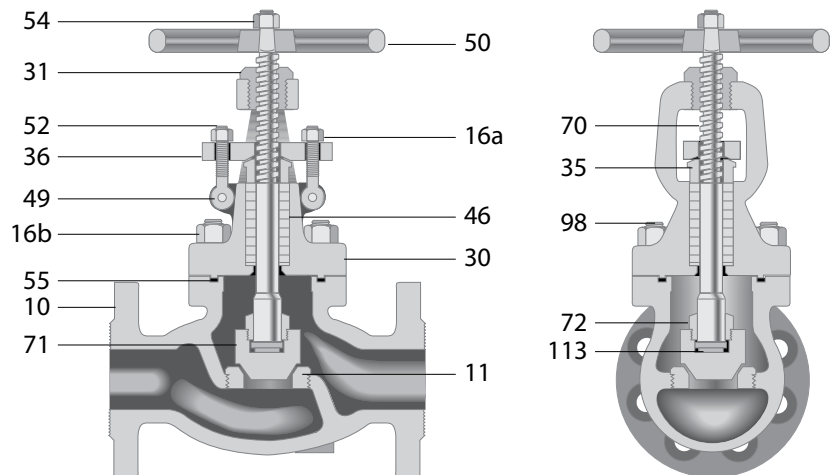

FIG. 3667G-HF8 (-M35-1) - GLOBO ALQUILACIÓN 600LBS BRIDAS UOP

DIM.	DESCRIPCIÓN	TAMAÑO VÁLVULA				
		1/2"	3/4"	1"	1.1/2"	2"
A ₁	Distancia entre caras Bridas	165	191	216	241	292
K	Abierta	206	229	244	350	359
L	Cerrada	187	219	225	308	327
M	Diám. volante	89	114	114	203	203
	Peso (kg.)	4,5	6,8	10,0	20,0	28,6

VÁLVULAS PARA ALQUILACIÓN

GLOBO ALQUILACIÓN 800LBS UOP 1/2" - 1"

CRANE® PACIFIC Globo Fig. 667-HF8		Diseño: API 600
VÁLVULA GLOBO PARA SERVICIOS DE ALQUILACIÓN		
Especificaciones		
Material cuerpo	Acero carbono ASTM A216 Gr. WCB	
Obturador	Monel®	
Conexiones	Bridas, Roscadas o Socket Weld	
Rating	800LBS	
Pruebas	API 598 y API 622 "Packing Emission" para válvulas de proceso	
Fire Safe	Según API 607 (última edición)	
Presión prueba	Cuerpo: 3000 psig Asiento: 2200 psig Cuerpo (helio): 500 psig	
Aplicaciones	Fundamentalmente en la industria Petroquímica	

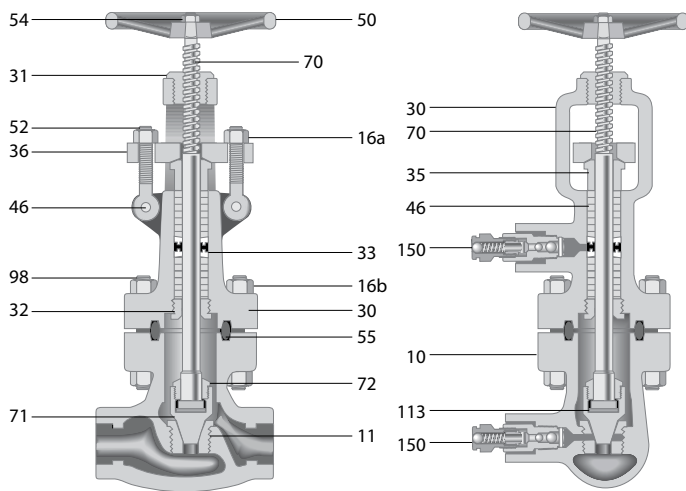
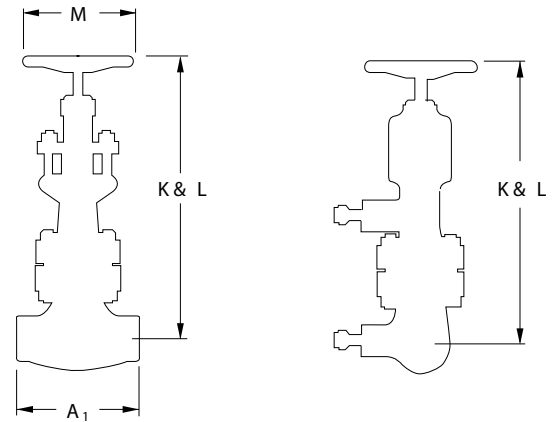

Componentes		
Pos.	Denominación	Material
54	Tuerca volante	Acero carbono
50	Volante	Hierro maleable
31	Tuerca guía husillo	12% Cromo
52	Tornillo ojo	Acero carbono
16a	Tuerca	Acero carbono
36	Brida prensaestopas	Acero carbono
46	Pasador	Acero carbono
98	Espárrago	ASTM A193 Gr. B7M
16b	Tuerca	ASTM A194 Gr. 2HM
32	Casquillo husillo	Monel®
55	Junta cuerpo-tapa	Anillo acero dulce
72	Tuerca obturador	Monel®
71	Obturador	Monel®
11	Asiento	Monel®
30	Tapa	ASTM A216 Gr. WCB
70	Husillo	K-Monel®
35	Prensaestopas	Monel®
46	Empaquetadura	Grafito
150	Inyector grasa	Acero carbono y Monel®
33	Linterna	Monel®
10	Cuerpo	ASTM A216 Gr. WCB
113	Pletina empuje	Monel®

FIG. 667-HF8 - GLOBO ALQUILACIÓN 800LBS SW UOP

DIM.	DESCRIPCIÓN	TAMAÑO VÁLVULA		
		1/2"	3/4"	1"
A ₁	Distancia entre caras SW	114	131	131
K	Abierta	305	352	352
L	Cerrada	295	327	327
M	Diám. volante	114	140	140
X	Profundidad paso SW	10	13	13
Y	Diámetro paso SW	22	27	32
	Peso (kg.)	8,2	11,3	14,5

GLOBO ALQUILACIÓN 800LBS UOP 1/2" - 2"

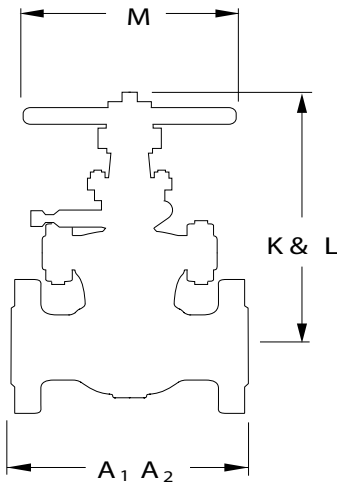

CRANE® PACIFIC Globo Fig. 3669-HF8		Diseño: API 602
VÁLVULA GLOBO PARA SERVICIOS DE ALQUILACIÓN		
Especificaciones		
Material cuerpo	ASTM A216 Gr. WCB o ASTM A105	
Obturador	Monel®	
Conexiones	Bridas, Roscadas o Socket Weld	
Rating	800LBS	
Pruebas	API 598 y API 622 "Packing Emission" para válvulas de proceso	
Fire Safe	Según API 607 (última edición)	
Presión prueba	Cuerpo: 3000 psig Asiento: 2200 psig Cuerpo (helio): 500 psig	
Aplicaciones	Fundamentalmente en la industria Petroquímica	

Componentes		
Pos.	Denominación	Material
10	Cuerpo	ASTM A216 Gr. WCB o ASTM A105
11	Asiento	Monel®
16a	Tuerca	ASTM A194 Gr. 2H
16b	Tuerca	ASTM A194 Gr. 2HM
30	Tapa	ASTM A216 Gr. WCB o ASTM A105
31	Tuerca guía husillo	12% Cromo
35	Prensaestopas	Monel®
36	Brida prensaestopas	Acero carbono
46	Empaquetadura	Grafito
49	Pasador	Acero carbono
50	Volante	Hierro maleable
52	Tornillo ojo	Acero carbono
54	Tuerca volante	Acero carbono
55	Junta cuerpo-tapa	Espirometálica Monel® / Grafito
70	Husillo	K-Monel®
71	Obturador	Monel®
72	Tuerca obturador	Monel®
98	Espárrago	ASTM A193 Gr. B7M
113	Pletina empuje	Monel®

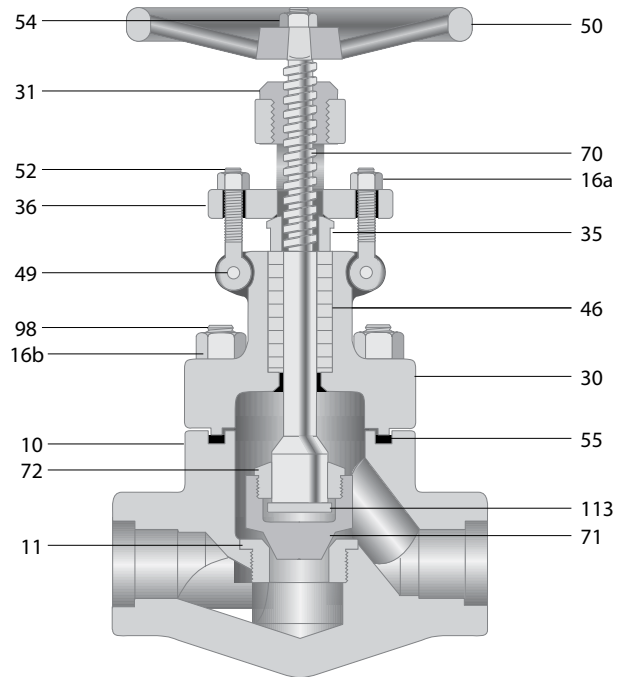

FIG. 3669-HF8 - GLOBO ALQUILACIÓN 800LBS SW UOP

DIM.	DESCRIPCIÓN	TAMAÑO VÁLVULA					
		1/2"	3/4"	1"	1.1/4"	1.1/2"	2"
A ₁	Distancia entre caras SW	114	114	130	159	178	213
K	Abierta	220	220	242	299	334	362
L	Cerrada	213	213	226	286	309	331
M	Diám. volante	114	114	114	203	203	203
X	Profundidad paso SW	13	13	13	13	13	16
Y	Diámetro paso SW	27	27	34	43	49	61
	Peso (kg.)	4,1	4,1	5,9	11,8	13,6	22,2

VÁLVULAS PARA ALQUILACIÓN

GLOBO ALQUILACIÓN 800LBS UOP 1/2" - 2"

CRANE® PACIFIC Globo Fig. 3669G-HF8T		Diseño: API 602
VÁLVULA GLOBO PARA SERVICIOS DE ALQUILACIÓN		
Especificaciones		
Material cuerpo	ASTM A216 Gr. WCB o ASTM A105	
Obturador	Monel® con inserto de PTFE	
Conexiones	Bridas, Roscadas o Socket Weld	
Rating	800LBS	
Pruebas	API 598 y API 622 "Packing Emission" para válvulas de proceso	
Fire Safe	Según API 607 (última edición)	
Presión prueba	Cuerpo: 3000 psig Asiento: 2200 psig Cuerpo (helio): 500 psig	
Aplicaciones	Fundamentalmente en la industria Petroquímica	

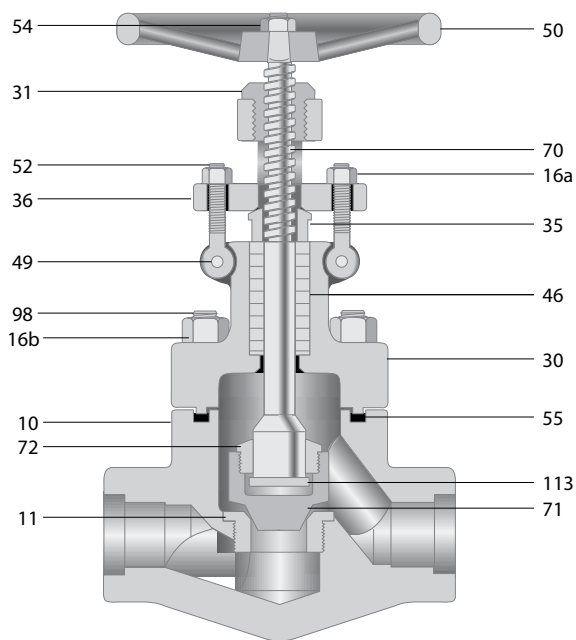
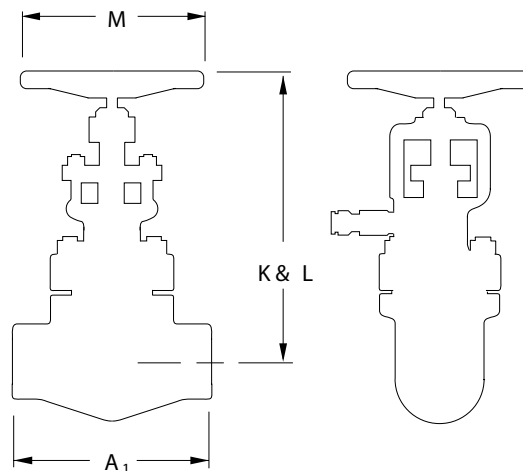

Componentes		
Pos.	Denominación	Material
54	Tuerca volante	Acero carbono
50	Volante	Hierro maleable
70	Husillo	K-Monel®
31	Tuerca guía husillo	12% Cromo
52	Tornillo ojo	Acero carbono
16a	Tuerca	Acero carbono
36	Brida prensaestopas	Acero carbono
35	Prensaestopas	Monel®
49	Pasador	Acero carbono
46	Empaquetadura	Grafito
98	Espárrago	ASTM A193 Gr. B7M
16b	Tuerca	ASTM A194 Gr. 2HM
30	Tapa	ASTM A216 Gr. WCB o ASTM A105
55	Junta cuerpo-tapa	Espirometálica Monel® / Grafito
72	Tuerca obturador	Monel®
71	Obturador	Monel® con inserto de PTFE
33	Linterna	Monel®
150	Inyector grasa	Acero carbono
10	Cuerpo	ASTM A216 Gr. WCB o ASTM A105
11	Asiento	Monel®

FIG. 3669-HF8T - GLOBO ALQUILACIÓN 800LBS SW UOP

DIM.	DESCRIPCIÓN	TAMAÑO VÁLVULA				
		1/2"	3/4"	1"	1.1/2"	2"
A ₁	Distancia entre caras SW	114	114	130	178	213
K	Abierta	220	220	242	334	362
L	Cerrada	213	213	226	309	331
M	Diám. volante	114	114	114	203	203
X	Profundidad paso SW	13	13	13	13	16
Y	Diámetro paso SW	27	27	34	49	61
	Peso (kg.)	4,1	4,1	5,9	13,6	22,2

GLOBO ALQUILACIÓN 150LBS UOP 1.1/2" - 12"

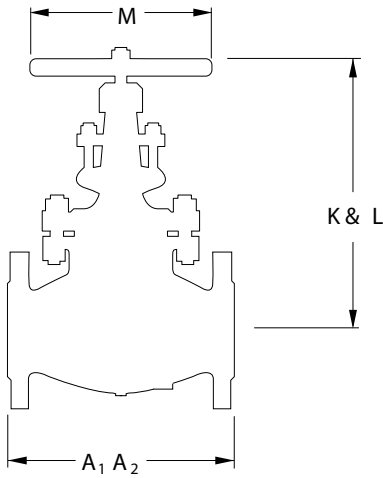

CRANE® PACIFIC Globo Fig. 160-HF8		Diseño: API 600
VÁLVULA GLOBO PARA SERVICIOS DE ALQUILACIÓN		
Especificaciones		
Material cuerpo	Acero carbono ASTM A216 Gr. WCB	
Obturador	Monel®	
Conexiones	Bridas, Roscadas o Socket Weld	
Rating	150LBS	
Pruebas	API 598 y API 622 "Packing Emission" para válvulas de proceso	
Fire Safe	Según API 607 (última edición)	
Presión prueba	Cuerpo: 450 psig Asiento: 320 psig Cuerpo (helio): 450 psig	
Aplicaciones	Fundamentalmente en la industria Petroquímica	

Componentes		
Pos.	Denominación	Material
54	Tuerca volante	Acero carbono
50	Volante	Fundición Dúctil
31	Tuerca guía husillo	Bronce-Aluminio
70	Husillo	Monel®
52	Tornillo ojo	Acero carbono
16a	Tuerca	Acero carbono
36	Brida prensaestopas	Acero carbono
35	Prensaestopas	Monel®
49	Pasador	Acero carbono
30	Tapa	ASTM A216 Gr. WCB
46	Empaquetadura	Grafito
55	Junta cuerpo-tapa	Corrugada Acero dulce / PTFE
32	Casquillo husillo	Monel®
72	Tuerca obturador	Monel®
11	Asiento	Monel®
113	Pletina empuje	Monel®
71	Obturador	Monel®
10	Cuerpo	ASTM A216 Gr. WCB
98	Espárrago	ASTM A193 Gr. B7M
16b	Tuerca	ASTM A194 Gr. 2HM
85	Arandela volante	12% Cromo

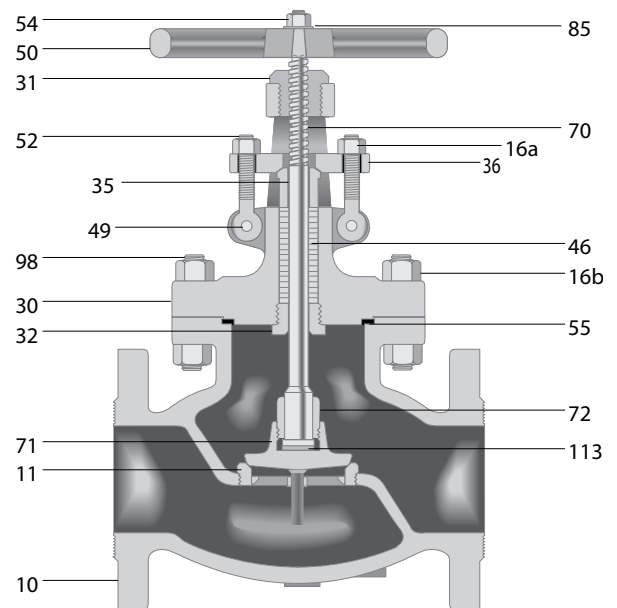

FIG. 160-HF8 - GLOBO ALQUILACIÓN 150LBS BRIDAS UOP

DIM.	DESCRIPCIÓN	TAMAÑO VÁLVULA									
		1.1/2"	2"	2.1/2"	3"	4"	6"	8"	10"	12"	
A ₁	Distancia entre caras RF	165	203	216	241	292	406	495	622	699	
A ₂	Distancia entre caras RTJ	178	216	229	254	305	419	508	635	711	
K	Abierta	311	375	397	416	498	651	727	749	895	
L	Cerrada	289	343	365	375	448	584	660	683	794	
M	Diám. volante	203	203	254	254	254	356	457	457	457	
	Peso (kg.)	14	23	32	38	63	108	186	271	374	

VÁLVULAS PARA ALQUILACIÓN

GLOBO ALQUILACIÓN 300LBS UOP 1.1/2" - 12"

CRANE® PACIFIC Globo Fig. 360-HF8		Diseño: API 600
VÁLVULA GLOBO PARA SERVICIOS DE ALQUILACIÓN		
Especificaciones		
Material cuerpo	Acero carbono ASTM A216 Gr. WCB	
Obturador	Monel®	
Conexiones	Bridas, Roscadas o Socket Weld	
Rating	300LBS	
Pruebas	API 598 y API 622 "Packing Emission" para válvulas de proceso	
Fire Safe	Según API 607 (última edición)	
Presión prueba	Cuerpo: 1125 psig Asiento: 825 psig Cuerpo (helio): 500 psig	
Aplicaciones	Fundamentalmente en la industria Petroquímica	

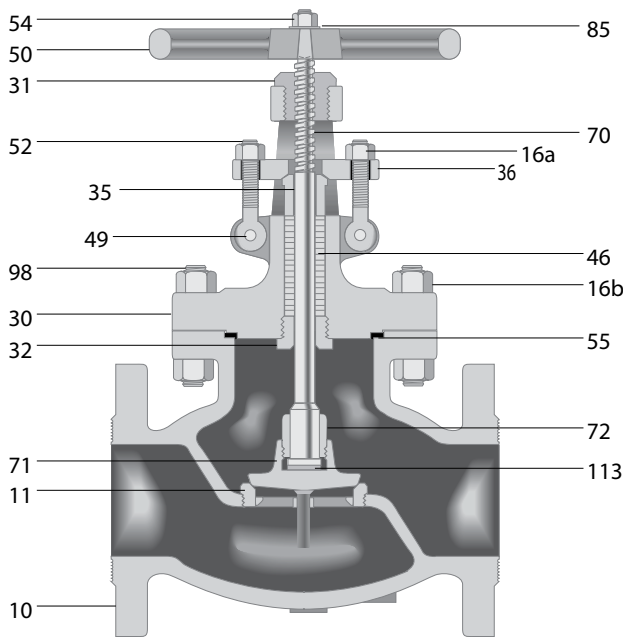
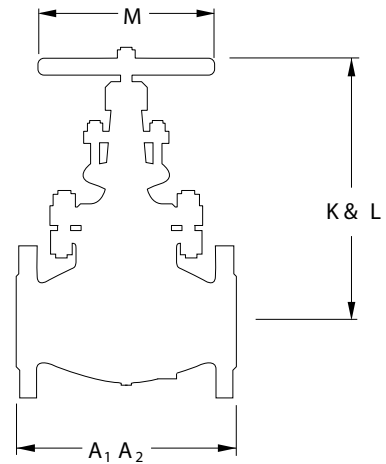

Componentes		
Pos.	Denominación	Material
54	Tuerca volante	Acero carbono
50	Volante	Fundición Dúctil
31	Tuerca guía husillo	Bronce-Aluminio
70	Husillo	Monel®
52	Tornillo ojo	Acero carbono
16a	Tuerca	Acero carbono
36	Brida prensaestopas	Acero carbono
35	Prensaestopas	Monel®
49	Pasador	Acero carbono
30	Tapa	ASTM A216 Gr. WCB
46	Empaquetadura	Grafito
55	Junta cuerpo-tapa	Corrugada Acero dulce / PTFE
32	Casquillo husillo	Monel®
72	Tuerca obturador	Monel®
11	Recubrimiento asiento	Monel®
113	Pletina empuje	Monel®
71	Obturador	Monel®
10	Cuerpo	ASTM A216 Gr. WCB
98	Espárrago	ASTM A193 Gr. B7M
16b	Tuerca	ASTM A194 Gr. 2HM
85	Arandela volante	12% Cromo

FIG. 360-HF8 - GLOBO ALQUILACIÓN 300LBS BRIDAS UOP

DIM.	DESCRIPCIÓN	TAMAÑO VÁLVULA									
		1.1/2"	2"	2.1/2"	3"	4"	6"	8"	10"	12"	
A ₁	Distancia entre caras RF	229	267	292	318	356	445	559	622	711	
A ₂	Distancia entre caras RTJ	241	283	308	333	371	460	575	638	727	
K	Abierta	397	464	508	527	632	730	797	873	1219	
L	Cerrada	365	435	476	479	581	657	724	800	1143	
M	Diám. volante	203	203	254	254	356	457	457	864	864	
	Peso (kg.)	27	36	47	62	102	176	288	571	770	

GLOBO ALQUILACIÓN 300LBS UOP 1.1/2" - 12"

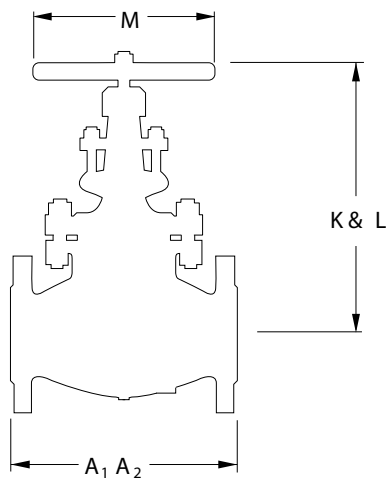

CRANE® PACIFIC Globo Fig. 360GR-HF8T		Diseño: API 600
VÁLVULA GLOBO PARA SERVICIOS DE ALQUILACIÓN		
Especificaciones		
Material cuerpo	Acero carbono ASTM A216 Gr. WCB	
Obturador	Monel® con inserto de PTFE	
Conexiones	Bridas, Roscadas o Socket Weld	
Rating	300LBS	
Pruebas	API 598 y API 622 "Packing Emission" para válvulas de proceso	
Fire Safe	Según API 607 (última edición)	
Presión prueba	Cuerpo: 1125 psig Asiento: 825 psig Cuerpo (helio): 500 psig	
Aplicaciones	Fundamentalmente en la industria Petroquímica	

Componentes		
Pos.	Denominación	Material
54	Tuerca volante	Acero carbono
50	Volante	Fundición Dúctil
31	Tuerca guía husillo	Bronce-Aluminio
70	Husillo	Monel®
52	Tornillo ojo	Acero carbono
16a	Tuerca	Acero carbono
36	Brida prensaestopas	Acero carbono
35	Prensaestopas	Monel®
49	Pasador	Acero carbono
30	Tapa	ASTM A216 Gr. WCB
46	Empaquetadura	Grafito
55	Junta cuerpo-tapa	Anillo Acero dulce
32	Casquillo husillo	Monel®
72	Tuerca obturador	Monel®
11	Asiento	Monel®
113	Pletina empuje	Monel®
71	Obturador	Monel® con inserto de PTFE
10	Cuerpo	ASTM A216 Gr. WCB
98	Espárrago	ASTM A193 Gr. B7M
16b	Tuerca	ASTM A194 Gr. 2HM
150	Inyector grasa	Acero carbono y Monel®
85	Arandela volante	12% Cromo
33	Linterna	Monel®

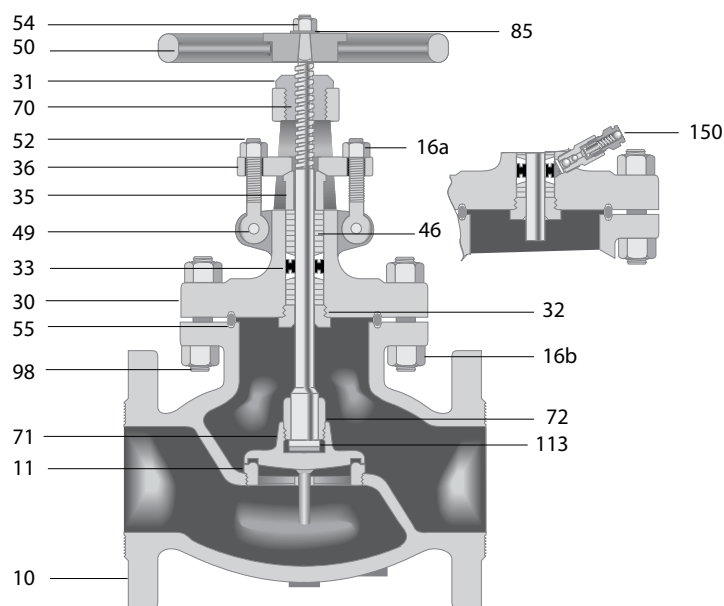

FIG. 360GR-HF8T - GLOBO ALQUILACIÓN 300LBS BRIDAS UOP

DIM.	DESCRIPCIÓN	TAMAÑO VÁLVULA								
		1.1/2"	2"	2.1/2"	3"	4"	6"	8"	10"	12"
A ₁	Distancia entre caras RF	229	267	292	318	356	445	559	622	711
A ₂	Distancia entre caras RTJ	241	283	308	333	371	460	575	638	727
K	Abierta	397	362	394	429	477	601	718	896	1004
L	Cerrada	364	343	372	404	445	556	661	826	921
M	Diám. volante	203	203	254	254	356	457	457	559	559
	Peso (kg.)	27	29	48	56	80	165	271	405	716

VÁLVULAS PARA ALQUILACIÓN

GLOBO ALQUILACIÓN 300LBS UOP 1.1/2" - 8"

CRANE® PACIFIC Globo Fig. 366-HF8 (-M35-1)		Diseño: API 600
VÁLVULA GLOBO PARA SERVICIOS DE ALQUILACIÓN		
Especificaciones		
Material cuerpo	ASTM A216 Gr. WCB y ASTM A494 Gr. M35-1	
Obturador	Monel®	
Conexiones	Bridas, Roscadas o Socket Weld	
Rating	300LBS	
Pruebas	API 598 y API 622 "Packing Emission" para válvulas de proceso	
Fire Safe	Según API 607 (última edición)	
Presión prueba	Fig. 366-HF8 Cuerpo: 1125 psig Asiento: 825 psig Cuerpo (helio): 500 psig	Fig. 366-HF8 (-M35-1) Cuerpo: 1100 psig Asiento: 800 psig Cuerpo (helio): 500 psig
Aplicaciones	Fundamentalmente en la industria Petroquímica	

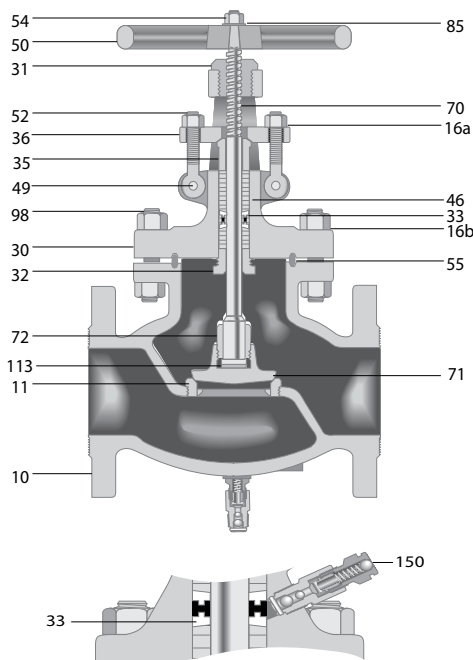
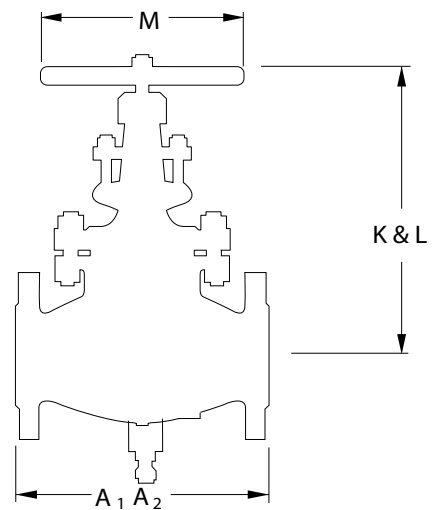

Componentes				
Pos.	Denominación	Fig. 366-HF8	Material	
			Fig. 366-HF8	Fig. 366-HF8 (-M35-1)
54	Tuerca volante	Acero carbono	Acero carbono	Acero carbono
50	Volante	Fundición Dúctil	Fundición Dúctil	Fundición Dúctil
31	Tuerca guía husillo	Bronce-Aluminio	Bronce-Aluminio	Bronce-Aluminio
70	Husillo	Monel®	Monel®	Monel®
52	Tornillo ojo	Acero carbono	Acero carbono	Acero carbono
16a	Tuerca	Acero carbono	Acero carbono	Acero carbono
36	Brida prensaestopas	Acero carbono	Acero carbono	Acero carbono
35	Prensaestopas	Monel®	Monel®	Monel®
49	Pasador	Acero carbono	Acero carbono	Acero carbono
30	Tapa	ASTM A216 Gr. WCB	ASTM A494 Gr. M35-1	ASTM A494 Gr. M35-1
33	Linterna	Monel®	Monel®	Monel®
150	Inyector grasa	Acero carbono y Monel®	Acero carbono y Monel®	Acero carbono y Monel®
46	Empaquetadura	Grafito	Grafito	Grafito
55	Junta cuerpo-tapa	Anillo Acero dulce	Anillo Monel®	Anillo Monel®
32	Casquillo husillo	Monel®	Monel®	Monel®
72	Tuerca obturador	Monel®	Monel®	Monel®
10	Cuerpo	ASTM A216 Gr. WCB	ASTM A494 Gr. M35-1	ASTM A494 Gr. M35-1
11	Asiento	Monel®	Monel®	Monel®
113	Pletina empuje	Monel®	Monel®	Monel®
71	Obturador	Monel®	Monel®	Monel®
98	Espárrago	ASTM A193 Gr. B7M	ASTM A193 Gr. B7M	ASTM A193 Gr. B7M
16b	Tuerca	ASTM A194 Gr. 2HM	ASTM A194 Gr. 2HM	ASTM A194 Gr. 2HM
85	Arandela volante	12% Cromo	12% Cromo	12% Cromo

FIG. 366-HF8 (-M35-1) - GLOBO ALQUILACIÓN 300LBS BRIDAS UOP

DIM.	DESCRIPCIÓN	TAMAÑO VÁLVULA							
		1.1/2"	2"	2.1/2"	3"	4"	6"	8"	
A ₁	Distancia entre caras RF	226	267	292	318	356	445	559	
A ₂	Distancia entre caras RTJ	241	283	308	333	371	460	575	
J	Dist. centro al inyector	132	140	149	155	178	194	229	
K	Abierta	397	362	394	429	477	601	718	
L	Cerrada	365	343	372	404	445	556	661	
M	Diám. volante	203	203	203	203	356	457	457	
	Peso (kg.)	27	29	48	56	80	165	271	

RETENCIÓN PISTÓN ALQUILACIÓN 800LBS UOP 1/2" - 2"

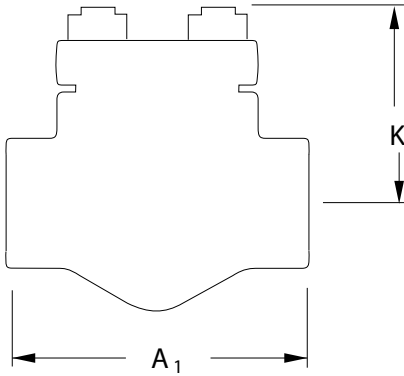

CRANE® PACIFIC Retención Fig. 3682-HF8 (-M35-1)		Diseño: API 602
VÁLVULA RETENCIÓN A PISTÓN PARA SERVICIOS DE ALQUILACIÓN		
Especificaciones		
Material cuerpo	ASTM A216 Gr. WCB / A105 o ASTM A194 Gr. M35-1	
Obturador	Monel®	
Conexiones	Bridas, Roscadas o Socket Weld	
Rating	800LBS	
Fire Safe	Según API 607 (última edición)	
Presión prueba	Cuerpo: 3000 psig Asiento: 2200 psig Cuerpo (helio): 500 psig	
Aplicaciones	Fundamentalmente en la industria Petroquímica	

Pos.	Denominación	Componentes	
		Material	
		Fig. 3682-HF8	Fig. 3682-HF8 (-M35-1)
98	Espárrago	ASTM A193 Gr. B7M	ASTM A193 Gr. B7M
16	Tuerca	ASTM A194 Gr. 2HM	ASTM A193 Gr. 2HM
30	Tapa	ASTM A216 Gr. WCB o A515 Gr. 70	ASTM A494 Gr. M35-1
55	Junta cuerpo-tapa	Espirometálica Monel® / Grafito	Espirometálica Monel® / Grafito
71	Obturador	Monel®	Monel®
10	Cuerpo	ASTM A105 o ASTM A216 Gr. WCB	ASTM A494 Gr. M35-1
11	Asiento	Monel®	Monel®

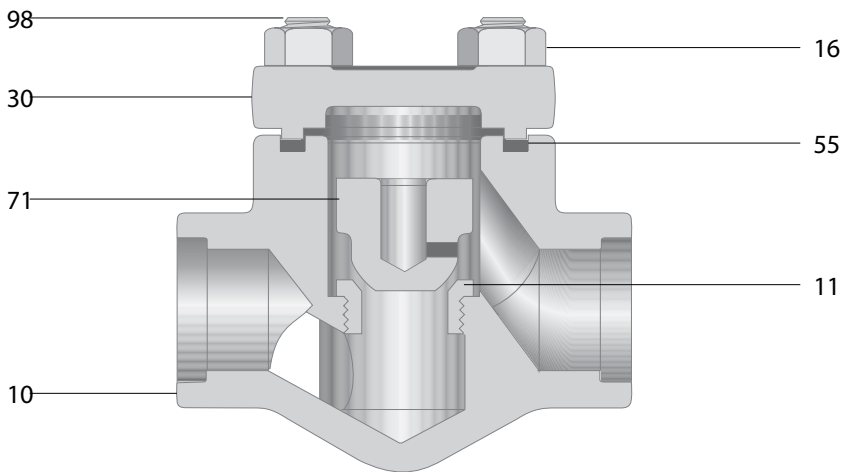

FIG. 3682-HF8 (-M35-1) - RETENCIÓN A PISTÓN ALQUILACIÓN 800LBS SW UOP

DIM.	DESCRIPCIÓN	TAMAÑO VÁLVULA				
		1/2"	3/4"	1"	1.1/2"	2"
A ₁	Distancia entre caras SW	92	114	130	178	213
K	Altura desde el centro	64	76	87	127	140
X	Profundidad paso SW	10	13	13	13	16
Y	Diámetro paso SW	22	27	34	49	61
	Peso (kg.)	1,4	2,7	4,1	9,1	15,9

VÁLVULAS PARA ALQUILACIÓN

RETENCIÓN PISTÓN ALQUILACIÓN 600LBS UOP 1/2" - 1"

CRANE® PACIFIC Retención Fig. 3680-HF8 (-M35-1)		Diseño: API 600
VÁLVULA RETENCIÓN A PISTÓN PARA SERVICIOS DE ALQUILACIÓN		
Especificaciones		
Material cuerpo	ASTM A494 Gr. M35-1	
Obturador	Monel®	
Conexiones	Bridas, Roscadas o Socket Weld	
Rating	600LBS	
Fire Safe	Según API 607 (última edición)	
Presión prueba	Cuerpo: 3000 psig Asiento: 2200 psig Cuerpo (helio): 500 psig	
Aplicaciones	Fundamentalmente en la industria Petroquímica	

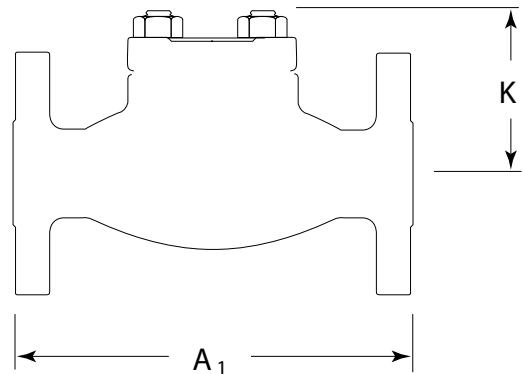

Componentes		
Pos.	Denominación	Material
98	Espárrago	ASTM A193 Gr. B7M
16	Tuerca	ASTM A194 Gr. 2HM
30	Tapa	ASTM A494 Gr. M35-1
55	Junta cuerpo-tapa	Anillo Monel®
71	Obturador	Monel®
10	Cuerpo	ASTM A494 Gr. M35-1
11	Asiento	Monel®

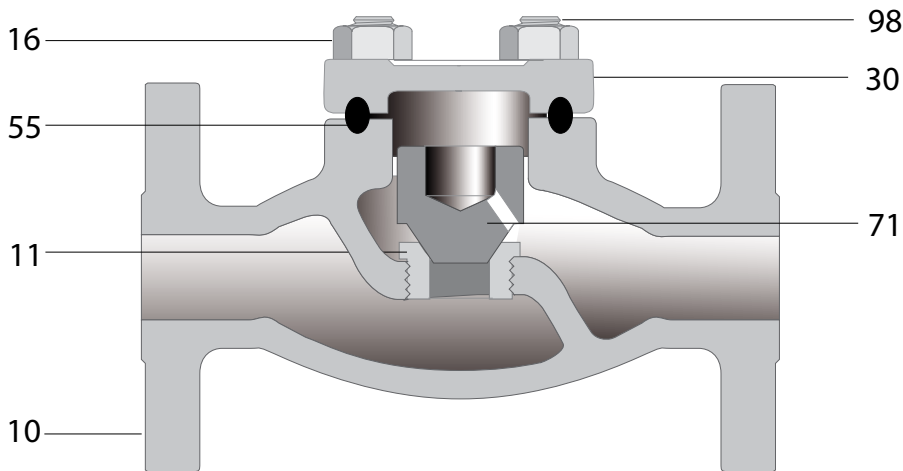
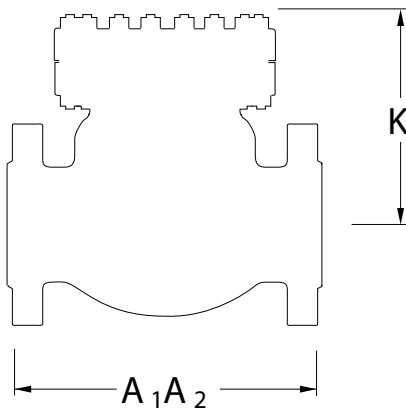

FIG. 3680-HF8 (-M35-1) - RETENCIÓN A PISTÓN ALQUILACIÓN 600LBS BRIDAS UOP

DIM.	DESCRIPCIÓN	TAMAÑO VÁLVULA		
		1/2"	3/4"	1"
A ₁	Distancia entre caras RF	165	191	216
K	Altura desde el centro	66	80	90
	Peso (kg.)	3,6	6,4	8,6

RETENCIÓN CLAPETA ALQUILACIÓN 150LBS UOP 1.1/2" - 30"



CRANE® PACIFIC Retención Fig. 180-HF8		Diseño: API 600
VÁLVULA RETENCIÓN A CLAPETA PARA SERVICIOS DE ALQUILACIÓN		
Especificaciones		
Material cuerpo	Acero carbono ASTM A216 Gr. WCB	
Obturador	Monel®	
Conexiones	Bridas, Roscadas o Socket Weld	
Rating	150LBS	
Fire Safe	Según API 607 (última edición)	
Presión prueba	Cuerpo: 450 psig Asiento: 320 psig Cuerpo (helio): 450 psig	
Aplicaciones	Fundamentalmente en la industria Petroquímica	

Componentes		
Pos.	Denominación	Material
98	Espárrago	ASTM A193 Gr. B7M
16	Tuerca	ASTM A194 Gr. 2HM
55	Junta cuerpo-tapa	Corrugada Acero dulce / PTFE
30	Tapa	ASTM A216 Gr. WCB o A515 Gr. 70
40	Biela	Monel®
41	Bulón	Monel®
10	Cuerpo	ASTM A216 Gr. WCB
11	Asiento	Monel®
49	Pasador	Monel®
71	Obturador	Monel®
85	Arandela	Monel®
72	Tuerca	Monel®

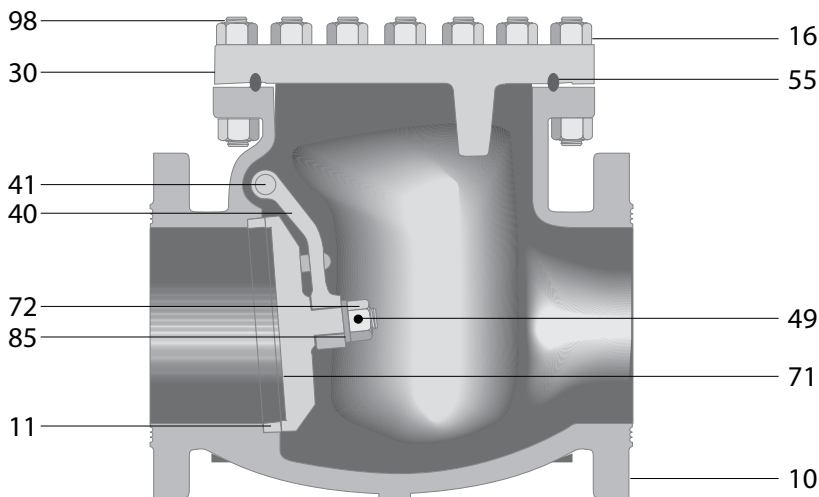

DIM.	DESCRIPCIÓN	TAMAÑO VÁLVULA														
		1.1/2"	2"	2.1/2"	3"	4"	6"	8"	10"	12"	14"	16"	18"	20"	24"	30"
A ₁	Distancia entre caras RF	165	203	216	241	292	356	495	622	699	787	864	978	978	1295	1524
A ₂	Distancia entre caras RTJ	178	216	229	254	305	368	508	635	711	800	876	991	991	1308	1550
K	Altura desde el centro	98	137	152	165	191	235	286	302	346	403	536	565	629	864	997
	Peso (kg.)	12	18	23	29	47	82	152	235	319	408	533	679	1075	2077	2667

VÁLVULAS PARA ALQUILACIÓN

RETENCIÓN CLAPETA ALQUILACIÓN 300LBS UOP 1.1/2" - 30"

CRANE® PACIFIC Retención Fig. 380-HF8		Diseño: API 600
VÁLVULA RETENCIÓN A CLAPETA PARA SERVICIOS DE ALQUILACIÓN		
Especificaciones		
Material cuerpo	Acero carbono ASTM A216 Gr. WCB	
Obturador	Monel®	
Conexiones	Bridas, Roscadas o Socket Weld	
Rating	300LBS	
Fire Safe	Según API 607 (última edición)	
Presión prueba	Cuerpo: 1125 psig Asiento: 825 psig Cuerpo (helio): 500 psig	
Aplicaciones	Fundamentalmente en la industria Petroquímica	

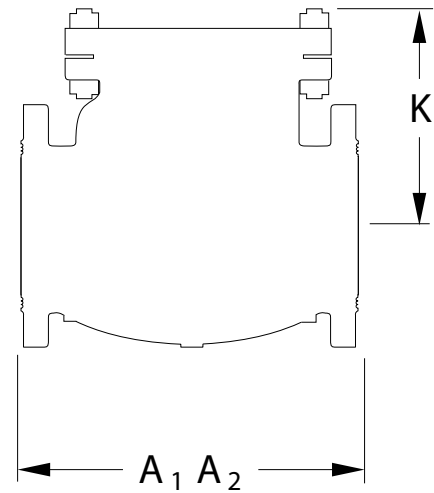

Componentes		
Pos.	Denominación	Material
98	Espárrago	ASTM A193 Gr. B7M
16	Tuerca	ASTM A194 Gr. 2HM
30	Tapa	ASTM A216 Gr. WCB o A515 Gr. 70
55	Junta cuerpo-tapa	Corrugada Acero dulce / PTFE
41	Bulón	Monel®
10	Cuerpo	Monel®
72	Tuerca	ASTM A216 Gr. WCB
85	Arandela	Monel®
71	Obturador	Monel®
49	Pasador	Monel®
11	Recubrimiento asiento	Monel®

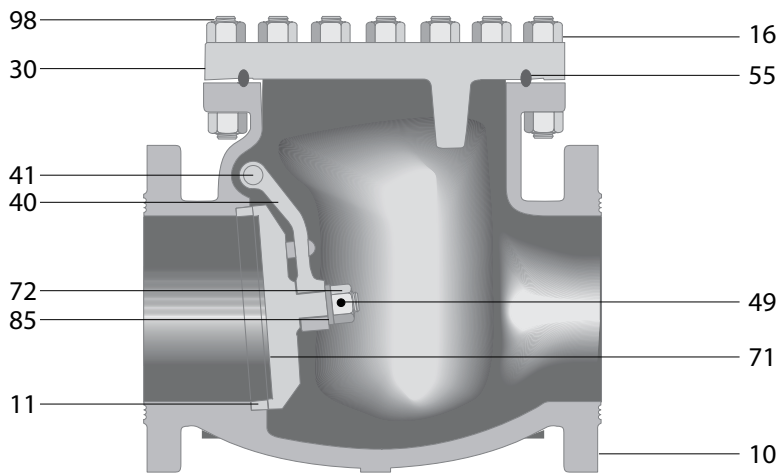
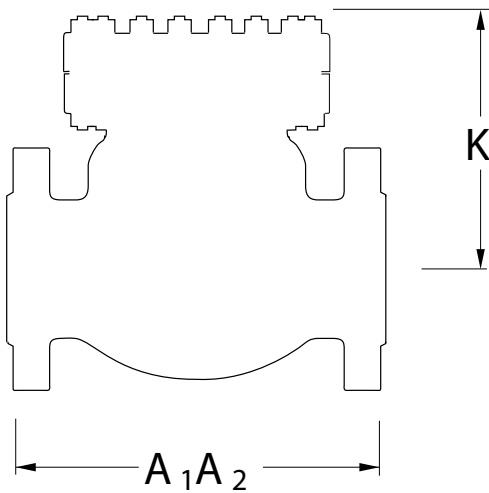

FIG. 380-HF8 - RETENCIÓN A CLAPETA ALQUILACIÓN 300LBS BRIDAS UOP

DIM.	DESCRIPCIÓN	TAMAÑO VÁLVULA														
		1.1/2"	2"	2.1/2"	3"	4"	6"	8"	10"	12"	14"	16"	18"	20"	24"	30"
A ₁	Distancia entre caras RF	241	267	292	318	356	445	533	622	711	838	864	978	1015	1346	1594
A ₂	Distancia entre caras RTJ	254	283	309	334	372	461	550	639	728	855	880	994	1036	1369	1619
K	Altura desde el centro	163	185	204	223	248	305	337	407	458	528	588	626	709	801	997
	Peso (kg.)	23	25	36	54	84	135	207	353	536	794	893	1101	1505	2580	2994

RETENCIÓN CLAPETA ALQUILACIÓN 300LBS UOP 1.1/2" - 30"



CRANE® PACIFIC Retención Fig. 380R-HF8		Diseño: API 600
VÁLVULA RETENCIÓN A CLAPETA PARA SERVICIOS DE ALQUILACIÓN		
Especificaciones		
Material cuerpo	Acero carbono ASTM A216 Gr. WCB	
Obturador	Monel®	
Conexiones	Bridas, Roscadas o Socket Weld	
Rating	300LBS	
Fire Safe	Según API 607 (última edición)	
Presión prueba	Cuerpo: 1125 psig Asiento: 825 psig Cuerpo (helio): 450 psig	
Aplicaciones	Fundamentalmente en la industria Petroquímica	

Componentes		
Pos.	Denominación	Material
98	Espárrago	ASTM A193 Gr. B7M
16	Tuerca	ASTM A194 Gr. 2HM
30	Tapa	ASTM A216 Gr. WCB o A515 Gr. 70
55	Junta cuerpo-tapa	Anillo Acero dulce
40	Biela	Monel®
41	Bulón	Monel®
10	Cuerpo	ASTM A216 Gr. WCB
72	Tuerca obturador	Monel®
85	Arandela	Monel®
71	Obturador	Monel®
49	Pasador	Monel®
11	Recubrimiento asiento	Monel®

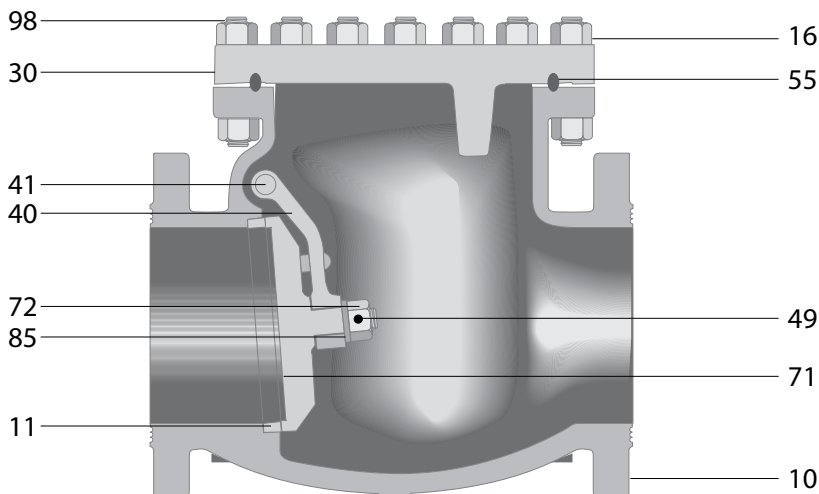

FIG. 380R-HF8 - RETENCIÓN A CLAPETA ALQUILACIÓN 300LBS BRIDAS UOP

DIM.	DESCRIPCIÓN	TAMAÑO VÁLVULA														
		1.1/2"	2"	2.1/2"	3"	4"	6"	8"	10"	12"	14"	16"	18"	20"	24"	30"
A ₁	Distancia entre caras RF	241	267	292	318	356	445	533	622	711	838	864	978	1015	1346	1594
A ₂	Distancia entre caras RTJ	254	283	309	334	372	461	550	639	728	855	880	994	1036	1369	1619
K	Altura desde el centro	163	178	187	203	225	289	337	387	458	489	530	565	581	845	997
	Peso (kg.)	23	29	39	50	73	150	231	356	581	676	922	1110	1352	2195	2994

VÁLVULAS PARA ALQUILACIÓN

COMPUERTA ALQUILACIÓN 300LBS PHILLIPS 1/2" - 2"

CRANE® PACIFIC Compuerta Fig. 3554P-HF8 (-M35-1)		Diseño: API 600
VÁLVULA COMPUERTA PARA SERVICIOS DE ALQUILACIÓN		
Especificaciones		
Material cuerpo	ASTM A216 Gr. WCB o ASTM A494 Gr. M35-1	
Asientos	Monel® 400	
Conexiones	Bridas, Roscadas o Socket Weld	
Rating	300LBS	
Pruebas	API 598 y API 622 "Packing Emission" para válvulas de proceso	
Fire Safe	Según API 607 (última edición)	
Presión prueba	Fig. 3354P-HF8 Cuerpo: 1125 psig Asiento: 825 psig Cuerpo (helio): 500 psig	Fig. 3354P-HF8 (-M35-1) Cuerpo: 1100 psig Asiento: 800 psig Cuerpo (helio): 500 psig
Aplicaciones	Fundamentalmente en la industria Petroquímica	

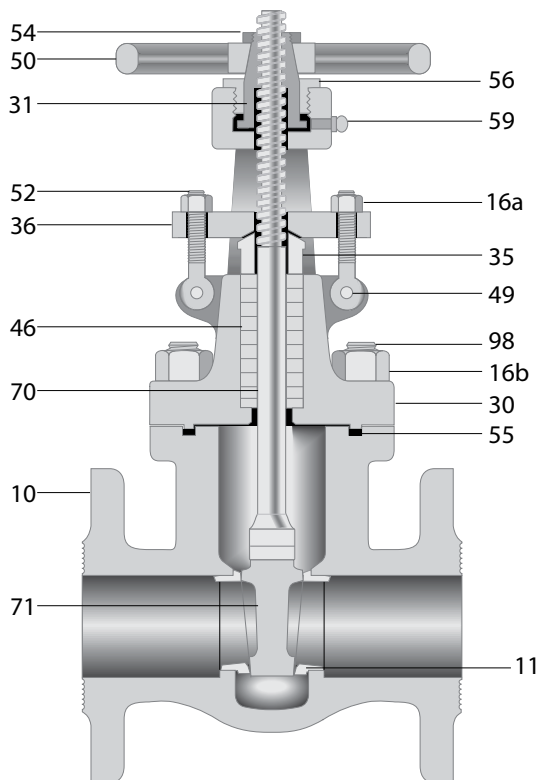
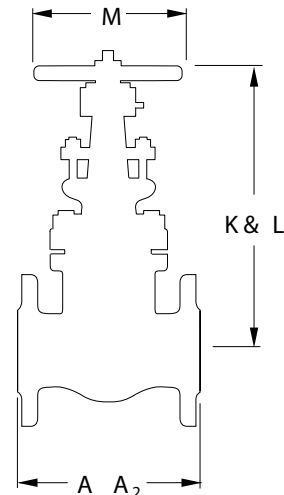

Pos.	Denominación	Componentes	
		Fig. 3354P-HF8	Fig. 3354P-HF8 (-M35-1)
10	Cuerpo	ASTM A216 Gr. WCB o ASTM A105	ASTM A494 Gr. M35-1
11	Asiento	Monel® 400	Monel® 400
16a	Tuerca	Acero carbono	Acero carbono
16b	Tuerca	ASTM A194 Gr. 2HM	ASTM A194 Gr. 2HM
30	Tapa	ASTM A216 Gr. WCB o ASTM A105	ASTM A494 Gr. M35-1
31	Tuerca guía husillo	12% Cromo	12% Cromo
35	Prensaestopas	Monel® 400	Monel® 400
36	Brida prensaestopas	Acero carbono	Acero carbono
46	Empaquetadura	PTFE	PTFE
49	Pasador	Acero carbono	Acero carbono
50	Volante	Hierro maleable	Hierro maleable
52	Tornillo ojo	Acero carbono	Acero carbono
54	Tuerca volante	Acero carbono	Acero carbono
55	Junta cuerpo-tapa	Espirometálica Monel® / PTFE	Espirometálica Monel® / PTFE
56	Contratuerca	Acero carbono	Acero carbono
59	Accesorio engrasador	Acero carbono	Acero carbono
70	Husillo	K-Monel®	K-Monel®
71	Cuña	Monel® 400	Monel® 400
98	Espárrago	ASTM A193 Gr. B7M	ASTM A193 Gr. B7M

FIG. 3354P-HF8 (-M35-1) - COMPUERTA ALQUILACIÓN 300LBS RF PHILLIPS

DIM.	DESCRIPCIÓN	TAMAÑO VÁLVULA				
		1/2"	3/4"	1"	1.1/2"	2"
A ₁	Distancia entre caras	140	152	165	191	216
K	Abierta	241	267	298	375	410
L	Cerrada	222	245	270	330	400
M	Diám. volante	89	114	114	140	203
	Peso (kg.)	5,4	7,7	10	17,2	24,9

COMPUERTA ALQUILACIÓN 600LBS PHILLIPS 1/2" - 2"

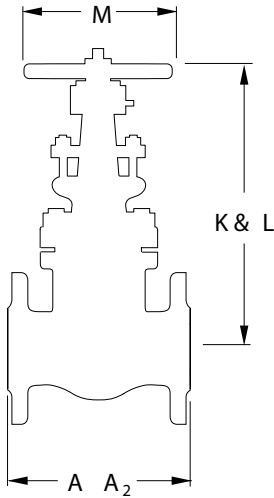

CRANE® PACIFIC Compuerta Fig. 3654P-HF8 (-M35-1)		Diseño: API 600
VÁLVULA COMPUERTA PARA SERVICIOS DE ALQUILACIÓN		
Especificaciones		
Material cuerpo	ASTM A216 Gr. WCB o A105 o ASTM A494 Gr. M35-1	
Asientos	Monel® 400	
Conexiones	Bridas, Roscadas o Socket Weld	
Rating	600LBS	
Pruebas	API 598 y API 622 "Packing Emission" para válvulas de proceso	
Fire Safe	Según API 607 (última edición)	
Presión prueba	Cuerpo: 2250 psig Asiento: 1650 psig Cuerpo (helio): 500 psig	
Aplicaciones	Fundamentalmente en la industria Petroquímica	

Pos.	Denominación	Componentes	
		Fig. 3354P-HF8	Fig. 3354P-HF8 (-M35-1)
10	Cuerpo	ASTM A216 Gr. WCB o ASTM A105	ASTM A494 Gr. M35-1
11	Asiento	Monel® 400	Monel® 400
16a	Tuerca	Acero carbono	Acero carbono
16b	Tuerca	ASTM A194 Gr. 2HM	ASTM A194 Gr. 2HM
30	Tapa	ASTM A216 Gr. WCB o ASTM A105	ASTM A494 Gr. M35-1
31	Tuerca guía husillo	12% Cromo	12% Cromo
35	Prensaestopas	Monel® 400	Monel® 400
36	Brida prensaestopas	Acero carbono	Acero carbono
46	Empaquetadura	PTFE	PTFE
49	Pasador	Acero carbono	Acero carbono
50	Volante	Hierro maleable	Hierro maleable
52	Tornillo ojo	Acero carbono	Acero carbono
54	Tuerca volante	Acero carbono	Acero carbono
55	Junta cuerpo-tapa	Espirometálica Monel® / PTFE	Espirometálica Monel® / PTFE
56	Contratuerca	Acero carbono	Acero carbono
59	Accesorio engrasador	Acero carbono	Acero carbono
70	Husillo	K-Monel®	K-Monel®
71	Cuña	Monel® 400	Monel® 400
98	Espárrago	ASTM A193 Gr. B7M	ASTM A193 Gr. B7M

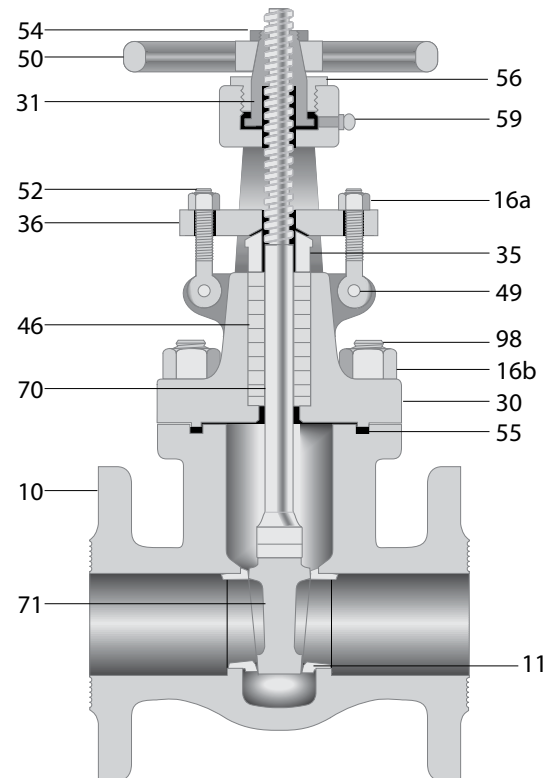

FIG. 3654P-HF8 (-M35-1) - COMPUERTA ALQUILACIÓN 600LBS RF PHILLIPS

DIM.	DESCRIPCIÓN	TAMAÑO VÁLVULA				
		1/2"	3/4"	1"	1.1/2"	2"
A ₁	Distancia entre caras	164	191	216	241	292
K	Abierta	229	254	280	362	439
L	Cerrada	207	229	247	316	381
M	Diám. volante	89	114	114	140	203
	Peso (kg.)	5,9	8,2	10,9	19,1	29,0

VÁLVULAS PARA ALQUILACIÓN

COMPUERTA ALQUILACIÓN 800LBS PHILLIPS 1/2" - 2"

CRANE® PACIFIC Compuerta Fig. 3665P-HF8 (-M35-1)		Diseño: API 602
VÁLVULA COMPUERTA PARA SERVICIOS DE ALQUILACIÓN		
Especificaciones		
Material cuerpo	ASTM A494 Gr. M35-1	
Asientos	Monel® 400	
Conexiones	Bridas, Roscadas o Socket Weld	
Rating	800LBS	
Pruebas	API 598 y API 622 "Packing Emission" para válvulas de proceso	
Fire Safe	Según API 607 (última edición)	
Presión prueba	Fig. 3665P-HF8 Cuerpo: 3000 psig Asiento: 2200 psig Cuerpo (helio): 500 psig	Fig. 3665P-HF8 (-M35-1) Cuerpo: 3000 psig Asiento: 2200 psig Cuerpo (helio): 500 psig
Aplicaciones	Fundamentalmente en la industria Petroquímica	

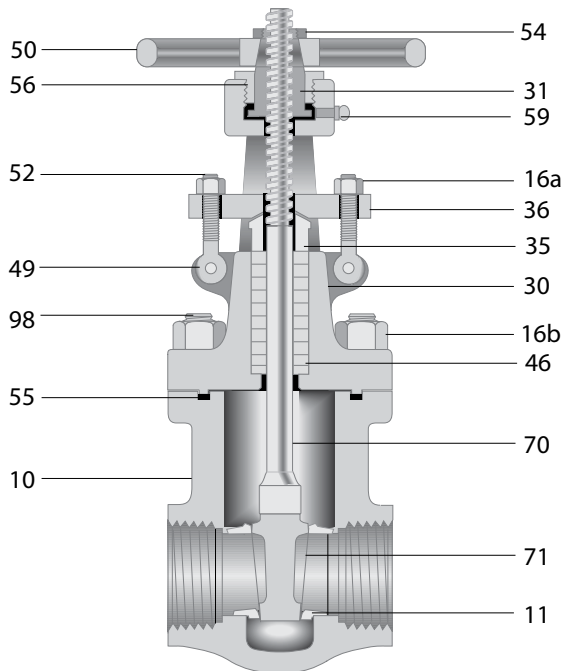
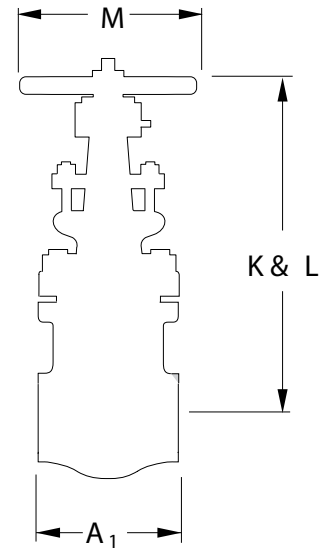

Componentes		
Pos.	Denominación	Material
10	Cuerpo	ASTM A494 Gr. M35-1
11	Asiento	Monel® 400
16a	Tuerca	Acero carbono
16b	Tuerca	ASTM A194 Gr. 2HM
30	Tapa	ASTM A494 Gr. M35-1
31	Tuerca guía husillo	12% Cromo
35	Prensaestopas	Monel® 400
36	Brida prensaestopas	Acero carbono
46	Empaquetadura	PTFE
49	Pasador	Acero carbono
50	Volante	Hierro maleable
52	Tornillo ojo	Acero carbono
54	Tuerca volante	Acero carbono
55	Junta cuerpo-tapa	Espirometálica Monel® / PTFE
56	Contratuerca	Acero carbono
59	Accesorio engrasador	Acero carbono
70	Husillo	K-Monel®
71	Cuña	Monel® 400
98	Espárrago	ASTM A193 Gr. B7M

FIG. 3665P-HF8 (-M35-1) - COMPUERTA ALQUILACIÓN 800LBS NPT PHILLIPS

DIM.	DESCRIPCIÓN	TAMAÑO VÁLVULA				
		1/2"	3/4"	1"	1.1/2"	2"
A ₁	Distancia entre caras	76	89	105	121	133
K	Abierta	229	254	280	362	439
L	Cerrada	207	229	247	316	381
M	Diám. volante	102	108	108	140	203
	Peso (kg.)	3,2	4,1	6,4	10,9	17,7

COMPUERTA ALQUILACIÓN 800LBS PHILLIPS 1/2" - 2"

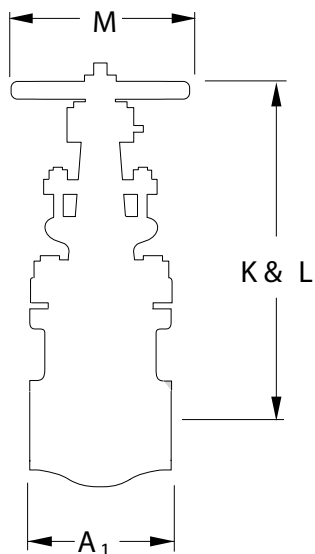

CRANE® PACIFIC Compuerta Fig. 3665P-HF8		Diseño: API 602
VÁLVULA COMPUERTA PARA SERVICIOS DE ALQUILACIÓN		
Especificaciones		
Material cuerpo	ASTM A216 Gr. WCB o ASTM A105	
Asientos	Monel® 400	
Conexiones	Bridas, Roscadas o Socket Weld	
Rating	800LBS	
Pruebas	API 598 y API 622 "Packing Emission" para válvulas de proceso	
Fire Safe	Según API 607 (última edición)	
Presión prueba	Fig. 3665P-HF8 Cuerpo: 3000 psig Asiento: 2200 psig Cuerpo (helio): 500 psig	Fig. 3665P-HF8 (-M35-1) Cuerpo: 3000 psig Asiento: 2200 psig Cuerpo (helio): 500 psig
Aplicaciones	Fundamentalmente en la industria Petroquímica	

Componentes		
Pos.	Denominación	Material
10	Cuerpo	ASTM A216 Gr. WCB o ASTM A105
11	Asiento	Monel® 400
16a	Tuerca	Acero carbono
16b	Tuerca	ASTM A194 Gr. 2HM
30	Tapa	ASTM A216 Gr. WCB o ASTM A105
31	Tuerca guía husillo	12% Cromo
35	Prensaestopas	Monel® 400
36	Brida prensaestopas	Acero carbono
46	Empaquetadura	PTFE
49	Pasador	Acero carbono
50	Volante	Hierro maleable
52	Tornillo ojo	Acero carbono
54	Tuerca volante	Acero carbono
55	Junta cuerpo-tapa	Espirometálica Monel® / PTFE
56	Contratuercas	Acero carbono
59	Accesorio engrasador	Acero carbono
70	Husillo	K-Monel®
71	Cuña	Monel® 400
98	Espárrago	ASTM A193 Gr. B7M

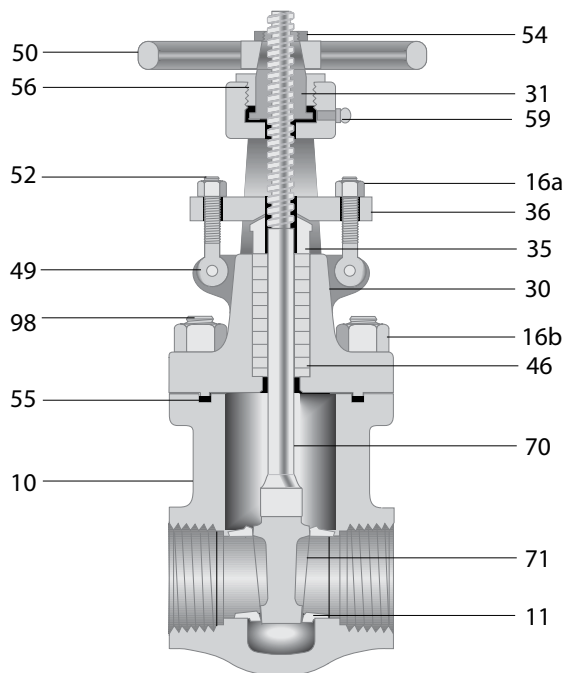

FIG. 3655P-HF8 - COMPUERTA ALQUILACIÓN 800LBS NPT PHILLIPS

DIM.	DESCRIPCIÓN	TAMAÑO VÁLVULA				
		1/2"	3/4"	1"	1.1/2"	2"
A ₁	Distancia entre caras	76	89	105	121	133
K	Abierta	229	254	280	362	439
L	Cerrada	207	229	247	316	381
M	Diám. volante	102	108	108	140	203
	Peso (kg.)	3,2	4,1	6,4	10,9	17,7

VÁLVULAS PARA ALQUILACIÓN

COMPUERTA ALQUILACIÓN 300LBS PHILLIPS 1.1/2" - 36"

CRANE® PACIFIC Compuerta Fig. 350P-HF8 (-M35-1)		Diseño: API 600
VÁLVULA COMPUERTA PARA SERVICIOS DE ALQUILACIÓN		
Especificaciones		
Material cuerpo	ASTM A216 Gr. WCB o ASTM A494 Gr. M35-1	
Asientos	Monel® 400	
Conexiones	Bridas, Roscadas o Socket Weld	
Rating	300LBS	
Pruebas	API 598 y API 622 "Packing Emission" para válvulas de proceso	
Fire Safe	Según API 607 (última edición)	
Presión prueba	Fig. 350P-HF8 Cuerpo: 1125 psig Asiento: 825 psig Cuerpo (helio): 500 psig	Fig. 350P-HF8 (-M35-1) Cuerpo: 1100 psig Asiento: 800 psig Cuerpo (helio): 500 psig
Aplicaciones	Fundamentalmente en la industria Petroquímica	

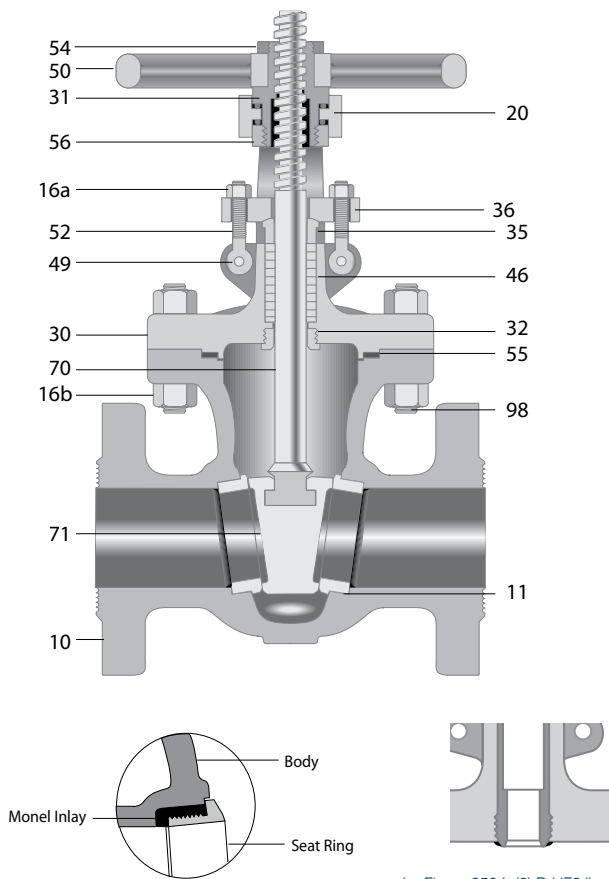
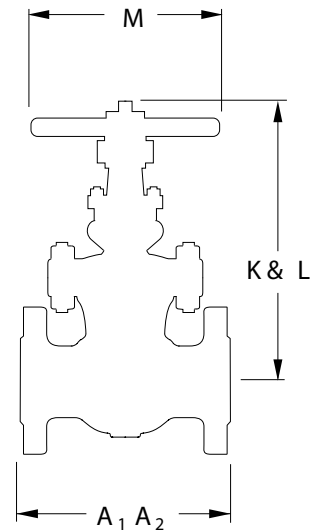

Pos.	Denominación	Componentes	
		Fig. 350P-HF8	Fig. 350P-HF8-M35-1
		Material	
10	Cuerpo	ASTM A216 Gr. WCB	ASTM A494 Gr. M35-1
11	Asiento	Monel® 400	Monel® 400
16b	Tuerca	ASTM A194 Gr. 2HM	ASTM A194 Gr. 2HM
16a	Tuerca	Acero carbono	Acero carbono
20	Cojinetes	Acero aleado	Acero aleado
30	Tapa	ASTM A216 Gr. WCB	ASTM A494 Gr. M35-1
31	Tuerca guía husillo	Bronce-Aluminio o 12% Cromo	Bronce-Aluminio o 12% Cromo
32	Casquillo husillo	Monel® 400	Monel® 400
35	Prensaestopas	Monel® 400	Monel® 400
36	Brida prensaestopas	Acero carbono	Acero carbono
46	Empaquetadura	John Crane 124	John Crane 124
49	Pasador	Acero carbono	Acero carbono
50	Volante	Hierro maleable	Hierro maleable
52	Tornillo ojo	Acero carbono	Acero carbono
54	Tuerca volante	Acero carbono	Acero carbono
55	Junta cuerpo-tapa	Espirometálica Monel® / PTFE	Espirometálica Monel® / PTFE
56	Contratuerca	Acero carbono	Acero carbono
70	Husillo	Monel®	Monel®
71	Cuña	Monel® 400	Monel® 400
98	Espárrago	ASTM A193 Gr. B7M	ASTM A193 Gr. B7M

La Figura 350 L (2) P-HF8 lleva camisa de Monel® que cubre la caja prensaestopas

La Figura 350PX-HF8 incluye asientos roscados con todas las piezas en Monel®

FIG. 350P-HF8 (-M35-1) - COMPUERTA ALQUILACIÓN 300LBS BRIDAS PHILLIPS

DIM.	DESCRIPCIÓN	TAMAÑO VÁLVULA															
		1.1/2"	2"	2.1/2"	3"	4"	6"	8"	10"	12"	14"	16"	18"	20"	24"	30"	36"
A ₁	Distancia entre caras RF	191	216	241	283	305	403	419	457	502	762	838	914	991	1143	1397	1727
A ₂	Distancia entre caras RTJ	203	232	257	299	321	419	435	473	518	778	854	930	1007	1165	1422	1756
K	Abierta	442	451	491	491	715	918	1115	1297	1468	1684	1835	2008	2245	2602	3505	3962
L	Cerrada	386	391	408	408	595	743	883	1022	1141	1324	1432	1557	1740	1988	2743	3073
M	Diámetro volante	254	254	254	254	356	457	610	610	610	610	711	711	711	864	864	864
	Peso (kg.)	30	32	57	61	98	175	297	453	597	868	1182	1504	1938	3411	4907	6940

COMPUERTA ALQUILACIÓN 300LBS PHILLIPS 1.1/2" - 36"

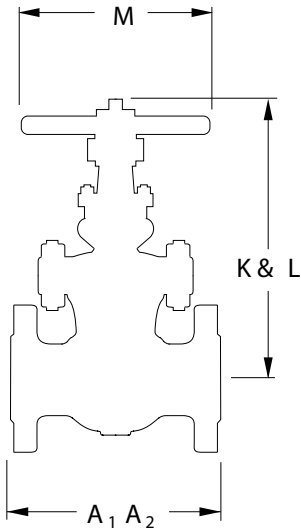

CRANE® PACIFIC Compuerta Fig. 350P-HF8-BTT (-M35-1)		Diseño: API 600
VÁLVULA COMPUERTA PARA SERVICIOS DE ALQUILACIÓN		
Especificaciones		
Material cuerpo	ASTM A216 Gr. WCB o ASTM A494 Gr. M35-1	
Asientos	Monel® 400	
Conexiones	Bridas, Roscadas o Socket Weld	
Rating	300LBS	
Pruebas	API 598 y API 622 "Packing Emission" para válvulas de proceso	
Fire Safe	Según API 607 (última edición)	
Presión prueba	Fig. 350P-HF8 Cuerpo: 1125 psig Asiento: 825 psig Cuerpo (helio): 500 psig	Fig. 350P-HF8 (-M35-1) Cuerpo: 1100 psig Asiento: 800 psig Cuerpo (helio): 500 psig
Aplicaciones	Fundamentalmente en la industria Petroquímica	

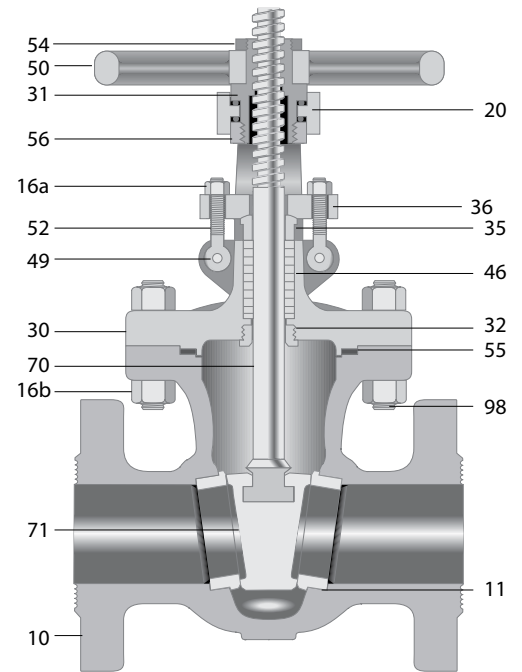
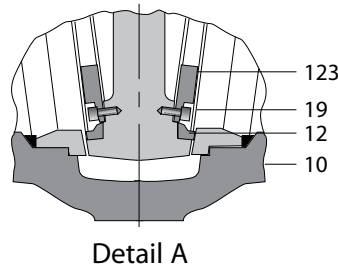

Pos.	Denominación	Componentes	
		Fig. 350P-HF8-BTT	Fig. 350P-HF8-BTT-M35-1
10	Cuerpo	ASTM A216 Gr. WCB	ASTM A494 Gr. M35-1
11	Asiento	Monel® 400	Monel® 400
16b	Tuerca	ASTM A194 Gr. 2HM	ASTM A194 Gr. 2HM
16a	Tuerca	Acero carbono	Acero carbono
20	Cojinetes	Acero aleado	Acero aleado
30	Tapa	ASTM A216 Gr. WCB	ASTM A494 Gr. M35-1
31	Tuerca guía husillo	Bronce-Aluminio o 12% Cromo	Bronce-Aluminio o 12% Cromo
32	Casquillo husillo	Monel® 400	Monel® 400
35	Prensaestopas	Monel® 400	Monel® 400
36	Brida prensaestopas	Acero carbono	Acero carbono
46	Empaquetadura	John Crane 124	John Crane 124
49	Pasador	Acero carbono	Acero carbono
50	Volante	Hierro maleable	Hierro maleable
52	Tornillo ojo	Acero carbono	Acero carbono
54	Tuerca volante	Acero carbono	Acero carbono
55	Junta cuerpo-tapa	Espirometálica Monel® / PTFE	Espirometálica Monel® / PTFE
56	Contratuerca	Acero carbono	Acero carbono
70	Husillo	Monel®	Monel®
71	Cuña	Monel® 400	Monel® 400
98	Espárrago	ASTM A193 Gr. B7M	ASTM A193 Gr. B7M
123	Anillo compresión	Monel®	
19	Tornillo	K-Monel® 500	
12	Inserto	PTFE	

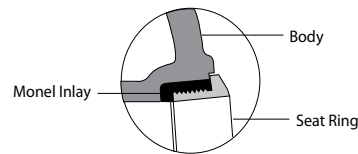

La Figura 350P-HF8 incluye asientos roscados con todas las piezas en Monel



La Figura 350 L (2) P-HF8 lleva camisa de Monel® que cubre la caja prensaestopas

FIG. 350P-HF8-BTT (-M35-1) - COMPUERTA ALQUILACIÓN 300LBS BRIDAS PHILLIPS

DIM.	DESCRIPCIÓN	TAMAÑO VÁLVULA															
		1.1/2"	2"	2.1/2"	3"	4"	6"	8"	10"	12"	14"	16"	18"	20"	24"	30"	36"
A ₁	Distancia entre caras RF	191	216	241	283	305	403	419	457	502	762	838	914	991	1143	1397	1727
A ₂	Distancia entre caras RTJ	203	232	257	299	321	419	435	473	518	778	854	930	1007	1165	1422	1756
K	Abierta	442	451	491	491	715	918	1115	1297	1468	1684	1835	2008	2245	2602	3505	3962
L	Cerrada	386	391	408	408	595	743	883	1022	1141	1324	1432	1557	1740	1988	2743	3073
M	Diámetro volante	254	254	254	254	356	457	610	610	610	610	711	711	711	864	864	864
	Peso (kg.)	30	32	57	61	98	175	297	453	597	868	1182	1504	1938	3411	4907	6940

VÁLVULAS PARA ALQUILACIÓN

GLOBO ALQUILACIÓN 300LBS PHILLIPS 1/2" - 2"

CRANE® PACIFIC Globo Fig. 3367-HF8		Diseño: API 600
VÁLVULA GLOBO PARA SERVICIOS DE ALQUILACIÓN		
Especificaciones		
Material cuerpo	Acero carbono ASTM A216 Gr. WCB	
Obturador	Monel® 400	
Conexiones	Bridas, Roscadas o Socket Weld	
Rating	300LBS	
Pruebas	API 598 y API 622 "Packing Emission" para válvulas de proceso	
Fire Safe	Según API 607 (última edición)	
Presión prueba	Cuerpo: 1125 psig Asiento: 825 psig Cuerpo (helio): 500 psig	
Aplicaciones	Fundamentalmente en la industria Petroquímica	

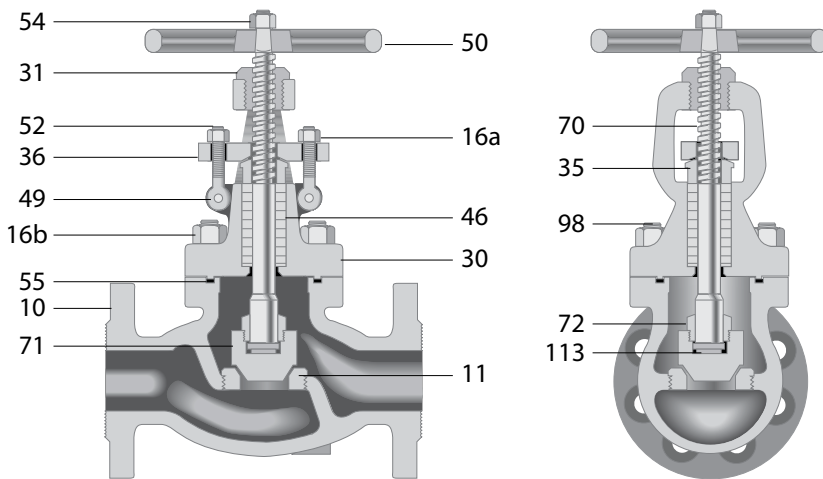
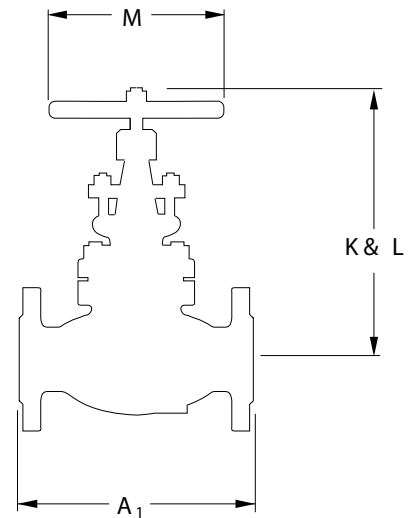

Componentes		
Pos.	Denominación	Material
10	Cuerpo	ASTM A216 Gr. WCB
11	Asiento	Monel® 400
16a	Tuerca	Acero carbono
16b	Tuerca	ASTM A194 Gr. 2HM
30	Tapa	ASTM A216 Gr. WCB
31	Tuerca guía husillo	12% Cromo
35	Prensaestopas	Monel® 400
36	Brida prensaestopas	Acero carbono
46	Empaquetadura	PTFE
49	Pasador	Acero carbono
50	Volante	Hierro maleable
52	Tornillo ojo	Acero carbono
54	Tuerca volante	Acero carbono
55	Junta cuerpo-tapa	Espirimetálica Monel® / PTFE
70	Husillo	K-Monel®
71	Obturador	Monel® 400
72	Tuerca obturador	Monel® 400
113	Pletina empuje	K-Monel®
98	Espárrago	ASTM A193 Gr. B7M

FIG. 3367P-HF8 - GLOBO ALQUILACIÓN 300LBS BRIDAS PHILLIPS

DIM.	DESCRIPCIÓN	TAMAÑO VÁLVULA				
		1/2"	3/4"	1"	1.1/2"	2"
A ₁	Distancia entre caras BRIDAS	152	178	203	229	267
K	Abierta	206	229	244	350	359
L	Cerrada	187	219	225	308	327
M	Diám. volante	89	114	114	23	203
	Peso (kg.)	4,5	6,8	10,0	20,0	28,6

GLOBO ALQUILACIÓN 600LBS PHILLIPS 1/2" - 2"

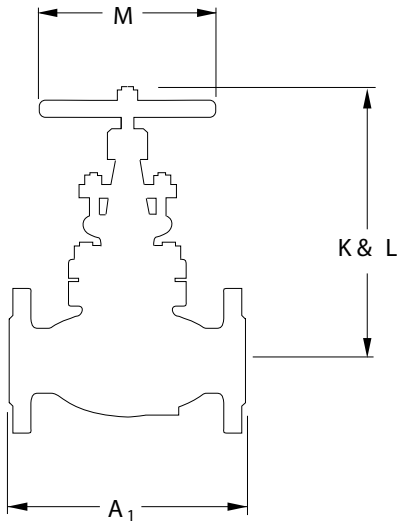

CRANE® PACIFIC Globo Fig. 3667P-HF8		Diseño: API 600
VÁLVULA GLOBO PARA SERVICIOS DE ALQUILACIÓN		
Especificaciones		
Material cuerpo	Acero carbono ASTM A216 Gr. WCB	
Obturador	Monel® 400	
Conexiones	Bridas, Roscadas o Socket Weld	
Rating	600LBS	
Pruebas	API 598 y API 622 "Packing Emission" para válvulas de proceso	
Fire Safe	Según API 607 (última edición)	
Presión prueba	Cuerpo: 2250 psig Asiento: 1650 psig Cuerpo (helio): 500 psig	
Aplicaciones	Fundamentalmente en la industria Petroquímica	

Componentes		
Pos.	Denominación	Material
10	Cuerpo	ASTM A216 Gr. WCB o ASTM A105
11	Asiento	Monel® 400
16a	Tuerca	Acero carbono
16b	Tuerca	ASTM A194 Gr. 2HM
30	Tapa	ASTM A216 Gr. WCB o ASTM A105
31	Tuerca guía husillo	12% Cromo o Bronce-Aluminio
35	Prensaestopas	Monel® 400
36	Brida prensaestopas	Acero carbono
46	Empaquetadura	PTFE
49	Pasador	Acero carbono
50	Volante	Hierro maleable
52	Tornillo ojo	Acero carbono
54	Tuerca volante	Acero carbono
55	Junta cuerpo-tapa	Espirometálica Monel® / PTFE
70	Husillo	K-Monel®
71	Obturador	Monel® 400
72	Tuerca obturador	Monel® 400
113	Pletina empuje	K-Monel®
98	Espárrago	ASTM A193 Gr. B7M

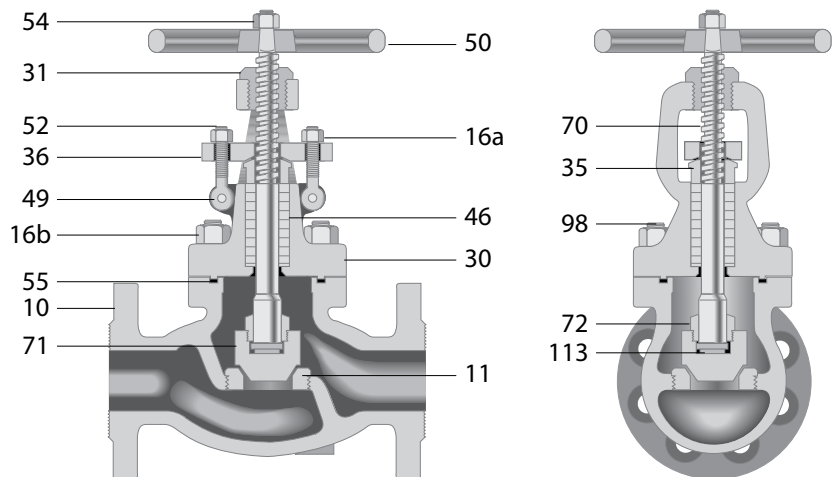

FIG. 3667P-HF8 - GLOBO ALQUILACIÓN 600LBS BRIDAS PHILLIPS

DIM.	DESCRIPCIÓN	TAMAÑO VÁLVULA					
		1/2"	3/4"	1"	1.1/4"	1.1/2"	2"
A ₁	Distancia entre caras BRIDAS	165	184	216	229	241	292
K	Abierta	184	229	238	292	308	388
L	Cerrada	175	213	226	276	286	337
M	Diám. volante	76	95	114	178	178	203
	Peso (kg.)	5	8	10	18	22	30

VÁLVULAS PARA ALQUILACIÓN

GLOBO ALQUILACIÓN 800LBS PHILLIPS 1/2" - 2"

CRANE® PACIFIC Globo Fig. 3668P-HF8 (-M35-1)		Diseño: API 602
VÁLVULA GLOBO PARA SERVICIOS DE ALQUILACIÓN		
Especificaciones		
Material cuerpo	ASTM A216 Gr. WCB o ASTM A105	
Obturador	Monel® 400	
Conexiones	Bridas, Roscadas o Socket Weld	
Rating	800LBS	
Pruebas	API 598 y API 622 "Packing Emission" para válvulas de proceso	
Fire Safe	Según API 607 (última edición)	
Presión prueba	Fig. 3668P-HF8 Cuerpo: 3000 psig Asiento: 2200 psig Cuerpo (helio): 500 psig	Fig. 3668P-HF8 (-M35-1) Cuerpo: 3000 psig Asiento: 2200 psig Cuerpo (helio): 500 psig
Aplicaciones	Fundamentalmente en la industria Petroquímica	

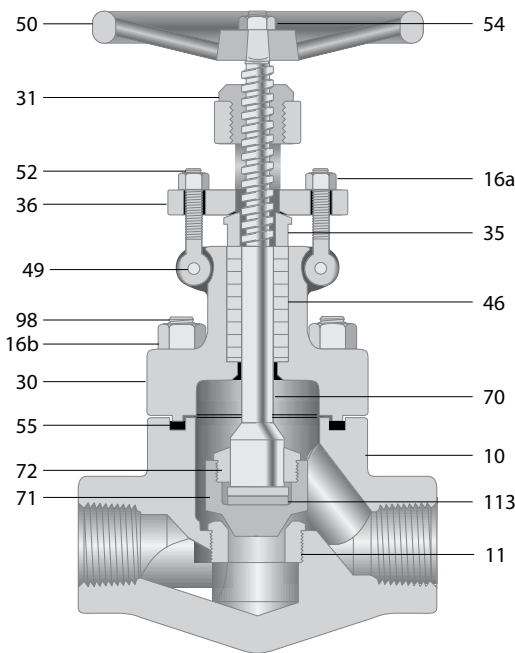
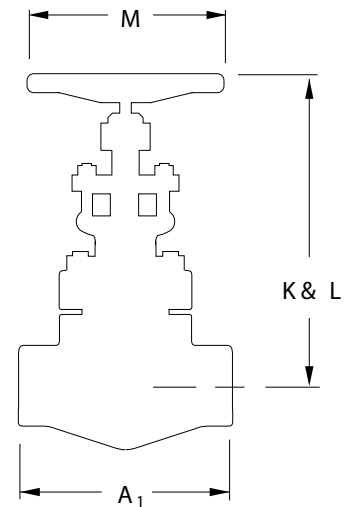

Pos.	Denominación	Componentes	
		Material	
		Fig. 3668P-HF8	Fig. 3668P-HF8 (-M35-1)
10	Cuerpo	ASTM A216 Gr. WCB o ASTM A105	ASTM A494 Gr. M35-1
11	Asiento	Monel® 400	Monel® 400
16a	Tuerca	Acero carbono	Acero carbono
16b	Tuerca	ASTM A194 Gr. 2HM	ASTM A194 Gr. 2HM
30	Tapa	ASTM A216 Gr. WCB o ASTM A105	ASTM A494 Gr. M35-1
31	Tuerca guía husillo	12% Cromo	12% Cromo
35	Prensaestopas	Monel® 400	Monel® 400
36	Brida prensaestopas	Acero carbono	Acero carbono
46	Empaquetadura	PTFE	PTFE
49	Pasador	Acero carbono	Acero carbono
50	Volante	Hierro maleable	Hierro maleable
52	Tornillo ojo	Acero carbono	Acero carbono
54	Tuerca volante	Acero carbono	Acero carbono
55	Junta cuerpo-tapa	Espirometálica Monel® / PTFE	Espirometálica Monel® / PTFE
70	Husillo	K-Monel®	K-Monel®
71	Obturador	Monel® 400	Monel® 400
72	Tuerca obturador	Monel® 400	Monel® 400
113	Pletina empuje	K-Monel®	K-Monel®
98	Espárrago	ASTM A193 Gr. B7M	ASTM A193 Gr. B7M

FIG. 3368P-HF8 (-M35-1) - GLOBO ALQUILACIÓN 800LBS NPT PHILLIPS

DIM.	DESCRIPCIÓN	TAMAÑO VÁLVULA					
		1/2"	3/4"	1"	1.1/4"	1.1/2"	2"
A _v	Distancia entre caras NPT	92	114	130	159	178	213
K	Abierta	191	220	242	299	334	362
L	Cerrada	178	213	226	286	309	331
M	Diám. volante	89	114	114	203	203	203
	Peso (kg.)	2,7	4,1	5,9	11,8	13,6	22,2

GLOBO ALQUILACIÓN 800LBS PHILLIPS 1/2" - 2"

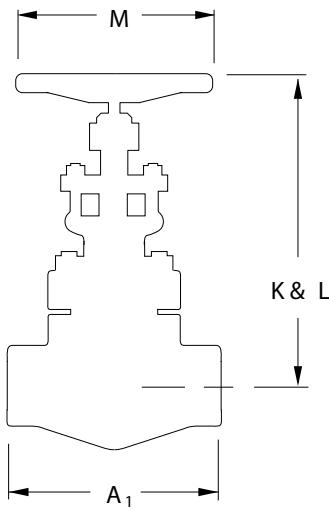

CRANE® PACIFIC Globo Fig. 3668P-HF8T (-M35-1)		Diseño: API 602
VÁLVULA GLOBO PARA SERVICIOS DE ALQUILACIÓN		
Especificaciones		
Material cuerpo	ASTM A216 Gr. WCB o ASTM A494 Gr. M35-1	
Asientos	Monel® 400	
Conexiones	Bridas, Roscadas o Socket Weld	
Rating	800LBS	
Pruebas	API 598 y API 622 "Packing Emission" para válvulas de proceso	
Fire Safe	Según API 607 (última edición)	
Presión prueba	Fig. 3668P-HF8T Cuerpo: 3000 psig Asiento: 2200 psig Cuerpo (helio): 500 psig	Fig. 3668P-HF8T (-M35-1) Cuerpo: 3000 psig Asiento: 2200 psig Cuerpo (helio): 500 psig
Aplicaciones	Fundamentalmente en la industria Petroquímica	

Pos.	Denominación	Componentes	
		Material	
		Fig. 3668P-HF8T	Fig. 3668P-HF8T (-M35-1)
10	Cuerpo	ASTM A216 Gr. WCB o ASTM A105	ASTM A494 Gr. M35-1
11	Asiento	Monel® 400	Monel® 400
16a	Tuerca	Acero carbono	Acero carbono
16b	Tuerca	ASTM A194 Gr. 2HM	ASTM A194 Gr. 2HM
30	Tapa	ASTM A216 Gr. WCB o ASTM A105	ASTM A494 Gr. M35-1
31	Tuerca guía husillo	12% Cromo	12% Cromo
35	Prensaestopas	Monel® 400	Monel® 400
36	Brida prensaestopas	Acero carbono	Acero carbono
46	Empaquetadura	PTFE	PTFE
49	Pasador	Acero carbono	Acero carbono
50	Volante	Hierro maleable	Hierro maleable
52	Tornillo ojo	Acero carbono	Acero carbono
54	Tuerca volante	Acero carbono	Acero carbono
55	Junta cuerpo-tapa	Espirometálica Monel® / PTFE	Espirometálica Monel® / PTFE
70	Husillo	K-Monel®	K-Monel®
71	Obturador	Monel® 400 con inserto de PTFE	Monel® 400 con inserto de PTFE
72	Tuerca obturador	Monel® 400	Monel® 400
113	Pletina empuje	K-Monel®	K-Monel®
98	Espárrago	ASTM A193 Gr. B7M	ASTM A193 Gr. B7M

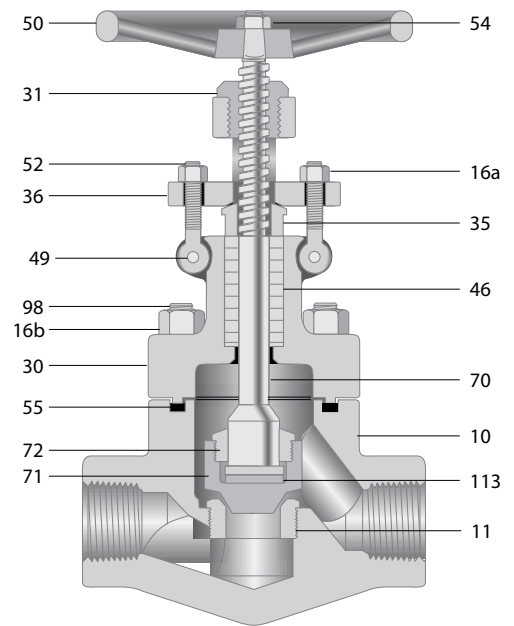

FIG. 3668P-HF8T (-M35-1) - GLOBO ALQUILACIÓN 800LBS NPT PHILLIPS

DIM.	DESCRIPCIÓN	TAMAÑO VÁLVULA					
		1/2"	3/4"	1"	1.1/4"	1.1/2"	2"
A ₁	Distancia entre caras NPT	92	114	130	159	178	213
K	Abierta	191	220	242	299	334	362
L	Cerrada	178	213	226	286	309	331
M	Diám. volante	89	114	114	203	203	203
	Peso (kg.)	2,7	4,1	5,9	11,8	13,6	22,2

VÁLVULAS PARA ALQUILACIÓN

GLOBO ALQUILACIÓN 300LBS PHILLIPS 1.1/2" - 12"

CRANE® PACIFIC Globo Fig. 360P-HF8		Diseño: API 600
VÁLVULA GLOBO PARA SERVICIOS DE ALQUILACIÓN		
Especificaciones		
Material cuerpo	Acero carbono ASTM A216 Gr. WCB	
Obturador	Monel® 400	
Conexiones	Bridas, Roscadas o Socket Weld	
Rating	300LBS	
Pruebas	API 598 y API 622 "Packing Emission" para válvulas de proceso	
Fire Safe	Según API 607 (última edición)	
Presión prueba	Cuerpo: 1125 psig Asiento: 825 psig Cuerpo (helio): 500 psig	
Aplicaciones	Fundamentalmente en la industria Petroquímica	

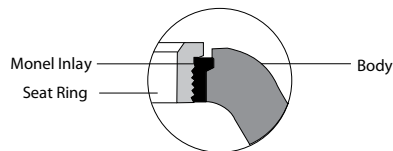
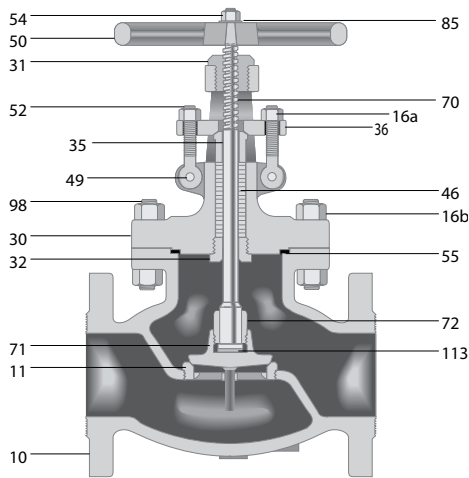
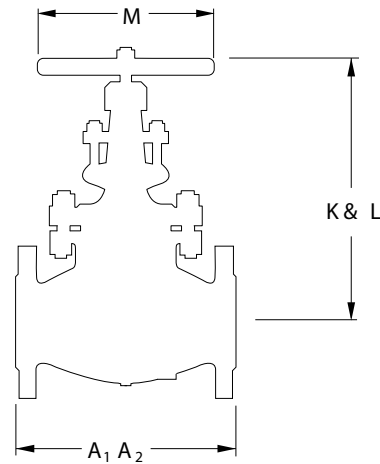

La Figura 360P-HF8 incluye asientos roscados con todas las piezas en Monel® 400

Componentes		
Pos.	Denominación	Material
54	Tuerca volante	Acero carbono
50	Volante	Fundición Dúctil
36	Brida prensaestopas	Acero carbono
35	Prensaestopas	Monel® 400
46	Empaquetadura	John Crane 124
98	Espárrago	ASTM A193 Gr. B7M
16b	Tuerca	ASTM A194 Gr. 2HM
30	Tapa	ASTM A216 Gr. WCB
55	Junta cuerpo-tapa	Espirometálica Monel® / PTFE
32	Casquillo husillo	Monel®
70	Husillo	Monel®
72	Tuerca obturador	Monel® 400
71	Obturador	Monel® 400
11	Asiento	Monel® 400
10	Cuerpo	ASTM A216 Gr. WCB
31	Tuerca guía husillo	Bronce-Aluminio o 12% Cromo
52	Tornillo ojo	Acero carbono
16a	Tuerca	Acero carbono
49	Pasador	Acero carbono
85	Arandela volante	12% Cromo
113	Pletina empuje	K-Monel®

FIG. 360P-HF8 - GLOBO ALQUILACIÓN 300LBS BRIDAS PHILLIPS

DIM.	DESCRIPCIÓN	TAMAÑO VÁLVULA									
		1.1/2"	2"	2.1/2"	3"	4"	6"	8"	10"	12"	
A ₁	Distancia entre caras RF	229	267	292	318	356	445	559	622	711	
A ₂	Distancia entre caras RTJ	241	283	308	333	371	460	575	638	727	
K	Abierta	397	464	508	527	632	730	797	873	1219	
L	Cerrada	365	435	476	479	581	657	724	800	1143	
M	Diám. volante	203	203	254	254	356	457	457	864	864	
	Peso (kg.)	27	36	47	62	102	176	288	571	770	

RETENCIÓN PISTÓN ALQUILACIÓN 800LBS PHILLIPS 1/2" - 2"

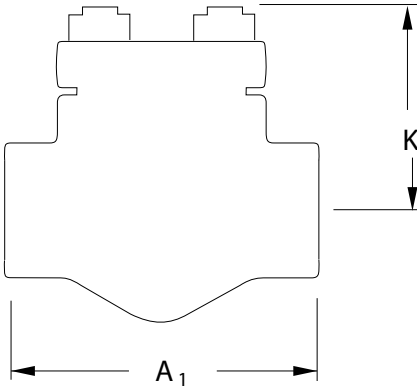

CRANE® PACIFIC Globo Fig. 3681P-HF8T (-M35-1)		Diseño: API 602
VÁLVULA GLOBO PARA SERVICIOS DE ALQUILACIÓN		
Especificaciones		
Material cuerpo	ASTM A216 Gr. WCB / A105 o ASTM A494 Gr. M35-1	
Obturador	Monel® 400	
Conexiones	Bridas, Roscadas o Socket Weld	
Rating	800LBS	
Fire Safe	Según API 607 (última edición)	
Presión prueba	Fig. 3681P-HF8 Cuerpo: 3000 psig Asiento: 2200 psig Cuerpo (helio): 500 psig	Fig. 3681P-HF8 (-M35-1) Cuerpo: 3000 psig Asiento: 2200 psig Cuerpo (helio): 500 psig
Aplicaciones	Fundamentalmente en la industria Petroquímica	

Pos.	Denominación	Componentes	
		Material	
		Fig. 3681P-HF8	Fig. 3681P-HF8 (-M35-1)
98	Espárrago	ASTM A193 Gr. B7M	ASTM A193 Gr. B7M
16	Tuerca	ASTM A194 Gr. 2HM	ASTM A193 Gr. 2HM
30	Tapa	ASTM A216 Gr. WCB o A515 Gr. 70	ASTM A494 Gr. M35-1
55	Junta cuerpo-tapa	Espirometálica Monel® / Grafito	Espirometálica Monel® / Grafito
71	Obturador	Monel® 400	Monel® 400
10	Cuerpo	ASTM A105 o ASTM A216 Gr. WCB	ASTM A494 Gr. M35-1
11	Asiento	Monel® 400	Monel® 400

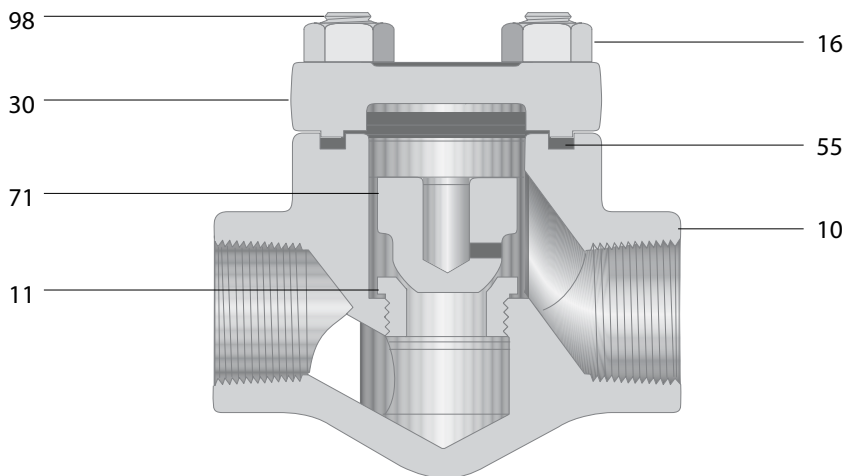

FIG. 3681P-HF8 (-M35-1) - RETENCIÓN A PISTÓN ALQUILACIÓN 800LBS NPT PHILLIPS

DIM.	DESCRIPCIÓN	TAMAÑO VÁLVULA				
		1/2"	3/4"	1"	1.1/2"	2"
A ₁	Distancia entre caras NPT	92	114	130	178	213
K	Altura desde el centro	64	76	87	127	140
	Peso (kg.)	1,4	2,7	4,1	9,1	15,9

VÁLVULAS PARA ALQUILACIÓN

RETENCIÓN CLAPETA ALQUILACIÓN 300LBS PHILLIPS 1.1/2" - 30"

CRANE® PACIFIC Retención Fig. 380P-HF8 (-M35-1)		Diseño: API 600
VÁLVULA RETENCIÓN A CLAPETA PARA SERVICIOS DE ALQUILACIÓN		
Especificaciones		
Material cuerpo	ASTM A216 Gr. WCB o ASTM A494 Gr. M35-1	
Obturador	Monel® 400 o ASTM A494 Gr. M35-1	
Conexiones	Bridas, Roscadas o Socket Weld	
Rating	300LBS	
Fire Safe	Según API 607 (última edición)	
Presión prueba	Cuerpo: 1125 psig Asiento: 825 psig Cuerpo (helico): 500 psig	
Aplicaciones	Fundamentalmente en la industria Petroquímica	

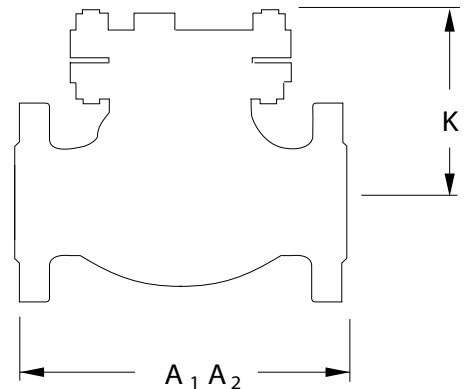

Pos.	Denominación	Componentes	
		Fig. 380P-HF8	Fig. 380P-HF8 (-M35-1)
98	Espárrago	ASTM A193 Gr. B7M	ASTM A193 Gr. B7M
16	Tuerca	ASTM A194 Gr. 2HM	ASTM A194 Gr. 2HM
30	Tapa	ASTM A216 Gr. WCB o A515 Gr. 70	ASTM A494 Gr. M35-1
55	Junta cuerpo-tapa	Espirometálica Monel® / PTFE	Espirometálica Monel® / PTFE
41	Bulón	K-Monel®	K-Monel®
40	Biela	Monel® 400	
10	Cuerpo	ASTM A216 Gr. WCB	ASTM A494 Gr. M35-1
72	Tuerca obturador	Monel® 400	Monel® 400
85	Arandela	Monel® 400	Monel® 400
71	Obturador	Monel® 400	Monel® 400
49	Pasador	Monel® 400	Monel® 400
12	Asiento	Monel® 400	Monel® 400
44	Tapón	Acero carbono	Monel® 400

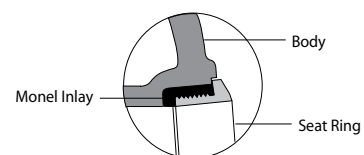
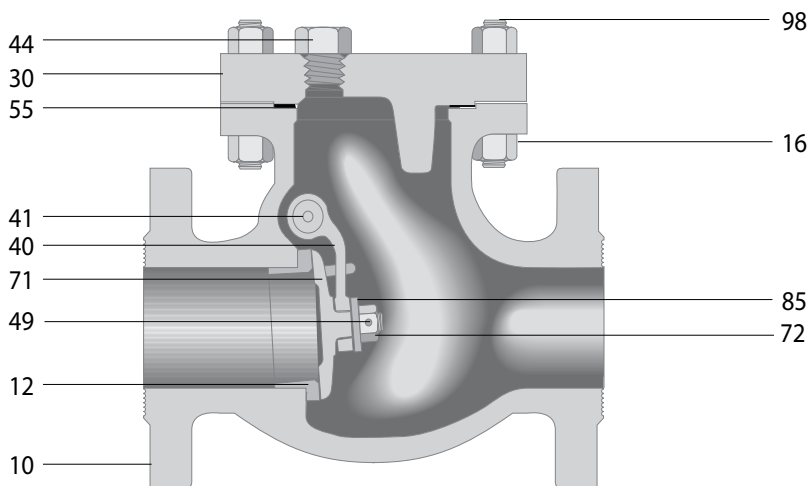

La Figura 380PX-HF8 incluye asientos roscados con todas las piezas en Monel® 400

FIG. 380P-HF8 - RETENCIÓN A CLAPETA ALQUILACIÓN 300LBS BRIDAS PHILLIPS

DIM.	DESCRIPCIÓN	TAMAÑO VÁLVULA														
		1.1/2"	2"	2.1/2"	3"	4"	6"	8"	10"	12"	14"	16"	18"	20"	24"	30"
A ₁	Distancia entre caras RF	241	267	292	318	356	445	533	622	711	838	864	978	1015	1346	1594
A ₂	Distancia entre caras RTJ	254	282	308	333	372	460	549	638	727	854	880	994	1035	1368	1619
K	Altura desde el centro	163	178	187	203	225	289	337	387	458	489	530	565	581	845	997
	Peso (kg.)	23	29	39	50	73	150	231	356	581	676	922	1110	1352	2195	2994

INYECTORES DE GRASA PARA ALQUILACIÓN

CRANE® PACIFIC Inyectores de grasa

PARA SERVICIOS DE ALQUILACIÓN

Especificaciones

El inyector doble que utilizan las válvulas PACIFIC posee una doble retención de tipo bola —para proteger frente a posibles fugas— y una válvula de cierre interna. El cabezal principal se debe desenroscar media vuelta con el fin de abrir la válvula interna antes de inyectar la grasa. Para este proceso se requiere una segunda llave para asegurarse de que el cuerpo del inyector no se suelta de la válvula principal. Una vez realizado el engrasado, el cabezal se ha de apretar para mantener la función de cierre.

Pos.	Denominación	Componentes	
		ACERO CARBONO	Monel®
1	Retención bola	Acero inox 302	Monel®
2	Muelle		
3	Carcasa principal	ASTM A108 Gr. 1018	Monel®
4	Aguja	ASTM A108 Gr. 1018	Monel®
5	Carcasa válvula	ASTM A108 Gr. 1018	Monel®
6	Retención bola	Monel®	Monel®
7	Retención bola	Monel®	Monel®
8	Pasador	ASTM A108 Gr. 1018	Monel®

Tamaño tubería NPT	Longitud
1/4"	3.1/16"
3/8"	3.1/16"

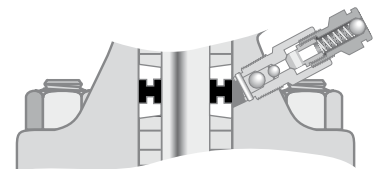
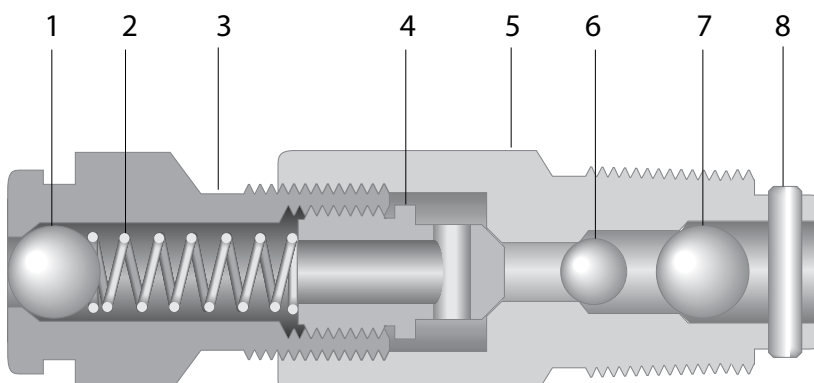

Inyector de grasa y anillo linterna en caja de empacquetadura para válvula de Compuerta o Globo

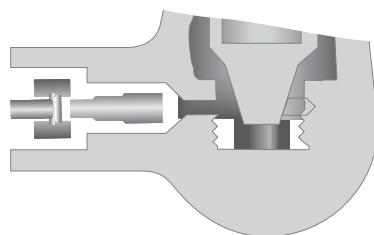

Inyector de grasa en Asiento y Obturador para válvula de Globo

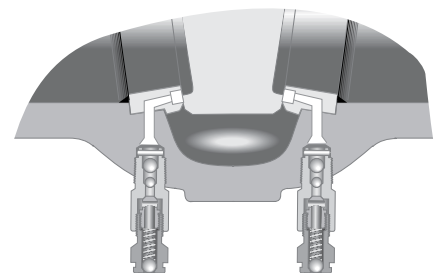

Inyector de grasa Doble en Asiento y cuña para válvula de Compuerta

DIN

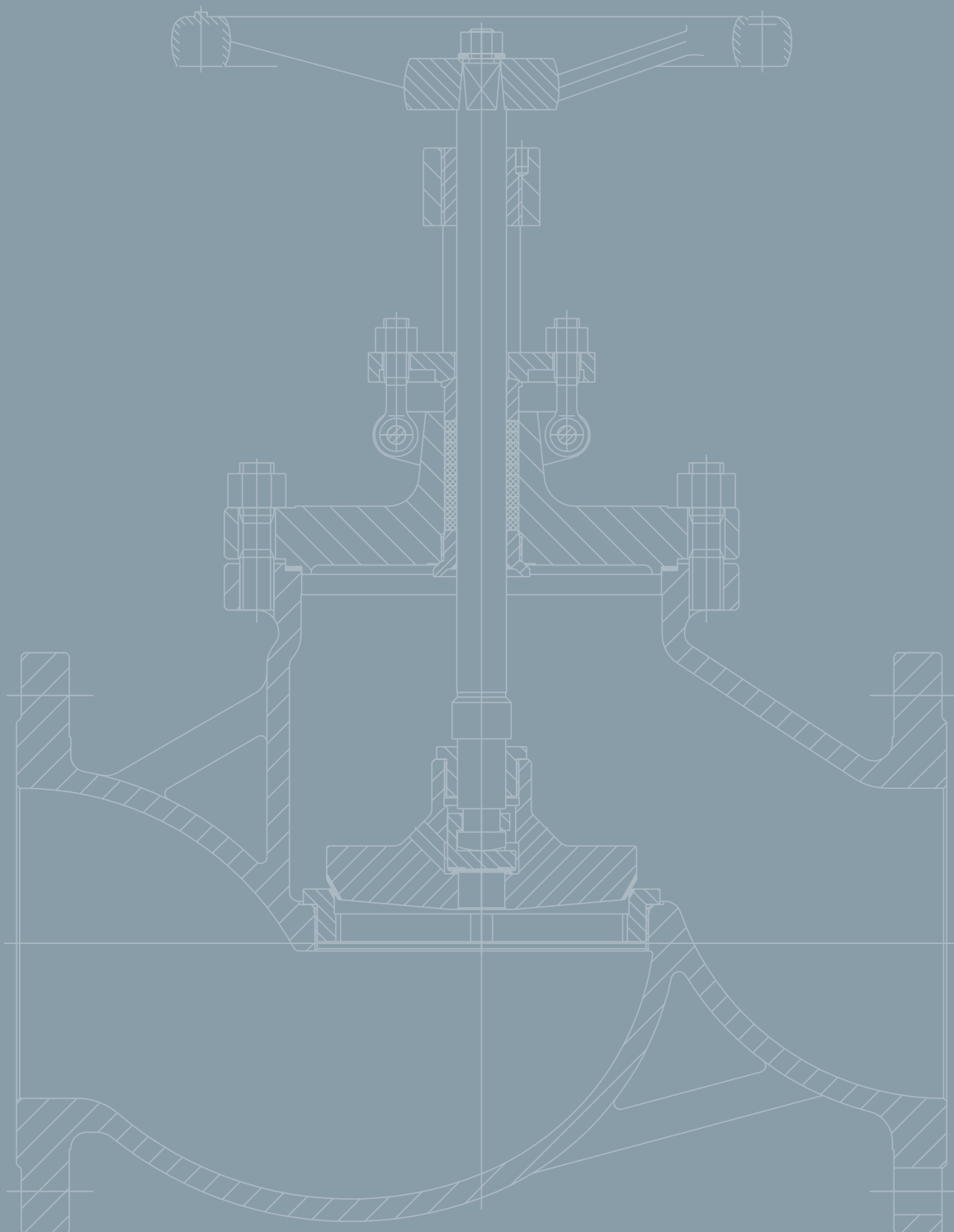

VÁLVULAS DIN



VÁLVULAS DIN

COMPUERTA HIERRO FUNDIDO PN16 DISTANCIA F5

RK® COMPUERTA Hierro Fundido		Distancia: F5
VÁLVULA COMPUERTA HIERRO FUNDIDO PN16 RF		
Materiales		
Cuerpo	Hierro Fundido GG25	
Asiento	13% Cr	
Cuña	GG25 + 13% Cr	
Husillo	13% Cr	
Empaquetadura	Grafito	
Junta cuerpo-tapa	Grafito/Acero	
Presiones		
Prueba hidráulica del cuerpo	2,4 MPa	
Prueba hidráulica del asiento	1,76 MPa	
Prueba neumática del asiento	0,6 MPa	
Normas		
Diseño y Fabricación	DIN 3352	
Bridas	DN40 a DN300 ¹⁾ según EN 1092-2	
Inspección y Pruebas	DIN 3230	
Distancia entre caras	EN 558-1 Serie 15 (ant. DIN 3202 F5)	
¹⁾ Otras medidas bajo demanda		

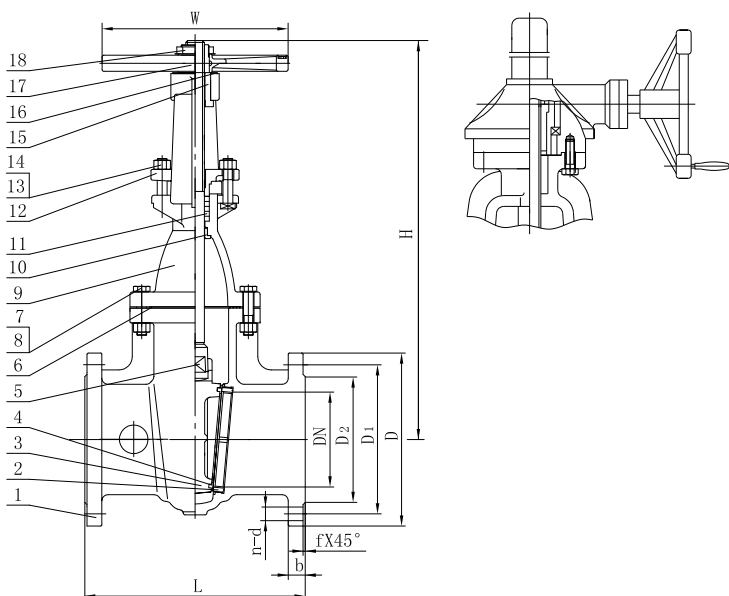

Componentes		
Pos.	Denominación	Material
1	Cuerpo	GG25
2	Asientos	13% Cr
3	Cuña	GG25
4	Anillo cuña	13% Cr
5	Husillo	13% Cr
6	Junta cuerpo-tapa	Grafito/Acero
7	Tornillo	ASTM A307
8	Tuerca	Acero carbono
9	Tapa	GG25
10	Cierre trasero	13% Cr
11	Empaquetadura	Grafito
12	Pletina prensaestopas	ASTM A536
13	Tornillo prensaestopas	Acero carbono
14	Tuerca prensaestopas	Acero carbono
15	Tuerca husillo	Mn Latón
16	Junta	ASTM B16
17	Volante	ASTM A126 Cl. B
18	Tuerca volante	ASTM A536

COMPUERTA GG25/13% CR PN16 RF H.EXT. F5

Código	DN	L	D	D1	D2	b	n-d	f	H	W	Peso (kg)
010108302720118	40	240	150	110	88	18	4-18	3	284	160	16
010108302720117	50	250	165	125	102	20	4-18	3	310	180	20
010108302720116	65	270	185	145	122	20	4-18	3	397	180	25
010108302720115	80	280	200	160	138	22	8-18	3	406	200	31
010108302720102	100	300	220	180	158	24	8-18	3	467	250	46
010108302720113	125	325	250	210	188	26	8-18	3	548	280	66
010108302720124	150	350	285	240	212	26	8-22	3	634	300	88
010108302720111	200	400	340	295	268	30	12-22	3	787	360	134
010108302720110	250	450	405	355	320	32	12-26	3	935	400	240
010108302720081	300	500	460	410	378	32	12-26	4	1078	420	328

COMPUERTA ACERO CARBONO PN10 DISTANCIA F4

SUFA® COMPUERTA Acero carbono		Distancia: F4
VÁLVULA COMPUERTA ACERO CARBONO PN10 RF		
Materiales		
Cuerpo	Acero Carbono GSC25	
Asiento	A105 + 13% Cr	
Cuña	GSC25 + 13% Cr	
Husillo	A182 F6	
Empaquetadura	Grafito	
Junta cuerpo-tapa	Acero inox/Grafito	
Presiones		
Prueba hidráulica del cuerpo	1,5 MPa	
Prueba hidráulica del asiento	1,1 MPa	
Prueba neumática del asiento	0,6 MPa	
Normas		
Diseño y Fabricación	DIN 3352	
Bridas	DN50 a DN250 ⁽¹⁾ según EN 1092-1	
Inspección y Pruebas	DIN 3230	
Distancia entre caras	EN 558-1 Serie 14 (ant. DIN 3202 F4)	
⁽¹⁾ Otras medidas bajo demanda		

Componentes		
Pos.	Denominación	Material
1	Cuerpo	GSC25
2	Asiento	A105 + 13% Cr
3	Cuña	GSC25 + 13% Cr
4	Husillo	A182 F6
5	Tuerca	A194 2H
6	Tornillo	A193 B7
7	Junta	304/Grafito
8	Tapa	GSC25
9	Empaquetadura	Grafito
10	Anillo espaciador	A182 F6
11	Pasador	ASTM A36
12	Tornillo	A193 B7
13	Prensaestopas	A182 F6
14	Brida prensaestopas	GSC25
15	Tuerca	A194 2H
16	Tuerca husillo	ZQA19-4
17	Tuerca puente	Acero carbono
18	Volante	Acero carbono
19	Tuerca	A194 2H
20	Tuerca	A194 2H
21	Tornillo	A193 B7
22	Puente	GSC25
23	Cojinetes	

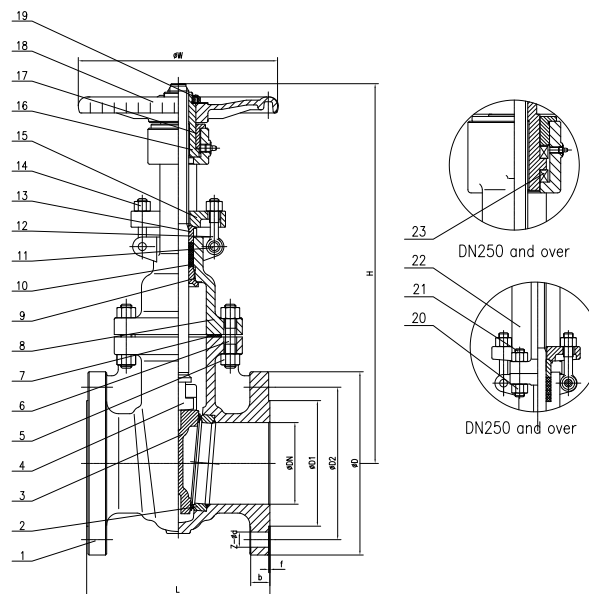

COMPUERTA GSC25/13% CR PN10 RF H.EXT. F4

Código	DN	L	D	D1	D2	f	b	Z-d	W	H
010108302720125	40	140	150	110	88	3	18	4-18	160	284
010108302720136	50	150	165	102	125	3	19	4-18	180	350
010108302720147	65	170	185	122	145	3	20	8-18	180	373
010108302720134	80	180	200	138	160	3	20	8-18	180	420
010108302720133	100	190	220	158	180	3	22	8-18	200	500
010108302720093	125	200	250	188	210	3	22	8-18	300	550
010108302720131	150	210	285	212	240	3	24	8-22	300	615
010108302720103	200	230	340	268	295	3	24	8-22	350	770
010108302720130	250	250	405	320	350	3	26	12-22	400	920

VÁLVULAS DIN

COMPUERTA ACERO CARBONO PN16 DISTANCIA F5

SUFA® COMPUERTA Acero carbono		Distancia: F5
VÁLVULA COMPUERTA ACERO CARBONO PN16 RF		
Materiales		
Cuerpo	Acero Carbono GSC25	
Asiento	13% Cr	
Cuña	GSC25	
Husillo	A182 F6	
Empaquetadura	Grafito	
Junta cuerpo-tapa	304/Grafito	
Presiones		
Prueba hidráulica del cuerpo	2,4 MPa	
Prueba hidráulica del asiento	1,76 MPa	
Prueba neumática del asiento	0,6 MPa	
Normas		
Diseño y Fabricación	DIN 3352 y BS EN 1984	
Bridas	DN40 a DN200 [□] según BS EN 1092-1	
Inspección y Pruebas	BS EN 12569 y DIN 3230	
Distancia entre caras	EN 558-1 Serie 15 (ant. DIN 3202 F5)	
□ Otras medidas bajo demanda		

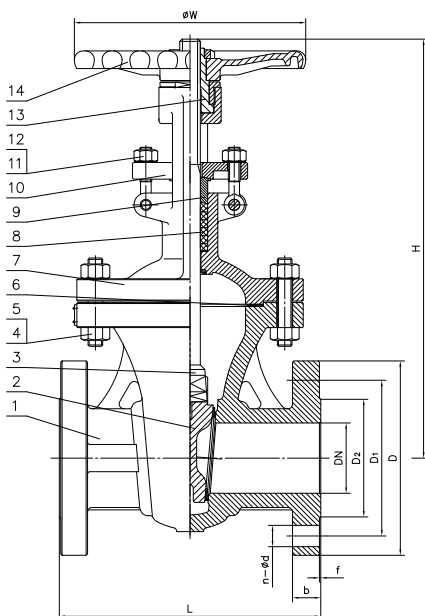

Componentes		
Pos.	Denominación	Material
1	Cuerpo	GSC25 + 13% Cr
2	Cuña	GSC25 + 13% Cr
3	Husillo	A182 F6
4	Tornillo	ASTM A193 B7
5	Tuerca	ASTM A194 2H
6	Junta cuerpo-tapa	Acero inox/Grafito
7	Tapa	GSC25
8	Empaquetadura	Grafito
9	Prensaestopas	ASTM A182 F6
10	Brida prensaestopas	GSC25
11	Tornillo ojo	Acero carbono
12	Tuerca	Acero carbono
13	Tuerca husillo	Aleación de cobre
14	Volante	ASTM A197

COMPUERTA GSC25/13% CR PN16 RF H.EXT. F5

Código	DN	L	D	D1	D2	f	b	n-d	W	H
-	40	240	150	110	88	2	18	4-18	200	296
010108302720128	50	250	165	125	102	2	18	4-18	200	361
010108302720127	65	270	185	145	122	2	18	8-18	200	380
010108302720126	80	280	200	160	138	2	20	8-18	250	418
010108302720137	100	300	220	180	158	2	20	8-18	280	488
010108302720095	125	325	250	210	188	2	22	8-18	300	531
010108302720076	150	350	285	240	212	2	22	8-22	360	638
010108302720075	200	400	340	295	268	2	24	12-22	360	758

COMPUERTA ACERO FUNDIDO PN40 DISTANCIA F7

SUFA® COMPUERTA Acero Carbono		Distancia: F7
VÁLVULA COMPUERTA ACERO CARBONO PN40 RF		
Materiales		
Cuerpo	Acero Carbono GSC25	
Asiento	13% Cr	
Cuña	GSC25	
Husillo	A182 F6	
Empaquetadura	Grafito	
Junta cuerpo-tapa	304/Grafito	
Presiones		
Prueba hidráulica del cuerpo	6,0 MPa	
Prueba hidráulica del asiento	4,4 MPa	
Prueba neumática del asiento	0,6 MPa	
Normas		
Diseño y Fabricación	DIN 3352 y BS EN 1984	
Bridas	DN50 a DN200 ¹⁾ según BS EN 1092-1	
Inspección y Pruebas	BS EN 12569 y DIN 3230	
Distancia entre caras	EN 558-1 Serie 26 (ant. DIN 3202 F7)	
¹⁾ Otras medidas bajo demanda		

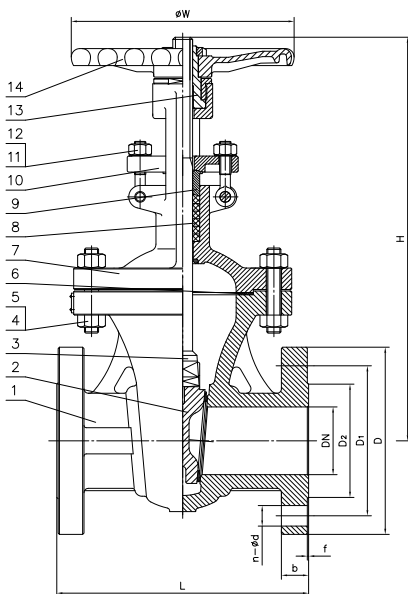

Componentes		
Pos.	Denominación	Material
1	Cuerpo	GSC25 + 13% Cr
2	Cuña	GSC25 + 13% Cr
3	Husillo	A182 F6
4	Tornillo	ASTM A193 B7
5	Tuerca	ASTM A194 2H
6	Junta cuerpo-tapa	Acero inox/Grafito
7	Tapa	GSC25
8	Empaquetadura	Grafito
9	Prensaestopas	ASTM A182 F6
10	Brida prensaestopas	GSC25
11	Tornillo ojo	Acero carbono
12	Tuerca	Acero carbono
13	Tuerca husillo	Aleación de cobre
14	Volante	ASTM A197

COMPUERTA GSC25/13% CR PN40 RF H.EXT. F7

Código	DN	L	D	D1	D2	f	b	n-d	H	W
010108302720079	50	250	165	125	102	3	20	4-18	358	200
010108302720181	65	290	185	145	122	3	22	8-18	373	250
010108302720182	80	310	200	160	138	3	24	8-18	435	250
010108302720183	100	350	235	190	162	3	24	8-22	500	280
010108302720184	125	400	270	220	188	3	24	8-26	614	300
010108302720199	150	450	300	250	218	3	28	8-26	674	300
010108302720186	200	550	375	320	285	3	30	12-30	818	350
010108302720174	250	650	450	385	345	3	32	12-33	969	400

VÁLVULAS DIN

GLOBO HIERRO FUNDIDO PN16 DISTANCIA F1

RK® Globo Hierro Fundido		Distancia: F1
VÁLVULA GLOBO HIERRO FUNDIDO PN16 RF		
Materiales		
Cuerpo	Hierro Fundido GG25	
Asiento	13% Cr	
Obturador	GG25 + 13% Cr	
Husillo	13% Cr	
Empaquetadura	Grafito	
Junta cuerpo-tapa	Acero/Grafito	
Presiones		
Prueba hidráulica del cuerpo	2,4 MPa	
Prueba hidráulica del asiento	1,76 MPa	
Prueba neumática del asiento	0,6 MPa	
Normas		
Diseño y Fabricación	DIN 3352	
Bridas	DN15 a DN250 ¹⁾ según BS EN 1092-2	
Inspección y Pruebas	DIN 3230	
Distancia entre caras	EN 558-1 Serie 1 (ant. DIN 3202 F1)	

¹⁾Otras medidas bajo demanda

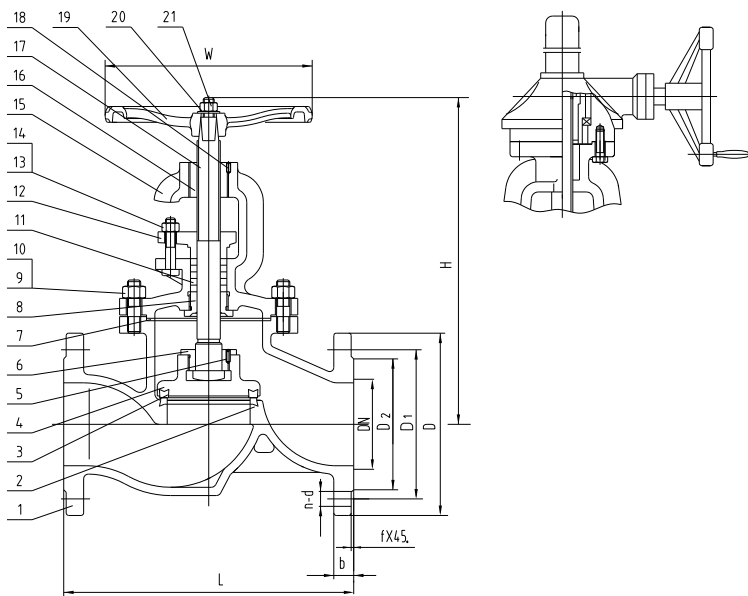

Componentes		
Pos.	Denominación	Material
1	Cuerpo	GG25
2	Asiento	13% Cr
3	Anillo asiento	13% Cr
4	Obturador	GG25
5	Tornillo	ASTM A307
6	Cubierta obturador	Acero carbono
7	Junta cuerpo-tapa	Grafito/Acero
8	Casquillo cierre trasero	13% Cr
9	Espárrago	Acero carbono
10	Tuerca	Acero carbono
11	Empaquetadura	Grafito
12	Prensaestopas	13% Cr
13	Tornillo	Acero carbono
14	Tuerca	Acero carbono
15	Tapa	GG25
16	Tuerca husillo	Mn Latón
17	Husillo	13% Cr
18	Tornillo	ASTM A307
19	Volante	ASTM A126 Cl.B
20	Arandela	Acero carbono
21	Tuerca	Acero carbono

GLOBO GG25/13% CR PN16 RF H.EXT. F1

Código	DN	L	D	D1	D2	b	n-d	f	H	W	Peso (kg)
010108302720189	15	130	95	65	45	14	4-14	2	182	65	4
010108302720190	20	150	105	75	58	16	4-14	2	185	65	5
010108302720191	25	160	115	85	68	16	4-14	2	201	80	6
010108302720192	32	180	140	100	78	18	4-18	2	253	120	10
010108302720193	40	200	150	110	88	18	4-18	3	254	120	12
010108302720194	50	230	165	125	102	20	4-18	3	277	180	16
010108302720195	65	290	185	145	122	20	4-18	3	312	200	25
010108302720196	80	310	200	160	138	22	8-18	3	342	250	34
010108302720197	100	350	220	180	158	24	8-18	3	378	250	43
010108302720198	125	400	250	210	188	26	8-18	3	447	300	71
010108302720161	150	480	285	240	212	26	8-22	3	503	360	95
010108302720159	200	600	340	295	268	30	12-22	3	591	400	160
010108302720080	250	730	405	355	320	32	12-26	3	680	450	260

GLOBO ACERO CARBONO PN40 DISTANCIA F1

SUFA® Globo Acero carbono		Distancia: F1
VÁLVULA GLOBO ACERO CARBONO PN40 RF		
Materiales		
Cuerpo	Acero Carbono GSC25	
Obturador	13% Cr	
Husillo	13% Cr	
Empaquetadura	Grafito	
Junta cuerpo-tapa	304/Grafito	
Presiones		
Prueba hidráulica del cuerpo	6,0 MPa	
Prueba hidráulica del asiento	4,4 MPa	
Prueba neumática del asiento	0,6 MPa	
Normas		
Diseño y Fabricación	DIN 3352	
Bridas	DN15 a DN250 ¹⁾ según DIN 2545	
Inspección y Pruebas	API 598	
Distancia entre caras	EN 558-1 Serie 1 (ant. DIN 3202 F1)	

¹⁾ Otras medidas bajo demanda

Componentes		
Pos.	Denominación	Material
1	Cuerpo	GSC25
2	Obturador	13% Cr
3	Anillo	13% Cr
4	Tuerca obturador	13% Cr
5	Junta	304/Grafito
6	Pasador	13% Cr
7	Empaquetadura	Grafito
8	Tuerca	Acero carbono
9	Espárrago	35 Cr Mn
10	Prensaestopas	13% Cr
11	Brida prensaestopas	GSC25
12	Tuerca	Acero carbono
13	Tornillo de ojo	35 Cr Mn
14	Husillo	13% Cr
15	Tapa	GSC25N
16	Tuerca husillo	GGG40
17	Tornillo	Acero carbono
18	Volante	GGG40
19	Arandela	13% Cr
20	Tuerca	Acero carbono

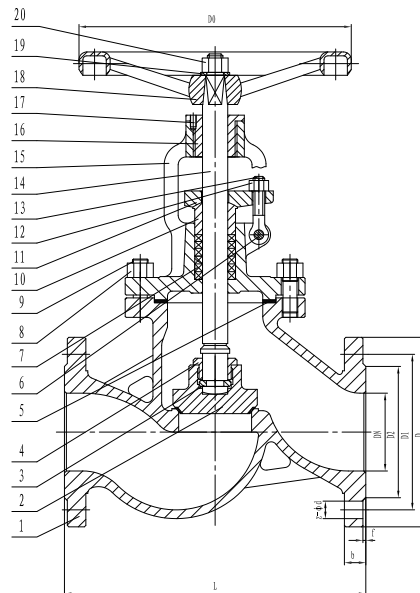

Diseño corresponde a DN65 - DN100

GLOBO GSC25/13% CR PN40 RF H.EXT. F1

Código	DN	L	D0	D	D1	D2	b	f	z-d	H
010108302720185	15	130	140	95	65	45	16	2	4-14	190
010108302720150	20	150	140	105	75	58	18	2	4-14	190
010108302720151	25	160	140	115	85	68	18	2	4-14	208
010108302720152	32	180	140	140	100	78	18	2	4-18	210
010108302720153	40	200	160	150	110	88	18	3	4-18	232
010108302720154	50	230	160	165	125	102	20	3	4-18	243
010108302720155	65	290	160	185	145	122	22	3	8-18	282
010108302720156	80	310	200	200	160	138	24	3	8-18	305
010108302720157	100	350	200	235	190	162	24	3	8-22	361
010108302720200	125	400	400	270	220	188	26	3	8-26	460
010108302720158	150	480	400	300	250	218	28	3	8-26	496
010108302720187	200	600	400	375	320	285	34	3	12-30	615
010108302720100	250	730	450	450	385	345	38	3	12-33	700

VÁLVULAS DIN

RETENCIÓN HIERRO FUNDIDO PN16 DISTANCIA F6

RK® Retención Hierro Fundido		Distancia: F6
VÁLVULA RETENCIÓN HIERRO FUNDIDO PN16 RF		
Materiales		
Cuerpo	Hierro Fundido GG25	
Asiento	13% Cr	
Clapeta	GG25 + 13% Cr	
Biela	Acero carbono	
Junta cuerpo-tapa	Acero/Grafito	
Presiones		
Prueba hidráulica del cuerpo	2,4 MPa	
Prueba hidráulica del asiento	1,76 MPa	
Normas		
Diseño y Fabricación	BS EN 12334	
Bridas	DN50 a DN250 [□] según BS EN 1092-2	
Inspección y Pruebas	BS EN 12266	
Distancia entre caras	EN 558-1 Serie 48 (ant. DIN 3202 F6)	
[□] Otras medidas bajo demanda		

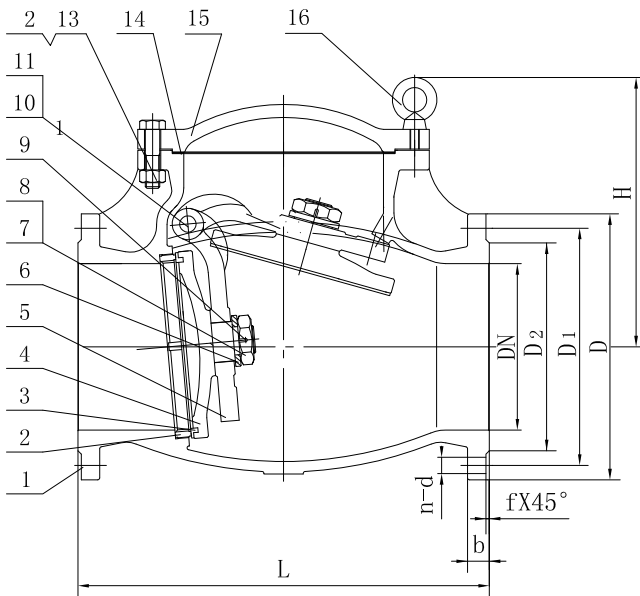

Componentes		
Pos.	Denominación	Material
1	Cuerpo	GG25
2	Asiento	13% Cr
3	Anillo obturador	13% Cr
4	Obturador	GG25
5	Biela	Acero carbono
6	Arandela	Acero carbono
7	Tuerca	Acero carbono
8	Espárrago	Acero carbono
9	Pasador	1Cr 18 Ni 9 Ti
10	Pasador biela	13% Cr
11	Tapón	Hierro maleable
12	Tornillo	Acero carbono
13	Tuerca	Acero carbono
14	Junta cuerpo-tapa	Acero/Grafito
15	Tapa	GG25
16	Tornillo ojo	Acero carbono

RETENCIÓN GG25/13% CR PN16 RF H.EXT. F6

Código	DN	L	D	D1	D2	b	n-d	f	H	Peso (kg)
010108302720173	50	200	165	125	102	20	4-18	3	150	18
010108302720160	65	240	185	145	122	20	4-18	3	160	21
010108302720148	80	260	200	160	138	22	8-18	3	170	28
010108302720162	100	300	220	180	158	24	8-18	3	180	36
010108302720163	125	350	250	210	188	26	8-18	3	215	52
010108302720164	150	400	285	240	212	26	8-22	3	260	62
010108302720165	200	500	340	295	268	300	12-22	3	294	108
010108302720085	250	600	405	355	320	32	12-26	3	370	191

RETENCIÓN ACERO CARBONO PN16 DISTANCIA F1

SUFA® Retención Acero carbono		Distancia: F1
VÁLVULA RETENCIÓN ACERO CARBONO PN16 RF		
Materiales		
Cuerpo	Acero Carbono GSC25	
Asiento	13% Cr	
Clapeta	13% Cr	
Biela	GSC25	
Junta cuerpo-tapa	304/Grafito	
Presiones		
Prueba hidráulica del cuerpo	2,4 MPa	
Prueba hidráulica del asiento	1,76 MPa	
Normas		
Diseño y Fabricación	DIN 3840 y BS 1868	
Bridas	DN40 a DN250 ¹⁾ según BS EN 1092-1	
Inspección y Pruebas	BS EN 12569 y DIN 3230	
Distancia entre caras	EN 558-1 Serie 1 (ant. DIN 3202 F1)	
¹⁾ Otras medidas bajo demanda		

Componentes		
Pos.	Denominación	Material
1	Cuerpo	GSC25
2	Clapeta	GSC25
3	Tuerca obturador	Acero carbono
4	Biela	GSC25
5	Bulón	ASTM A276 410
6	Tornillo tapa	ASTM A193 B7
7	Tuerca tapa	ASTM A194 2H
8	Junta cuerpo-tapa	304/Grafito
9	Tapa	GSC25
10	Argolla	Acero carbono
11	Tapón	ASTM A193 B7

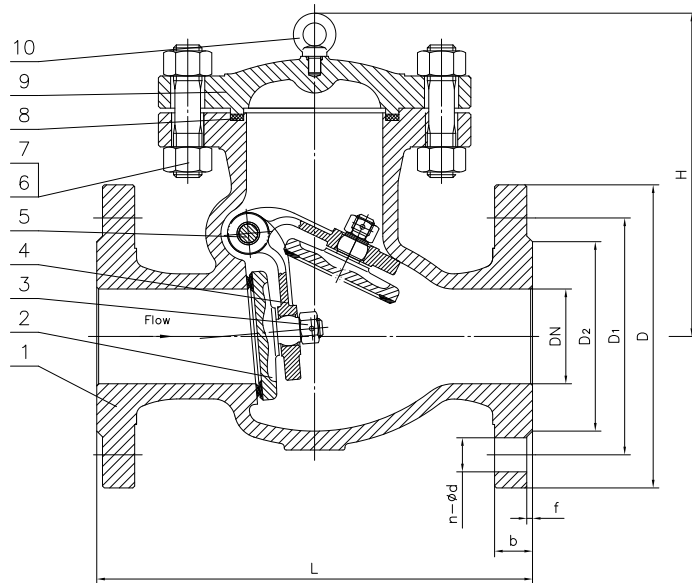
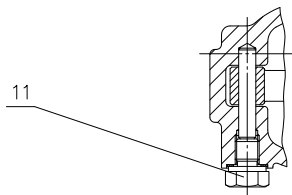

RETENCIÓN GSC25/13% CR PN16 RF H.EXT. F1

Código	DN	L	D	D1	D2	b	f	n-d	H
-	40	200	150	110	88	18	2	4-18	129
-	50	230	165	125	102	18	2	4-18	147
-	65	290	185	145	122	18	2	8-18	161
-	80	310	200	160	138	20	2	8-18	178
-	100	350	220	180	158	20	2	8-18	190
-	125	400	250	210	188	22	2	8-18	265
-	150	480	285	240	212	22	2	8-22	285
-	200	600	340	295	268	24	2	12-22	345
-	250	730	405	355	320	26	2	12-26	394

VÁLVULAS DIN

RETENCIÓN ACERO CARBONO PN40 DISTANCIA F1

SUFA® Retención Acero carbono		Distancia: F1
VÁLVULA RETENCIÓN ACERO CARBONO PN40 RF		
Materiales		
Cuerpo	Acero carbono GSC25	
Asiento	13% Cr	
Clapeta	GSC25	
Biela	GSC25	
Junta cuerpo-tapa	304/Grafito	
Presiones		
Prueba hidráulica del cuerpo	6,0 MPa	
Prueba hidráulica del asiento	4,4 MPa	
Normas		
Diseño y Fabricación	DIN 3840 y BS 1868	
Bridas	DN40 a DN250 [□] según BS EN 1092-2	
Inspección y Pruebas	BS EN 12569 y DIN 3230	
Distancia entre caras	EN 558-1 Serie 1 (ant. DIN 3202 F1)	
[□] Otras medidas bajo demanda		

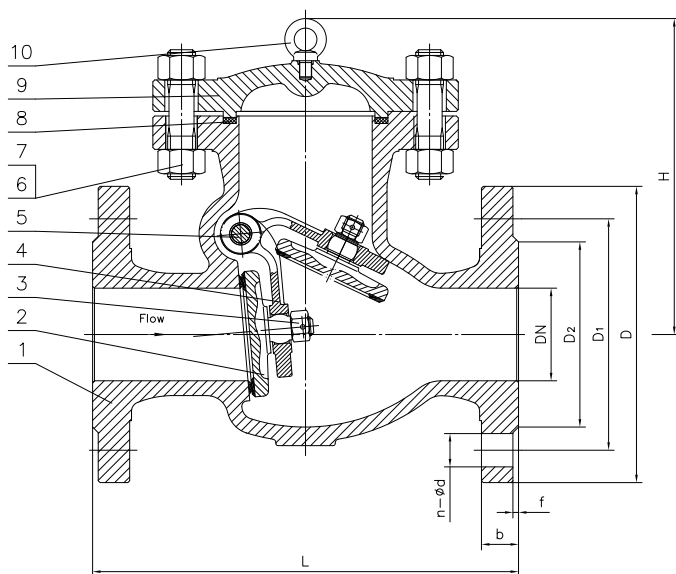

Componentes		
Pos.	Denominación	Material
1	Cuerpo	GSC25
2	Clapeta	GSC25
3	Tuerca obturador	Acero carbono
4	Biela	GSC25
5	Bulón	ASTM A276 410
6	Tornillo tapa	ASTM A193 B7
7	Tuerca tapa	ASTM A194 2H
8	Junta cuerpo-tapa	304/Grafito
9	Tapa	GSC25
10	Tornillo ojo	Acero carbono
11	Tapón	ASTM A193 B7

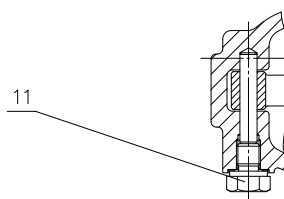

RETENCIÓN GSC25/13% CR PN40 RF H.EXT. F1

Código	DN	L	D	D1	D2	b	f	n-d	H
-	40	200	150	110	88	18	2	4-18	135
010108302720166	50	230	165	125	102	20	2	4-18	147
010108302720167	65	290	185	145	122	22	2	8-18	161
010108302720168	80	310	200	160	138	24	2	8-18	178
010108302720169	100	350	235	190	162	24	2	8-22	190
010108302720170	125	400	270	220	188	26	2	8-26	265
010108302720171	150	480	300	250	218	28	2	8-26	285
010108302720172	200	600	375	320	285	34	2	12-30	332
-	250	730	450	385	345	38	2	12-33	395

VÁLVULAS PARA USO NAVAL



VÁLVULAS DIN

COMPUERTA HIERRO FUNDIDO NAVAL PN10 DISTANCIA F4

RK® COMPUERTA Hierro Fundido		Distancia: F4
VÁLVULA COMPUERTA HIERRO FUNDIDO PN10 RF		
Materiales		
Cuerpo	Hierro Fundido GG25	
Asiento	Latón (o 13% Cr)	
Cuña	GG25 + B62	
Husillo	13% Cr	
Empaquetadura	Grafito	
Junta cuerpo-tapa	Acero/Grafito	
Presiones		
Prueba hidráulica del cuerpo	1,5 MPa	
Prueba hidráulica del asiento	1,1 MPa	
Normas		
Diseño y Fabricación	DIN EN1171	
Bridas	DN40 a DN300 □ según DIN EN 1092-2	
Inspección y Pruebas	EN 12266.1 RATE D	
Distancia entre caras	EN 558-1 Serie 14 (ant. DIN 3202 F4)	
□ Otras medidas bajo demanda		

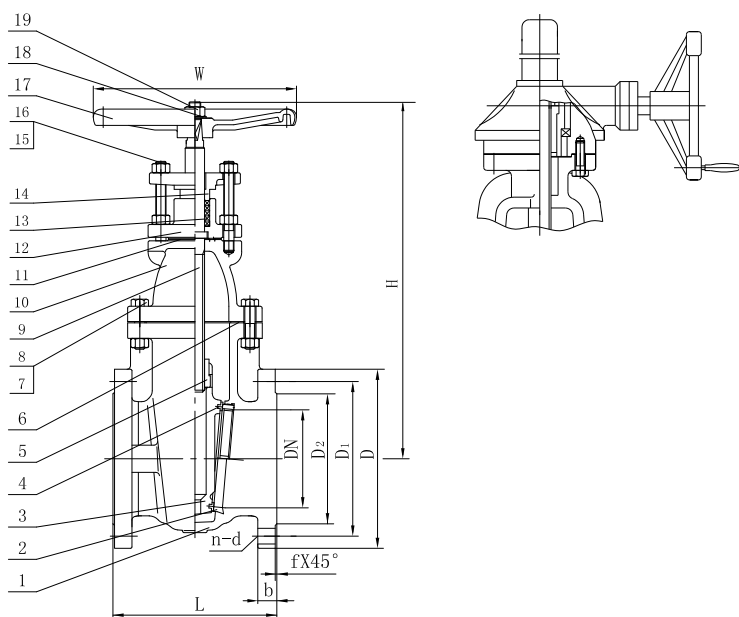

Componentes		
Pos.	Denominación	Material
1	Cuerpo	EN-JL 1040 (GG25)
2	Asientos	Latón (o 13% Cr)
3	Cuña	EN-JL 1040 (GG25)
4	Anillo cuña	EN1982 CC491K (o 13% Cr)
5	Tuerca cuña	EN1982 CC765S (Latón)
6	Junta cuerpo-tapa	Grafito + Acero
7	Tornillo tapa	S235JR (St 37.2)
8	Tuerca tapa	S235JR (St 37.2)
9	Husillo	X20 Cr13
10	Tapa	EN-JL1040 (GG25)
11	Junta prensaestopas	Grafito + Acero
12	Prensaestopas	EN-JL1040 (GG25)
13	Empaquetadura	Grafito
14	Brida prensaestopas	EN-JS1050 (GGG50)
15	Tornillo prensaestopas	S235JR (St 37.2)
16	Tuerca prensaestopas	S235JR (St 37.2)
17	Volante	EN-JL1040 (GG25)
18	Arandela	S235JR (St 37.2)
19	Tuerca	S235JR (St 37.2)

COMPUERTA GG25/B62 PN10 RF H.INT. F4

Código	DN	L	D	D1	D2	b	n-d	f	H	W	Peso (kg)
010108302720066	40	140	150	110	88	18	4-18	3	270	160	14
010108302720077	50	150	165	125	102	20	4-18	3	290	160	16
010108302720065	65	170	185	145	122	20	4-18	3	318	160	21
010108302720063	80	180	200	160	138	22	8-18	3	360	180	26
010108302720062	100	190	220	180	158	24	8-18	3	407	250	35
010108302720061	125	200	250	210	188	26	8-18	3	467	250	52
010108302720060	150	210	285	240	212	26	8-22	3	533	280	65
010108302720059	200	230	340	295	268	26	8-22	3	604	360	104
010108302720058	250	250	395	350	320	28	12-22	3	744	360	165
010108302720057	300	270	445	400	370	28	12-22	4	857	400	235

GLOBO Y RETENCIÓN HIERRO FUNDIDO NAVAL PN16 DISTANCIA F1

RK® Globo y Retención Hierro Fundido		Distancia: F1
VÁLVULA GLOBO Y RETENCIÓN HIERRO FUNDIDO PN16 RF		
Materiales		
Cuerpo	Hierro Fundido GG25	
Asiento	Bronce ASTM B62	
Disco	GG25 + B62	
Husillo	Latón ASTM B16	
Empaquetadura	Grafito	
Junta cuerpo-tapa	Acero/Grafito	
Presiones		
Prueba hidráulica del cuerpo	2,4 MPa	
Prueba hidráulica del asiento	1,76 MPa	
Prueba neumática del asiento	0,6 MPa	
Normas		
Diseño y Fabricación	DIN 3352	
Bridas	DN15 a DN200 ¹⁾ según DIN 2533	
Inspección y Pruebas	DIN 3230	
Distancia entre caras	EN 558-1 Serie 1 (ant. DIN 3202 F1)	
¹⁾ Otras medidas bajo demanda		

Componentes		
Pos.	Denominación	Material
1	Cuerpo	Hierro fundido GJL-250
2	Asiento	Bronce ASTM B62
3	Anillo asiento	Bronce ASTM B62
4	Obturador	Hierro fundido GJL-250
5	Junta cuerpo-tapa	Acero/Grafito
6	Espárrago	Acero carbono
7	Tuerca	Acero carbono
8	Tapa	Hierro fundido GJL-250
9	Empaquetadura	Grafito
10	Prensaestopas	Hierro fundido GJL-250
11	Tornillo	Acero carbono
12	Tuerca	Acero carbono
13	Husillo	Latón ASTM B16
14	Tuerca husillo	Mn Latón
15	Tornillo	Acero carbono
16	Volante	Hierro fundido GJL-250
17	Arandela	Acero carbono
18	Tuerca	Acero carbono

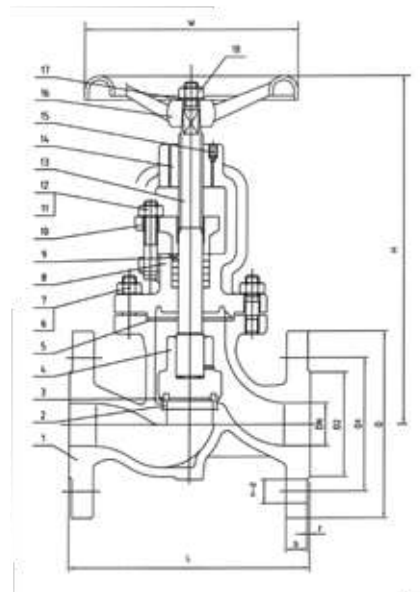

GLOBO Y RETENCIÓN GG25/B62 PN16 RF F1

Código	DN	L	D	D ₁	D ₂	b	n-d	f	H	W
010108302720104	15	130	95	65	45	14	4-14	2	182	65
010108302720135	20	150	105	75	58	16	4-14	2	185	65
010108302720112	25	160	115	85	68	16	4-14	2	201	80
010108302720114	32	180	140	100	78	18	4-18	2	253	120
010108302720146	40	200	150	110	88	18	4-18	3	254	120
010108302720145	50	230	165	125	102	20	4-18	3	277	180
010108302720144	65	290	185	145	122	20	4-18	3	312	200
010108302720143	80	310	200	160	138	22	8-18	3	342	250
010108302720142	100	350	220	180	158	24	8-18	3	378	250
010108302720141	125	400	250	210	188	26	8-18	3	447	300
010108302720140	150	480	285	240	212	26	8-22	3	503	360
010108302720087	200	600	340	295	268	30	12-22	3	591	400

VÁLVULAS DIN

GLOBO Y RETENCIÓN ACERO CARBONO NAVAL PN40 DISTANCIA F1

SUFA® Globo y Retención Acero carbono		Distancia: F1
VÁLVULA GLOBO Y RETENCIÓN ACERO CARBONO PN40 RF		
Materiales		
Cuerpo	Acero carbono GSC25	
Asiento	Bronce ASTM B62	
Obturador	A105	
Husillo	Latón	
Empaquetadura	Grafito	
Junta cuerpo-tapa	304/Grafito	
Presiones		
Prueba hidráulica del cuerpo	6,0 MPa	
Prueba hidráulica del asiento	4,4 MPa	
Normas		
Diseño y Fabricación	BS EN 13709 y BS 1873	
Bridas	DN15 a DN150 □ según BS EN 1092-1	
Inspección y Pruebas	BS EN 12569 y DIN 3230	
Distancia entre caras	EN 558-1 Serie 1 (ant. DIN 3202 F1)	
□ Otras medidas bajo demanda		

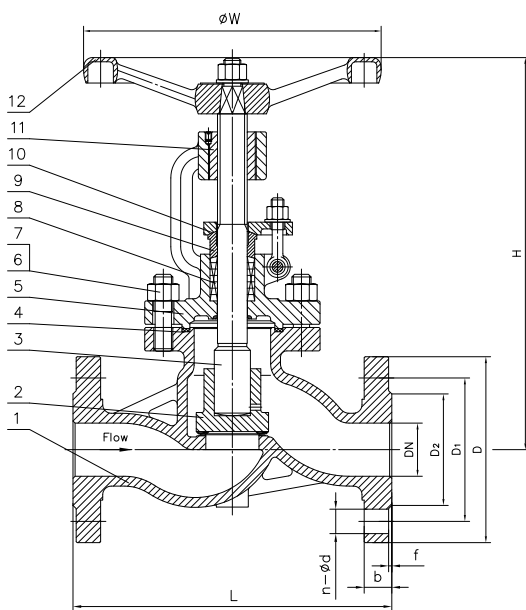

Componentes		
Pos.	Denominación	Material
1	Cuerpo	GSC25 + Bronce
2	Asientos	ASTM A105 + Bronce
3	Husillo	Bronce
4	Junta	304/Grafito
5	Tapa	GSC25
6	Tornillo cuerpo-tapa	ASTM A193 B7
7	Tuerca cuerpo-tapa	ASTM A194 2H
8	Empaquetadura	Grafito
9	Prensaestopas	ASTM A276 410
10	Brida prensaestopas	GSC25
11	Tuerca husillo	Aleación de cobre
12	Volante	ASTM A197

GLOBO Y RETENCIÓN GSC25/BRONCE PN40 RF H. EXT. F1

Código	DN	D	D1	D2	b	f	n-d	L	H	W	Peso (kg)
-	15	95	65	45	16	2	4-14	130	190	100	
-	20	105	75	58	18	2	4-14	150	210	100	
-	25	115	85	68	18	2	4-14	160	235	100	
010108302720139	32	140	100	78	18	2	4-18	180	235	140	
010108302720138	40	150	110	88	18	2	4-18	200	285	160	16
010108302720073	50	165	125	102	20	2	4-18	230	310	180	18
010108302720072	65	185	145	122	22	2	8-18	290	340	250	28
010108302720070	80	200	160	138	24	2	8-18	310	370	250	38
010108302720069	100	235	190	162	24	2	8-22	350	420	320	61
010108302720068	125	270	220	188	26	2	8-26	400	480	400	76
010108302720056	150	300	250	218	28	2	8-26	480	560	400	107

GLOBO Y RET. ANGULAR F. NODULAR NAVAL PN10 DIST. F5

SUFA® Globo y Retención Angular Fund. Nodular		Distancia: F5
VÁLVULA GLOBO Y RETENCIÓN FUND. NODULAR PN10 RF		
Materiales		
Cuerpo	Fundición Nodular GGG40	
Asiento	Acero inox 304	
Disco	GGG40 + 304	
Husillo	1.4301	
Empaquetadura	Grafito	
Junta cuerpo-tapa	Espirometálica Acero/Grafito	
Presiones		
Prueba hidráulica del cuerpo	1,5 MPa	
Prueba hidráulica del asiento	1,1 MPa	
Prueba neumática del asiento	0,6 MPa	
Normas		
Bridas	DN15 a DN100 ¹ según DIN 2501	
Inspección y Pruebas	DIN 3230	
Distancia entre caras	EN 558-1 Serie 15 (ant. DIN 3202 F5)	
¹ Otras medidas bajo demanda		

Componentes		
Pos.	Denominación	Material
1	Cuerpo	GGG40 + 304
2	Disco	GGG40 + 304
3	Empaquetadura	Grafito
4	Pasador	ASTM A193 B7
5	Tornillo	ASTM A193 B7
6	Tuerca	ASTM A194 2H
7	Tuerca	ASTM A194 2H
8	Volante	GGG40
9	Tuerca husillo	GGG40
10	Husillo	1.4301
11	Brida prensaestopas	GGG40
12	Tornillo	ASTM A193 B7
13	Tuerca	ASTM A194 2H
14	Junta cuerpo-tapa	Espirometálica Acero/Grafito
15	Tapa	GGG40

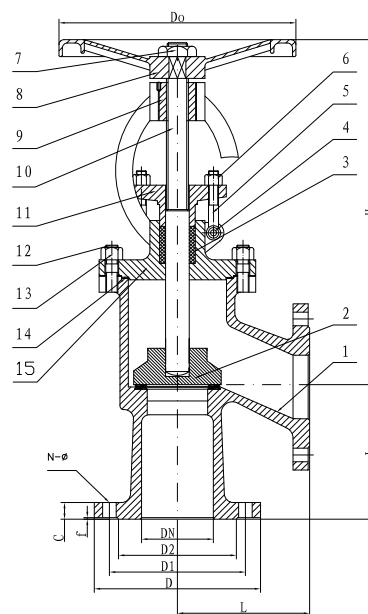

GLOBO Y RETENCIÓN ANGULAR GGG40/304 PN10 RF F5

Código	DN	L	D	D1	D2	C	f	N-Ø	H	D0
-	15	90	95	65	45	14	2	4-14	203	120
-	20	95	105	75	58	16	2	4-14	203	140
-	25	100	115	85	68	16	2	4-14	203	140
-	32									
-	40	115	150	110	88	18	3	4-18	236	200
010101302721553	50	125	165	125	102	20	3	4-18	250	200
010101302721545	65	145	185	145	122	20	3	4-18	307	240
-	80	155	200	160	138	22	3	8-18	328	240
-	100	175	220	180	158	24	3	8-18	368	320

VÁLVULAS DIN

GLOBO ANGULAR ACERO CARBONO NAVAL PN16 DISTANCIA F5

SUFA® Globo Angular Acero carbono		Distancia: F5
VÁLVULA GLOBO ANGULAR ACERO CARBONO PN16 RF		
Materiales		
Cuerpo	Acero carbono GSC25	
Asiento	Acero inox 304	
Obturador	1.0460 + 304	
Husillo	1.4301	
Empaquetadura	Grafito	
Junta cuerpo-tapa	Espirometálica Acero/Grafito	
Presiones		
Prueba hidráulica del cuerpo	2, MPa	
Prueba hidráulica del asiento	1,78 MPa	
Prueba neumática del asiento	0,6 MPa	
Normas		
Bridas	DN15 a DN200 [†] según DIN 2501	
Inspección y Pruebas	DIN 3202	
Distancia entre caras	EN 558-1 Serie 15 (ant. DIN 3202 F5)	

[†]Otras medidas bajo demanda

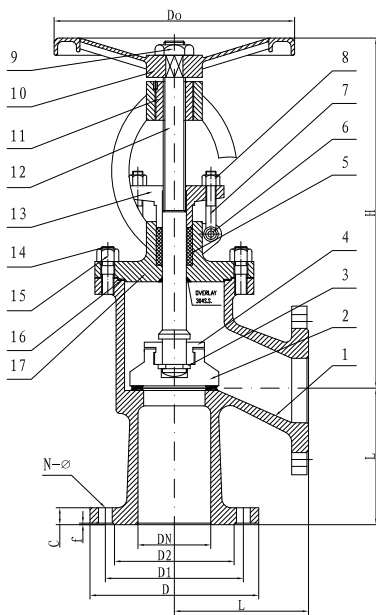

Componentes		
Pos.	Denominación	Material
1	Cuerpo	GGG25 + 304
2	Disco	1.0460 + 304
3	Anillo retenedor	1.4301
4	Tuerca disco	1.0460
5	Empaquetadura	Grafito
6	Pasador	ASTM A193 B7
7	Tornillo	ASTM A193 B7
8	Tuerca	ASTM A194 2H
9	Tuerca	ASTM A194 2H
10	Volante	GGG40
11	Tuerca husillo	GGG40
12	Husillo	1.4301
13	Brida prensaestopas	GSC25
14	Tornillo	ASTM A193 B7
15	Tuerca	ASTM A194 2H
16	Junta cuerpo-tapa	Espirometálica 304/Grafito
17	Tapa	GSC25 + 304

GLOBO ANGULAR GSC25/INOX PN16 RF H. EXT. F5

Código	DN	L	D	D1	D2	C	f	N-Ø	H	D ₀
-	15	90	95	65	45	16	2	4-14	203	120
-	20	95	105	75	58	18	2	4-14	203	140
-	25	100	115	85	68	18	2	4-14	203	140
-	32									
-	40	115	150	110	88	18	3	4-18	236	200
010101302721585	50	125	165	125	102	20	3	4-18	250	200
010101302721606	65	145	185	145	122	20	3	4-18	307	240
-	80	155	200	160	138	22	3	8-18	328	240
-	100	175	220	180	158	24	3	8-18	368	320
-	150	225	285	240	212	24	3	8-22	452	360
-	200	275	340	295	268	24	3	12-22	565	500

EJECUCIONES ESPECIALES

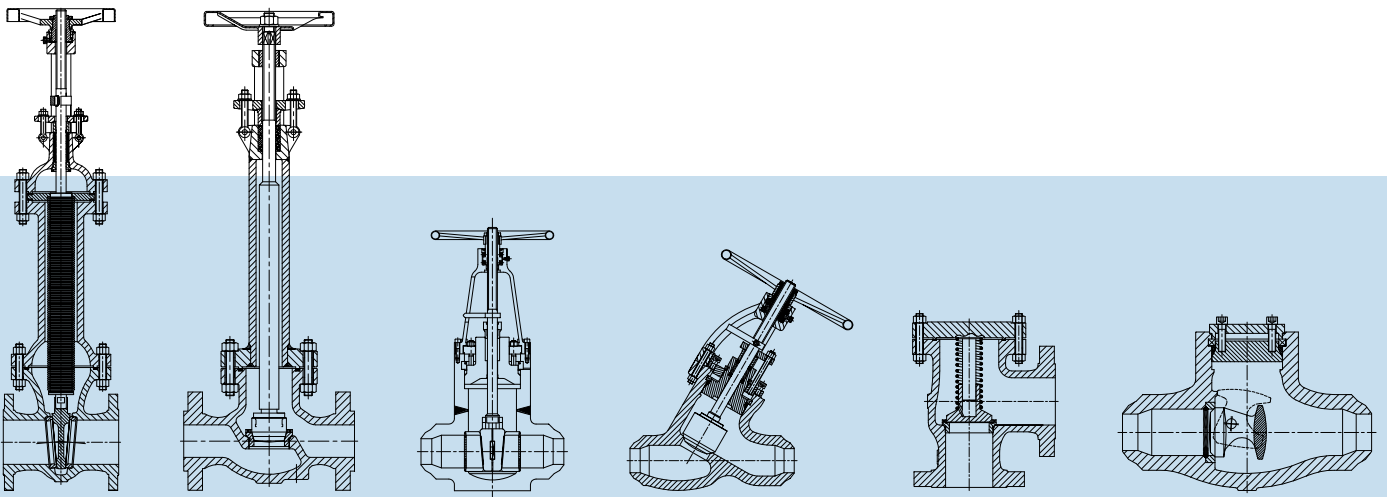

DIN EJECUCIONES ESPECIALES

COMPUERTA CRIOGÉNICA ACERO INOX PN16/100

COMPUERTA Acero inoxidable Fig. 12x0EB		Distancia: F5 / F7
VÁLVULA COMPUERTA ACERO INOXIDABLE RF		
Materiales		
Cuerpo	Acero inoxidable	
Asiento	Acero inoxidable	
Obturador	Acero inoxidable	
Husillo	Acero inoxidable	
Empaquetadura	PTFE	
Junta cuerpo-tapa	PTFE	
Normas		
Bridas	DN50 a DN600 [□] según DIN 2501	
Inspección y Pruebas	DIN 3352 Part 1 y DIN 3230 Part 3	
Distancia entre caras	EN 558-1 (ant. DIN 3202)	
[□] Otras medidas bajo demanda		

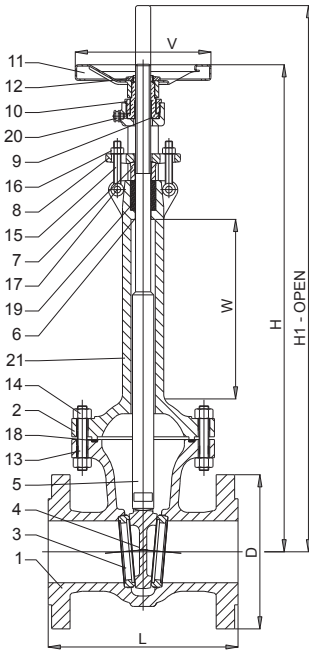
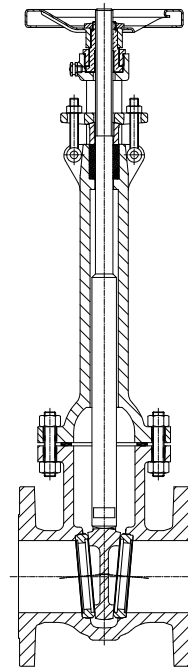

Componentes			
Pos.	Denominación	Materiales estándar (*)	
1	Cuerpo	1.4552	1.4581
2	Tapa	1.4552	1.581
3	Superficie asientos	X6 Cr Ni Ti 18 10	X5 Cr Ni Mo 17 12 2
4	Superficie cuña	X6 Cr Ni Ti 18 10	X5 Cr Ni Mo 17 12 2
5	Husillo	X6 Cr Ni Ti 18 10	X5 Cr Ni Mo 17 12 2
6	Cierre trasero	1.4552	1.4581
7	Prensaestopas	X6 Cr Ni Ti 18 10	X5 Cr Ni Mo 17 12 2
8	Brida prensaestopas	X6 Cr Ni Ti 18 10	X5 Cr Ni Mo 17 12 2
9	Tuerca guía husillo	Latón Ms 58	Latón Ms 58
10	Tuerca puente	X6 Cr Ni Ti 18 10	X5 Cr Ni Mo 17 12 2
11	Volante	Acero	Acero
12	Tuerca volante	X6 Cr Ni Ti 18 10	X5 Cr Ni Mo 17 12 2
13	Tornillos	A2 70	A2 70
14	Tuercas	A2 70	A2 70
15	Tornillos de ojo	A2 70	A2 70
16	Tuercas	A2 70	A2 70
17	Pasador tornillo ojo	A2 70	A2 70
18	Junta cuerpo-tapa	PTFE	PTFE
19	Empaquetadura	PTFE	PTFE
20	Nipple engrase	1.4404	1.4404
21	Extensión	X2 Cr Ni 19 11	X2 Cr Ni Mo 17 12 2

(*) Otros materiales bajo demanda

FIG. 1200EB - COMPUERTA CRIOGÉNICA 1.4552/INOX PN16 RF H. EXT. F5

DN	50	65	80	100	125	150	200	250	300	350	400	450	500	600
L (RF/BW)	250	270	280	300	325	350	400	450	500	550	600	650	700	800
D	165	185	200	220	250	285	340	405	460	520	580	640	715	840
V	200	200	225	250	280	300	400	500	500	600	600	600	600	600
W	200	200	300	300	300	300	300	300	300	300	300	300	300	300
H	600	630	800	820	910	920	1080	1350	1500	1700	1880	2050	2200	2600
H1	650	695	880	920	1020	1060	1280	1600	1840	2050	2280	2500	2750	3300

FIG. 1210EB - COMPUERTA CRIOGÉNICA 1.4552/INOX PN25 RF H. EXT. F5

DN	50	65	80	100	125	150	200	250	300	350	400	450	500	600
L (RF/BW)	250	270	280	300	325	350	400	450	500	550	600	650	700	800
D	165	185	200	220	250	285	340	405	460	520	580	640	715	840
V	200	200	225	250	280	300	400	500	500	600	600	600	600	600
W	200	200	300	300	300	300	300	300	300	300	300	300	300	300
H	600	630	800	820	910	920	1080	1350	1500	1700	1880	2050	2200	2600
H1	650	695	880	920	1020	1060	1280	1600	1840	2050	2280	2500	2750	3300

FIG. 1220EB - COMPUERTA CRIOGÉNICA 1.4552/INOX PN40 RF H. EXT. F7

DN	50	65	80	100	125	150	200	250	300	350	400	450	500	600
L (RF/BW)	250	290	310	350	400	450	550	650	750	850	950	1050	1150	1350
D	165	185	200	235	270	300	375	450	515	580	660	685	755	890
V	200	200	225	250	280	300	400	500	500	600	600	600	600	600
W	200	200	300	300	300	300	300	300	300	300	300	300	300	300
H	600	630	800	820	910	1000	1200	1350	1500	1700	1880	2050	2200	2600
H1	650	695	880	920	1020	1140	1400	1600	1840	2050	2280	2500	2750	3300

FIG. 1230EB - COMPUERTA CRIOGÉNICA 1.4552/INOX PN63 RF H. EXT. F7

DN	50	65	80	100	125	150	200	250	300	350	400	450	500	600
L (RF/BW)	250	290	310	350	400	450	550	650	750	850	950	-	1150	1350
D	180	205	215	250	295	345	415	470	530	600	670	-	800	930
V	200	250	250	400	400	500	600	700	700	800	1000	-	1000	1200
W	200	200	300	300	300	300	300	300	300	300	300	-	300	300
H	650	700	840	970	985	1110	1270	1455	1630	1800	1980	-	2400	2700
H1	700	770	920	1080	1110	1280	1480	1720	1960	2180	2400	-	2950	3400

FIG. 1240EB - COMPUERTA CRIOGÉNICA 1.4552/INOX PN100 RF H. EXT. F7

DN	50	65	80	100	125	150	200	250	300	350	400	450	500	600
L (RF/BW)	250	290	310	350	400	450	550	650	750	850	950	-	1150	1350
D	195	220	230	265	315	355	430	505	585	655	715	-	870	990
V	200	250	250	400	400	500	600	700	700	800	1000	-	1000	1200
W	200	200	300	300	300	300	300	300	300	300	300	-	300	300
H	650	700	840	970	985	1110	1270	1455	1630	1800	1980	-	2400	2700
H1	700	770	920	1080	1110	1280	1480	1720	1960	2180	2400	-	2950	3400

DIN EJECUCIONES ESPECIALES

COMPUERTA CON FUELLE PN16/100

COMPUERTA con Fuelle Acero Fig. 12x0SO		Distancia: F5 / F7
VÁLVULA COMPUERTA CON FUELLE ACERO RF		
Materiales estándar		
Cuerpo	Acero carbono 1.0619	
Asiento	Acero inoxidable 13% Cr	
Obturador	Acero inoxidable	
Husillo	Acero inoxidable 13% Cr	
Empaquetadura	Grafito	
Junta cuerpo-tapa	Ac. inox / Grafito	
Normas		
Bridas	DN50 a DN600 [□] según DIN 2501	
Inspección y Pruebas	DIN 3352 Part 1 y DIN 3230 Part 3	
Distancia entre caras	EN 558-1 (ant. DIN 3202)	
[□] Otras medidas bajo demanda		

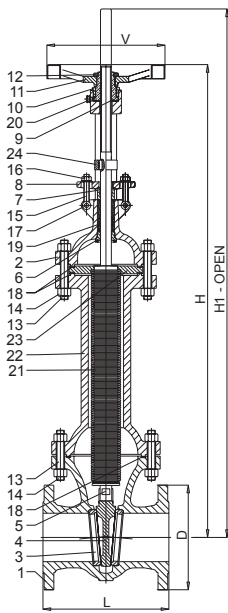
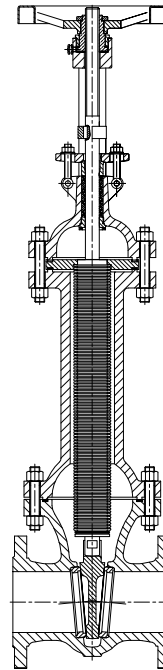

Pos.	Denominación	Componentes			
		Materiales estándar (*)			
1	Cuerpo	1.0619	1.7365	1.4552	1.4581
2	Tapa	1.0619	1.7365	1.4552	1.4581
3	Superficie asientos cuerpo	X20 Cr 13	X20 Cr 13 + HF	X6 Cr Ni Ti 18 10	X5 Cr Ni Mo 17 12 2
4	Superficie asientos cuña	X20 Cr 13	X20 Cr 13 + HF	X6 Cr Ni Ti 18 10	X5 Cr Ni Mo 17 12 2
5	Husillo	X20 Cr 13	X20 Cr 13	X6 Cr Ni Ti 18 10	X5 Cr Ni Mo 17 12 2
6	Cierre trasero	X20 Cr 13	X20 Cr 13	X6 Cr Ni Ti 18 10	X5 Cr Ni Mo 17 12 2
7	Prensaestopas	X20 Cr 13	X20 Cr 13	X6 Cr Ni Ti 18 10	X5 Cr Ni Mo 17 12 2
8	Brida prensaestopas	1.0460	X5 Cr Ni Mo 17 12 2	X6 Cr Ni Ti 18 10	X5 Cr Ni Mo 17 12 2
9	Tuerca guía husillo			Ms 58	
10	Tuerca puente	1.0460	1.0460	X6 Cr Ni Ti 18 10	X5 Cr Ni Mo 17 12 2
11	Volante			Acero	
12	Tuerca volante	1.0460	1.0460	X6 Cr Ni Ti 18 10	X5 Cr Ni Mo 17 12 2
13	Tornillos	CK 35	21 Cr Mo V 57	A2 70	A2 70
14	Tuercas	C 35	24 Cr Mo 5	A2 70	A2 70
15	Tornillos de ojo	CK 35	24 Cr Mo 5	A2 70	A2 70
16	Tuercas	C 35	24 Cr Mo 5	A2 70	A2 70
17	Pasador tornillo de ojo	CK 35	24 Cr Mo 5	A2 70	A2 70
18	Junta cuerpo-tapa			Ac. inox / Grafito	
19	Empaquetadura			Grafito	
20	Nipple engrase			Acero	
21	Fuelle	X6 Cr Ni Ti 18 10	X6 Cr Ni Ti 18 10	X6 Cr Ni Ti 18 10	X6 Cr Ni Ti 18 10
22	Extensión	1.0460	1.7363	X6 Cr Ni Nb 18 10	X2 Cr Ni Mo 17 12 2
23	Brida FUELLE			X6 Cr Ni Ti 18 10	
24	Dispositivo bloqueo	X20 Cr 13	X20 Cr 13	X6 Cr Ni Ti 18 10	X5 Cr Ni Mo 17 12 2

(*) Otros materiales bajo demanda

FIG. 1200SO - COMPUERTA FUELLE 1.0619/INOX PN16 RF H. EXT. F5

DN	50	65	80	100	125	150	200	250	300	350	400	450	500	600
L (RF/BW)	250	270	280	300	325	350	400	450	500	550	600	650	700	800
D	165	185	200	220	250	285	340	405	460	520	580	640	715	840
V	200	200	225	250	280	300	400	500	500	600	600	600	600	600
H	610	675	820	940	1160	1530	1960	2530	2600	2980	3170	2550	4050	4650
H1	660	740	900	1040	1290	1680	2160	2600	2900	3350	3570	4000	4550	5250

FIG. 1210SO - COMPUERTA FUELLE 1.0619/INOX PN25 RF H. EXT. F5

DN	50	65	80	100	125	150	200	250	300	350	400	450	500	600
L (RF/BW)	250	270	280	300	325	350	400	450	500	550	600	650	700	800
D	165	185	200	235	270	300	360	425	485	555	620	670	730	845
V	200	200	225	250	280	300	400	500	500	600	600	600	600	600
H	610	675	820	940	1160	1530	1960	2530	2600	2980	3170	2550	4050	4650
H1	660	740	900	1040	1290	1680	2160	2600	2900	3350	3570	4000	4550	5250

FIG. 1220SO - COMPUERTA FUELLE 1.0619/INOX PN40 RF H. EXT. F7

DN	50	65	80	100	125	150	200	250	300	350	400	450	500	600
L (RF/BW)	250	290	310	350	400	450	550	650	750	850	950	1050	1150	1350
D	165	185	200	235	270	300	375	450	515	580	660	685	755	890
V	200	200	225	250	280	300	400	500	500	600	600	600	600	600
H	600	685	765	920	1070	1315	1700	2035	2395	2760	3135	3600	4080	4795
H1	650	750	840	1020	1200	1465	1900	2285	2700	3110	4535	4050	4580	5350

FIG. 1230SO - COMPUERTA FUELLE 1.0619/INOX PN63 RF H. EXT. F7

DN	50	65	80	100	125	150	200	250	300	350	400	450	500	600
L (RF/BW)	250	290	310	350	400	450	550	650	750	850	950	-	1150	1350
D	180	205	215	250	295	345	415	470	530	600	670	-	800	930
V	200	250	250	400	400	500	600	700	700	800	1000	-	1000	1200
H	650	685	805	905	1070	1360	1720	2120	2500	-	-	-	-	-
H1	700	750	880	1010	1200	1510	1920	2370	2800	-	-	-	-	-

FIG. 1240SO - COMPUERTA FUELLE 1.0619/INOX PN100 RF H. EXT. F7

DN	50	65	80	100	125	150	200	250	300	350	400	450	500	600
L (RF/BW)	250	290	310	350	400	450	550	650	750	850	950	-	1150	1350
D	195	220	230	265	315	355	430	505	585	655	715	-	870	990
V	200	250	250	400	400	500	600	700	700	800	1000	-	1000	1200
H	650	685	805	905	1070	1360	1720	2120	2500	-	-	-	-	-
H1	700	750	880	1010	1200	1510	1920	2370	2800	-	-	-	-	-

DIN EJECUCIONES ESPECIALES

COMPUERTA PRESSURE SEAL PN 100/420

COMPUERTA Pressure Seal Acero Fig. P2x		Distancia: F8
VÁLVULA COMPUERTA PRESSURE SEAL ACERO PN100 RF		
Materiales estándar		
Cuerpo	Acero carbono	
Asiento	Acero	
Obturador	Acero inoxidable	
Husillo	Acero inoxidable 13% Cr	
Empaquetadura	Grafito	
Junta cuerpo-tapa	Ac. inox / Grafito	
Normas		
BW	DN50 a DN600 ^(*) según DIN 3239	
Inspección y Pruebas	DIN 3352 Part 1 y DIN 3230 Part 3	
Distancia entre caras	EN 558-1 Serie 99 (ant. DIN 3202 F8)	
^(*) Otras medidas bajo demanda		

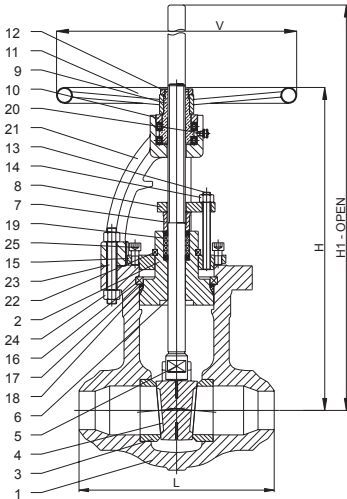
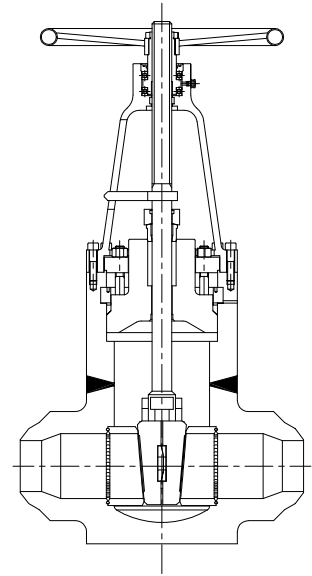

Pos.	Denominación	Componentes				
		Materiales estándar (*)				
1	Cuerpo	1.0619	1.5419	1.7357	1.7379	1.4581
2	Tapa	1.0619	1.5419	1.7357	1.7379	1.4581
3	Superficie asientos cuerpo	1.0160 +HF	1.0160 +HF	1.0460 +HF	1.0160 +HF	1.4401 +HF
4	Superficie asientos cuña	1.0619 +HF	1.5419 +HF	1.7357 +HF	1.7380 +HF	1.4581 +HF
5	Husillo	X20 Cr 13	X20 Cr 13	X20 Cr 13	X20 Cr 13	1.4401
6	Cierre trasero (integral)			Stellite		
7	Prensaestopas	X20 Cr 13	X20 Cr 13	X20 Cr 13	X20 Cr 13	1.4401
8	Brida prensaestopas	1.0460	1.4401	1.4401	1.4401	1.4401
9	Tuerca guía husillo			GGG50		
10	Tuerca puente	1.0460	1.0460	1.0460	1.0460	1.4401
11	Volante			Acero		
12	Tuerca volante			1.0460		
13	Tornillos	CK 35	21Cr Mo V 57	21 Cr Mo V 57	21Cr Mo V 57	A2 70
14	Tuercas	C 35	24 Cr Mo 5	24 Cr Mo 5	24 Cr Mo 5	A2 70
15	Brida retén	1.0160	1.0160	1.0460	1.0160	1.4401
16	Anillo retén	X20 Cr 13	X20 Cr 13	X20 Cr 13	X20 Cr 13	1.4401
17	Anillo espaciador	X20 Cr 13	X20 Cr 13	X20 Cr 13	X20 Cr 13	1.4401
18	Junta cuerpo-tapa			Ac. inox / Grafito		
19	Empaquetadura			Grafito		
20	Nipple engrase			Acero		
21	Puente	1.0619	1.5419	1.7357	1.7380	1.4581
22	Anillo soporte segmentado	X20 Cr 13	X20 Cr 13	X20 Cr 13	X20 Cr 13	1.4401
23	Tornillo puente-cuerpo	CK 35	21 Cr Mo V 57	21 Cr Mo V 57	21Cr Mo V 57	A2 70
24	Tuerca puente-cuerpo	C 35	24 Cr Mo 5	24 Cr Mo 5	24 Cr Mo 5	A2 70
25	Tornillo	CK 35	21 Cr Mo V 57	21 Cr Mo V 57	21Cr Mo V 57	A2 70

(*) Otros materiales bajo demanda

FIG. P24 - COMPUERTA PRESSURE SEAL PN100 RF H. EXT. F8

DN	50	65	80	100	125	150	200	250	300	350	400	500	600
L (BW)	300	360	390	450	525	600	750	900	1050	1200	1350	1650	-
V	200	200	250	300	400	400	500	Reductor					
H	500	590	590	600	860	860	1000	1330	1480	-	-	-	-
H1	560	670	700	720	1010	1040	1240	1610	1820	-	-	-	-

FIG. P25 - COMPUERTA PRESSURE SEAL PN160 RF H. EXT. F8

DN	50	65	80	100	125	150	200	250	300	350	400	500	600
L (BW)	300	360	390	450	525	600	750	900	1050	1200	1350	1650	-
V	200	200	250	300	400	400	500	Reductor					
H	500	590	590	600	860	860	1000	1330	1480	-	-	-	-
H1	560	670	700	720	1010	1040	1240	1610	1820	-	-	-	-

FIG. P26 - COMPUERTA PRESSURE SEAL PN250 RF H. EXT. F8

DN	50	65	80	100	125	150	200	250	300	350	400	500	600
L (BW)	300	360	390	450	525	600	750	900	1050	1200	1350	1650	-
V	200	200	250	300	400	400	500	Reductor					
H	500	590	590	600	860	860	1000	1330	1480	-	-	-	-
H1	560	670	700	720	1010	1040	1240	1610	1820	-	-	-	-

FIG. P27 - COMPUERTA PRESSURE SEAL PN320 RF H. EXT. F8

DN	50	65	80	100	125	150	200	250	300	350	400	500	600
L (BW)	300	360	390	450	525	600	750	900	1050	1200	1350	1650	-
V	200	200	250	300	400	400	500	Reductor					
H	500	590	590	600	860	860	1000	1330	1480	-	-	-	-
H1	560	670	700	720	1010	1040	1240	1610	1820	-	-	-	-

FIG. P28 - COMPUERTA PRESSURE SEAL PN420 RF H. EXT. F8

DN	50	65	80	100	125	150	200	250	300	350	400	500	600
L (BW)	300	360	390	450	525	600	750	900	1050	1200	1350	1650	-
V	200	200	250	300	400	400	500	Reductor					
H	500	590	590	600	860	860	1000	1330	1480	-	-	-	-
H1	560	670	700	720	1010	1040	1240	1610	1820	-	-	-	-

DIN EJECUCIONES ESPECIALES

GLOBO TIPO 'Y' PN16/100

Globo Tipo 'Y'		Distancia: F1 / F2
VÁLVULA GLOBO TIPO 'Y' PN16/100 RF		
Materiales		
Cuerpo	Hierro Fundido EN GJL 250	
Asientos	Acero inoxidable 13%Cr	
Husillo	Acero inoxidable 13%Cr	
Empaquetadura	Grafito	
Junta cuerpo-tapa	Ac. inox / Grafito	
Normas		
Bridas	DN15 a DN600 (*) según DIN 2501	
Inspección y Pruebas	DIN 3352 Part 1 y DIN 3230 Part 3	
Distancia entre caras	EN 558-1 (ant. DIN 3202)	
(*) Otras medidas bajo demanda		

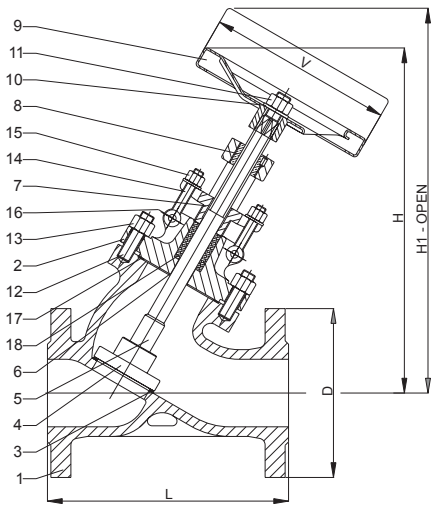
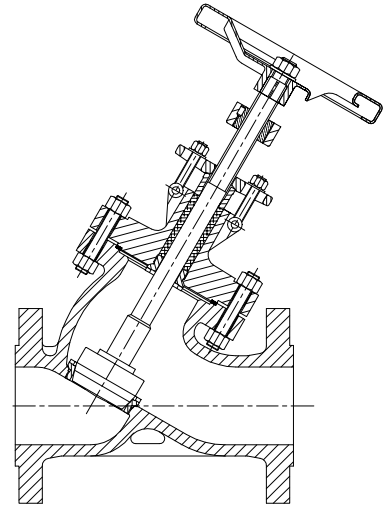

Pos.	Denominación	Componentes		
		Materiales estándar (*)		
1	Cuerpo	EN GJL 250	1.0619	1.4581
2	Tapa	EN GJL 250	1.0619	1.4581
3	Superficie asientos cuerpo	X20 Cr 13	X20 Cr 13	X5 Cr Ni Mo 17 12 2
4	Superficie asientos disco	X20 Cr 13	X20 Cr 13	X5 Cr Ni Mo 17 12 2
5	Husillo	X20 Cr 13	X20 Cr 13	X5 Cr Ni Mo 17 12 2
6	Cierre trasero (integral)	EN GJL 250	1.0619	1.4581
7	Prensaestopas	1.0460	1.0460	X5 Cr Ni Mo 17 12 2
8	Tuerca guía husillo	N/A	Ms 58	Ms 58
9	Volante	Acero	Acero	Acero
10	Pletina	1.0460	1.0460	1.0460
11	Tuerca volante	1.0460	1.0460	X5 Cr Ni Mo 17 12 2
12	Tornillos	CK 35	CK 35	A2 70
13	Tuercas	C 35	C 35	A2 70
14	Tornillos de ojo	CK 35	CK 35	A2 70
15	Tuercas	C 35	C 35	A2 70
16	Pasador tornillo ojo	CK 35	CK 35	A2 70
17	Junta cuerpo-tapa	Ac. inox / Grafito	Ac. inox / Grafito	Ac. inox / Grafito
18	Empaquetadura	Grafito	Grafito	Grafito

(*) Otros materiales bajo demanda

FIG. 1403 - GLOBO TIPO 'Y' HIERRO FUNDIDO/INOX PN16 RF EXT. F1

DN	15	20	25	32	40	50	65	80	100	125	150	175	200	250	300	350	400	450	500	600
L (RF)	130	150	160	180	200	230	290	310	350	400	480	550	600	730	850	980	1100	1200	1250	1450
D	95	105	115	140	150	165	185	200	220	250	285	315	340	405	460	520	580	640	715	840
V	100	100	125	125	150	150	200	200	225	225	300	300	400	500	500	600	600	700	700	800
H	180	190	210	250	290	340	380	450	500	570	650	770	840	950	1100	1250	1500	1650	1850	-
H1	184	195	217	258	300	353	397	470	525	602	688	814	890	1013	1175	1338	1600	1763	1975	-

FIG. 1432 - GLOBO TIPO 'Y' HIERRO FUNDIDO/INOX PN25/40 RF EXT. F1

DN	15	20	25	32	40	50	65	80	100	125	150	175	200	250	300	350	400	450	500	600
L (RF/BW)	130	150	160	180	200	230	290	310	350	400	480	550	600	730	850	980	1100	1200	1250	1450
D (PN25)	95	105	115	140	150	165	185	200	235	270	300	330	360	425	485	555	620	670	730	845
D (PN40)	95	105	115	140	150	165	185	200	235	270	300	350	375	450	515	580	660	685	755	890
V	100	100	125	125	150	150	200	200	225	225	300	300	400	500	500	600	600	700	700	800
H	180	190	210	250	290	340	380	450	500	570	650	770	840	950	1100	1250	1500	1650	1850	-
H1	184	195	217	258	300	353	397	470	525	602	688	814	890	1013	1175	1338	1600	1763	1975	-

FIG. 1560Y - GLOBO TIPO 'Y' HIERRO FUNDIDO/INOX PN63 RF EXT. F2

DN	15	20	25	32	40	50	65	80	100	125	150	175	200	250	300	350	400	500	600
L (RF/BW)	210	230	230	260	260	300	340	380	430	500	550	600	650	775	900	1025	1150	1400	1600
D	105	130	140	155	170	180	205	215	250	295	345	375	415	470	530	600	670	800	930
V	150	150	150	200	200	200	225	250	300	400	500	500	600	700	700	800	800	1000	1200
H	272	338	332	385	422	468	520	603	628	721	819	942	1047	1020	1150	-	-	-	-
H1	276	343	339	393	432	481	537	623	653	753	857	986	1097	1083	1225	-	-	-	-

FIG. 1570Y - GLOBO TIPO 'Y' HIERRO FUNDIDO/INOX PN100 RF EXT. F2

DN	15	20	25	32	40	50	65	80	100	125	150	175	200	250	300
L (RF/BW)	210	230	230	260	260	300	340	380	430	500	550	600	650	775	900
D	105	130	140	155	170	195	220	230	265	315	355	385	430	505	585
V	150	150	150	200	200	200	225	250	300	400	500	500	600	700	700
H	275	341	335	391	430	497	601	668	732	789	860	987	1107	1072	1212
H1	279	346	342	399	440	510	618	688	757	821	898	1031	1157	1135	1287

DIN EJECUCIONES ESPECIALES

GLOBO ANGULAR PN16/100

Globo Angular		Distancia: F32 / F33
VÁLVULA GLOBO ANGULAR PN16/100 RF		
Materiales		
Cuerpo	Hierro Fundido EN GJL 250	
Asientos	Acero inoxidable 13%Cr	
Husillo	Acero inoxidable 13%Cr	
Empaquetadura	Grafito	
Junta cuerpo-tapa	Ac. inox / Grafito	
Normas		
Bridas	DN15 a DN600 (*) según DIN 2501	
Inspección y Pruebas	DIN 3352 Part 1 y DIN 3230 Part 3	
Distancia entre caras	EN 558-1 (ant. DIN 3202)	
(*) Otras medidas bajo demanda		

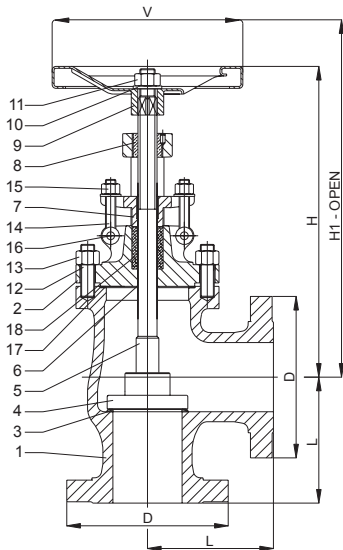
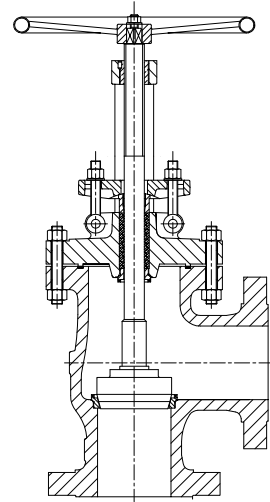

Pos.	Denominación	Componentes		
		Materiales estándar (*)		
1	Cuerpo	EN GJL 250	1.0619	1.4581
2	Tapa	EN GJL 250	1.0619	1.4581
3	Superficie asientos cuerpo	X20 Cr 13	X20 Cr 13	X5 Cr Ni Mo 17 12 2
4	Superficie asientos disco	X20 Cr 13	X20 Cr 13	X5 Cr Ni Mo 17 12 2
5	Husillo	X20 Cr 13	X20 Cr 13	X5 Cr Ni Mo 17 12 2
6	Cierre trasero (integral)	EN GJL 250	1.0619	1.4581
7	Prensaestopas	1.0460	1.0460	X5 Cr Ni Mo 17 12 2
8	Tuerca guía husillo	N/A	Ms 58	Ms 58
9	Volante	Acero	Acero	Acero
10	Pletina	1.0460	1.0460	1.0460
11	Tuerca volante	1.0460	1.0460	X5 Cr Ni Mo 17 12 2
12	Tornillos	CK 35	CK 35	A2 70
13	Tuercas	C 35	C 35	A2 70
14	Tornillos de ojo	CK 35	CK 35	A2 70
15	Tuercas	C 35	C 35	A2 70
16	Pasador tornillo ojo	CK 35	CK 35	A2 70
17	Junta cuerpo-tapa	Ac. inox / Grafito	Ac. inox / Grafito	Ac. inox / Grafito
18	Empaquetadura	Grafito	Grafito	Grafito

(*) Otros materiales bajo demanda

FIG. 1410 - GLOBO ANGULAR HIERRO FUNDIDO/INOX PN16 RF EXT. F32

DN	15	20	25	32	40	50	65	80	100	125	150	175	200	250	300	350	400	450	500	600
L (RF)	90	95	100	105	115	125	145	155	175	200	225	250	275	325	375	425	475	500	575	675
D	95	105	115	140	150	165	185	200	220	250	285	315	340	405	460	520	580	640	715	840
V	100	100	125	125	150	150	200	200	225	225	300	300	400	500	500	600	600	700	700	800
H	160	165	190	200	225	260	280	320	375	415	460	550	570	750	900	1040	1290	1400	1600	-
H1	164	170	197	208	235	273	297	340	400	447	498	594	620	813	975	1128	1390	1513	1725	-

FIG. 1440 - GLOBO ANGULAR HIERRO FUNDIDO/INOX PN25/40 RF EXT. F32

DN	15	20	25	32	40	50	65	80	100	125	150	175	200	250	300	350	400	450	500	600
L (RF/BW)	90	95	100	105	115	125	145	155	175	200	225	250	275	325	375	425	475	500	575	675
D (PN25)	95	105	115	140	150	165	185	200	235	270	300	330	360	425	485	555	620	670	730	845
D (PN40)	95	105	115	140	150	165	185	200	235	270	300	350	375	450	515	580	660	685	755	890
V	100	100	125	125	150	150	200	200	225	225	300	300	400	500	500	600	600	700	700	800
H	160	165	190	200	225	260	280	320	375	415	460	550	570	750	900	1040	1290	1400	1600	-
H1	164	170	197	208	235	273	297	340	400	447	498	594	620	813	975	1128	1390	1513	1725	-

FIG. 1560A - GLOBO ANGULAR HIERRO FUNDIDO/INOX PN63 RF EXT. F33

DN	15	20	25	32	40	50	65	80	100	125	150	175	200	250	300	350	400	500	600
L (RF/BW)	105	105	115	130	130	150	170	190	215	250	275	300	325	390	450	515	575	700	-
D	105	130	140	155	170	180	205	215	250	295	345	375	415	470	530	600	670	800	930
V	150	150	150	200	200	200	225	250	300	400	500	500	600	700	700	800	800	1000	1200
H	250	310	310	330	350	380	410	460	490	550	610	700	750	800	930	-	-	-	-
H1	254	315	317	338	360	393	427	480	515	582	648	744	800	863	1005	-	-	-	-

FIG. 1570A - GLOBO ANGULAR HIERRO FUNDIDO/INOX PN100 RF EXT. F33

DN	15	20	25	32	40	50	65	80	100	125	150	175	200	250	300
L (RF/BW)	105	105	115	130	130	150	170	190	215	250	275	300	325	390	450
D	105	130	140	155	170	195	220	230	265	315	355	385	430	505	585
V	150	150	150	200	200	200	225	250	300	400	500	500	600	700	700
H	250	310	310	330	350	400	480	510	580	600	630	720	780	830	970
H1	254	315	317	338	360	413	497	530	605	632	668	764	830	893	1045

DIN EJECUCIONES ESPECIALES

GLOBO CRIOGÉNICA ACERO INOX PN25/100

Globo Criogénica Acero inoxidable		Distancia: F1 / F2
VÁLVULA GLOBO CRIOGÉNICA ACERO INOXIDABLE PN25/100 RF		
Materiales		
Cuerpo	Acero inoxidable 1.4552	
Asiento (integral)	Acero inoxidable 1.4552	
Obturador	Acero inoxidable	
Husillo	Acero inoxidable	
Empaquetadura	Grafito	
Junta cuerpo-tapa	Ac. inox / Grafito	
Normas		
Bridas	DN15 a DN600 ^(*) según DIN 2501	
Inspección y Pruebas	DIN 3352 Part 1 y DIN 3230 Part 3	
Distancia entre caras	EN 558-1 (ant. DIN 3202)	
^(*) Otras medidas bajo demanda		

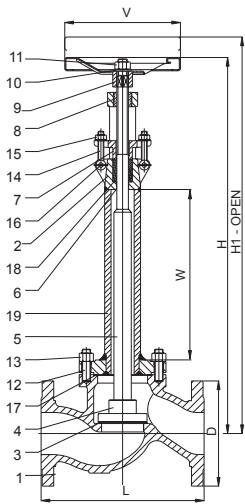
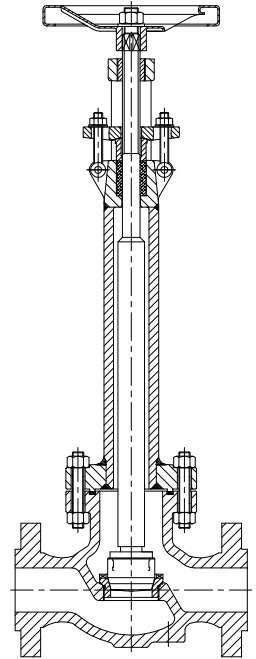

Componentes		
Pos.	Denominación	Material (*)
1	Cuerpo	1.4552
2	Tapa	1.4552
3	Asientos (integrales)	1.4552
4	Obturador	X5 Cr Ni Mo 17 12 2
5	Husillo	X5 Cr Ni Mo 17 12 2
6	Cierre trasero (integral)	1.4552
7	Prensaestopas	X5 Cr Ni Mo 17 12 2
8	Tuerca guía husillo	Ms 58
9	Volante	Acero
10	Pletina	1.0460
11	Tuerca volante	X5 Cr Ni Mo 17 12 2
12	Tornillos	A2 70
13	Tuercas	A2 70
14	Tornillos de ojo	A2 70
15	Tuercas	A2 70
16	Pasador tornillo de ojo	A2 70
17	Junta cuerpo-tapa	Ac. inox / Grafito
18	Empaquetadura	Grafito
19	Extensión	X2 Cr Ni Mo 17 12 2

(*) Otros materiales bajo demanda

FIG. 1430EB - GLOBO CRIOGÉNICA 1.4552/INOX PN25/40 RF H. EXT. F1

DN	15	20	25	32	40	50	65	80	100	125	150	175	200	250	300	350	400	450	500	600
L (RF/BW)	130	150	160	180	200	230	290	310	350	400	480	550	600	730	850	980	1100	1200	1250	1450
D PN25	95	105	115	140	150	165	185	200	235	270	300	330	360	425	485	555	620	670	730	845
D PN40	95	105	115	140	150	165	185	200	235	270	300	350	375	450	515	580	660	685	755	890
V	100	100	125	125	150	150	200	200	225	225	300	300	400	500	500	600	600	700	700	800
W	200	200	200	200	200	200	200	300	300	300	300	300	300	300	300	300	300	300	300	300
H	565	570	595	605	630	665	685	825	880	920	1070	1160	1180	1360	1510	1650	1900	2010	2210	2750
H1	569	575	602	613	640	678	702	845	905	952	1108	1204	1230	1423	1585	1738	2000	2123	2335	-

FIG. 1560EB - GLOBO CRIOGÉNICA 1.4552/INOX PN63 RF H. EXT. F2

DN	15	20	25	32	40	50	65	80	100	125	150	175	200	250	300	350	400	500	600
L (RF/BW)	210	230	230	260	260	300	340	380	430	500	550	600	650	775	900	1025	1150	1400	1600
D	105	130	140	155	170	180	205	215	250	295	345	375	415	470	530	600	670	800	930
V	150	150	150	200	200	200	225	250	300	400	500	500	600	700	700	800	800	1000	1200
W	200	200	200	200	200	200	200	300	300	300	300	300	300	300	300	300	300	300	300
H	655	715	715	735	755	785	815	965	995	1055	1220	1310	1360	1410	1540	-	-	-	-
H1	659	720	722	743	765	798	832	985	1020	1087	1258	1354	1410	1473	1615	-	-	-	-

FIG. 1570EB - GLOBO CRIOGÉNICA 1.4552/INOX PN100 RF H. EXT. F2

DN	15	20	25	32	40	50	65	80	100	125	150	175	200	250	300
L (RF/BW)	210	230	230	260	260	300	340	380	430	500	550	600	650	775	900
D	105	130	140	155	170	195	220	230	265	315	355	385	430	505	585
V	150	150	150	200	200	200	225	250	300	400	500	500	600	700	700
W	200	200	200	200	200	200	200	300	300	300	300	300	300	300	300
H	655	715	715	735	755	805	885	1015	1085	1105	1240	1330	1390	1440	1580
H1	659	720	722	743	765	818	902	1035	1110	1137	1278	1374	1440	1503	1655

DIN EJECUCIONES ESPECIALES

GLOBO CON FUELLE PN16/100

Globo Con Fuelle		Distancia: F1 / F2
VÁLVULA GLOBO CON FUELLE PN16/100 RF		
Materiales		
Cuerpo	Fundición Nodular EN GJS 400 18 LT	
Asiento (integral)	Acero inoxidable 13%Cr	
Fuelle	Acero inoxidable	
Husillo	Acero inoxidable 13%Cr	
Empaquetadura	Grafito	
Junta cuerpo-tapa	Ac. inox / Grafito	
Normas		
Bridas	DN15 a DN600 [□] según DIN 2501	
Inspección y Pruebas	DIN 3352 Part 1 y DIN 3230 Part 3	
Distancia entre caras	EN 558-1 (ant. DIN 3202)	
[□] Otras medidas bajo demanda		

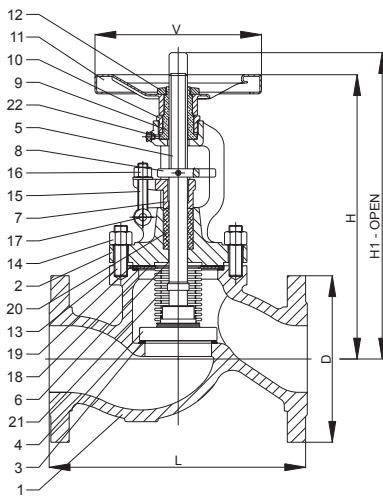
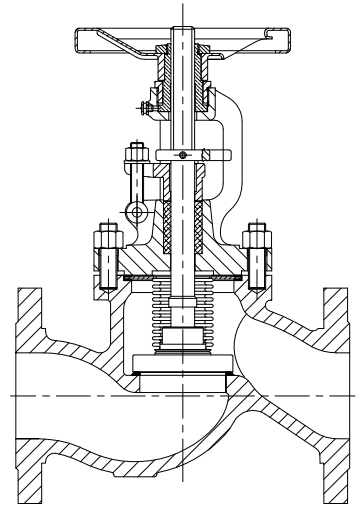

Pos.	Denominación	Componentes		
		EN GJS 400 18 LT	Materiales estándar (*)	
1	Cuerpo	EN GJS 400 18 LT	1.0619	1.4581
2	Tapa	EN GJS 400 18 LT	1.0619	1.4581
3	Superficie asientos cuerpo	X20 Cr 13	X20 Cr 13	1.4581
4	Superficie asientos disco	X20 Cr 13	X20 Cr 13	X5 Cr Ni Mo 17 12 2
5	Husillo	X20 Cr 13	X20 Cr 13	X5 Cr Ni Mo 17 12 2
6	Cierre trasero (integral)	EN GJS 400 18 LT	1.0619	1.4581
7	Prensaestopas	1.0460	1.0460	X5 Cr Ni Mo 17 12 2
8	Dispositivo antirotación	X20 Cr 13	X20 Cr 13	X5 Cr Ni Mo 17 12 2
9	Tuerca guía husillo	N/A	Ms 58	Ms 58
10	Tuerca puente	1.0460	1.0460	X5 Cr Ni Mo 17 12 2
11	Volante	Acero	Acero	Acero
12	Tuerca volante	1.0460	1.0460	X5 Cr Ni Mo 17 12 2
13	Tornillos	CK 35	CK 35	A2 70
14	Tuercas	C 35	C 35	A2 70
15	Tornillos de ojo	CK 35	CK 35	A2 70
16	Tuercas	C 35	C 35	A2 70
17	Pasador tornillo de ojo	CK 35	CK 35	A2 70
18	Brida FUELLE	X6 Cr Ni Ti 18 10	X6 Cr Ni Ti 18 10	X6 Cr Ni Ti 18 10
19	Junta cuerpo-tapa	Ac. inox / Grafito	Ac. inox / Grafito	Ac. inox / Grafito
20	Empaquetadura	Grafito	Grafito	Grafito
21	Fuelle	X6 Cr Ni Ti 18 10	X6 Cr Ni Ti 18 10	X6 Cr Ni Ti 18 10
22	Nipple engrase	Acero	Acero	Acero

(*) Otros materiales bajo demanda

FIG. 1800 - GLOBO FUELLE F.NODULAR/INOX PN16/25 RF H. EXT. F1

DN	15	20	25	32	40	50	65	80	100	125	150	175	200	250	300	350	400	450	500	600
L (RF)	130	150	160	180	200	230	290	310	350	400	480	550	600	730	850	980	1100	1200	1250	1450
D	95	105	115	140	150	165	185	200	220	250	285	315	340	405	460	520	580	640	715	840
V	100	100	125	125	150	150	200	200	225	225	300	300	400	500	500	600	600	700	700	800
H	180	190	210	250	290	340	380	450	500	570	650	770	840	950	1100	1250	1500	1650	1850	-
H1	184	195	217	258	300	353	397	470	525	602	688	814	890	1013	1175	1338	1600	1763	1975	-

FIG. 1670 - GLOBO FUELLE F.NODULAR/INOX PN25/40 RF H. EXT. F1

DN	15	20	25	32	40	50	65	80	100	125	150	175	200	250	300	350	400	450	500	600
L (RF/BW)	130	150	160	180	200	230	290	310	350	400	480	550	600	730	850	980	1100	1200	1250	1450
D (PN25)	95	105	115	140	150	165	185	200	235	270	300	330	360	425	485	555	620	670	730	845
D (PN40)	95	105	115	140	150	165	185	200	235	270	300	350	375	450	515	580	660	685	755	890
V	100	100	125	125	150	150	200	200	225	225	300	300	400	500	500	600	600	700	700	800
H	210	220	220	220	240	270	310	350	400	460	510	600	630	810	950	1100	1350	1460	1660	-
H1	215	225	227	228	250	283	327	370	425	492	548	594	680	813	925	1088	1300	1513	1725	-

FIG. 1560SO - GLOBO FUELLE F.NODULAR/INOX PN63 RF H. EXT. F2

DN	15	20	25	32	40	50	65	80	100	125	150	175	200	250	300	350	400	500	600
L (RF/BW)	210	230	230	260	260	300	340	380	430	500	550	600	650	775	900	1025	1150	1400	1600
D	105	130	140	155	170	180	205	215	250	295	345	375	415	470	530	600	670	800	930
V	150	150	150	200	200	200	225	250	300	400	500	500	600	700	700	800	800	1000	1200
H	300	360	360	380	400	430	460	510	540	610	670	760	810	860	990	-	-	-	-
H1	304	365	367	388	410	443	477	530	565	642	708	804	860	923	1065	-	-	-	-

FIG. 1570SO - GLOBO FUELLE F.NODULAR/INOX PN100 RF H. EXT. F2

DN	15	20	25	32	40	50	65	80	100	125	150	175	200	250	300
L (RF/BW)	210	230	230	260	260	300	340	380	430	500	550	600	650	775	900
D	105	130	140	155	170	195	220	230	265	315	355	385	430	505	585
V	150	150	150	200	200	200	225	250	300	400	500	500	600	700	700
H	300	360	360	380	400	450	530	560	630	660	690	780	840	890	1030
H1	304	365	367	388	410	463	547	580	655	692	728	824	890	953	1105

DIN EJECUCIONES ESPECIALES

GLOBO ANGULAR CON FUELLE PN16/100

Globo Angular Con Fuelle		Distancia: F32 / F33
VÁLVULA GLOBO ANGULAR CON FUELLE PN16/100 RF		
Materiales		
Cuerpo	Fundición Nodular EN GJS 400 18 LT	
Asiento (integral)	Acero inoxidable 13%Cr	
Fuelle	Acero inoxidable	
Husillo	Acero inoxidable 13%Cr	
Empaquetadura	Grafito	
Junta cuerpo-tapa	Ac. inox / Grafito	
Normas		
Bridas	DN15 a DN600 ^(*) según DIN 2501	
Inspección y Pruebas	DIN 3352 Part 1 y DIN 3230 Part 3	
Distancia entre caras	EN 558-1 (ant. DIN 3202)	
^(*) Otras medidas bajo demanda		

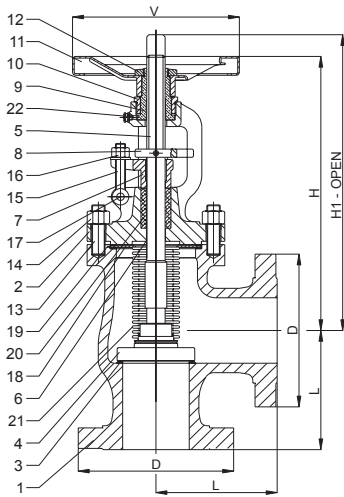
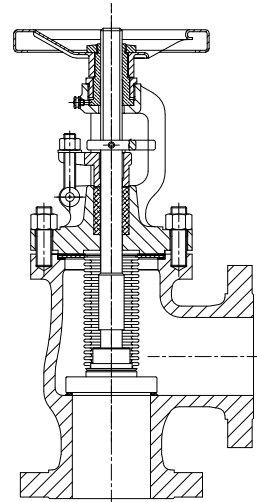

Pos.	Denominación	Componentes		
		Materiales estándar (*)		
1	Cuerpo	EN GJS 400 18 LT	1.0619	1.4581
2	Tapa	EN GJS 400 18 LT	1.0619	1.4581
3	Superficie asientos cuerpo	X20 Cr 13	X20 Cr 13	1.4581
4	Superficie asientos disco	X20 Cr 13	X20 Cr 13	X5 Cr Ni Mo 17 12 2
5	Husillo	X20 Cr 13	X20 Cr 13	X5 Cr Ni Mo 17 12 2
6	Cierre trasero (integral)	EN GJS 400 18 LT	1.0619	1.4581
7	Prensaestopas	1.0460	1.0460	X5 Cr Ni Mo 17 12 2
8	Dispositivo antirotación	X20 Cr 13	X20 Cr 13	X5 Cr Ni Mo 17 12 2
9	Tuerca guía husillo	N/A	Ms 58	Ms 58
10	Tuerca puente	1.0460	1.0460	X5 Cr Ni Mo 17 12 2
11	Volante	Acero	Acero	Acero
12	Tuerca volante	1.0460	1.0460	X5 Cr Ni Mo 17 12 2
13	Tornillos	CK 35	CK 35	A2 70
14	Tuercas	C 35	C 35	A2 70
15	Tornillos de ojo	CK 35	CK 35	A2 70
16	Tuercas	C 35	C 35	A2 70
17	Pasador tornillo de ojo	CK 35	CK 35	A2 70
18	Brida FUELLE	X6 Cr Ni Ti 18 10	X6 Cr Ni Ti 18 10	X6 Cr Ni Ti 18 10
19	Junta cuerpo-tapa	Ac. inox / Grafito	Ac. inox / Grafito	Ac. inox / Grafito
20	Empaquetadura	Grafito	Grafito	Grafito
21	Fuelle	X6 Cr Ni Ti 18 10	X6 Cr Ni Ti 18 10	X6 Cr Ni Ti 18 10
22	Nipple engrase	Acero	Acero	Acero

(*) Otros materiales bajo demanda

FIG. 1810 - GLOBO ANGULAR 90° CON FUELLE F.NODULAR/INOX PN16/25 RF EXT. F32

DN	15	20	25	32	40	50	65	80	100	125	150	175	200	250	300	350	400	450	500	600
L (RF)	90	95	100	105	115	125	145	155	175	200	225	250	275	325	375	425	475	500	575	675
D	95	105	115	140	150	165	185	200	220	250	285	315	340	405	460	520	580	640	715	840
V	100	100	125	125	150	150	200	200	225	225	300	300	400	500	500	600	600	700	700	800
H	180	190	210	250	290	340	380	450	500	570	650	770	840	950	1100	1250	1500	1650	1850	-
H1	184	195	217	258	300	353	397	470	525	602	688	814	890	1013	1175	1338	1600	1763	1975	-

FIG. 1680 - GLOBO ANGULAR 90° CON FUELLE F.NODULAR/INOX PN25/40 RF EXT. F32

DN	15	20	25	32	40	50	65	80	100	125	150	175	200	250	300	350	400	450	500	600
L (RF/BW)	90	95	100	105	115	125	145	155	175	200	225	250	275	325	3775	425	475	500	575	675
D (PN25)	95	105	115	140	150	165	185	200	235	270	300	330	360	425	485	555	620	670	730	845
D (PN40)	95	105	115	140	150	165	185	200	235	270	300	350	375	450	515	580	660	685	755	890
V	100	100	125	125	150	150	200	200	225	225	300	300	400	500	500	600	600	700	700	800
H	210	220	220	220	240	270	310	350	400	460	510	600	630	810	950	1100	1350	1460	1660	-
H1	214	225	227	228	250	283	327	370	425	492	548	594	680	813	925	1088	1300	1513	1725	-

FIG. 1560ASO - GLOBO ANGULAR 90° CON FUELLE F.NODULAR/INOX PN63 RF EXT. F33

DN	15	20	25	32	40	50	65	80	100	125	150	175	200	250	300	350	400	500	600
L (RF/BW)	105	105	115	130	130	150	170	190	215	250	275	300	325	390	450	515	575	700	-
D	105	130	140	155	170	180	205	215	250	295	345	375	415	470	530	600	670	800	930
V	150	150	150	200	200	200	225	250	300	400	500	500	600	700	700	800	800	1000	1200
H	300	360	360	380	400	430	460	510	540	610	670	760	810	860	990	-	-	-	-
H1	304	365	367	388	410	443	477	530	565	642	708	804	860	923	1065	-	-	-	-

FIG. 1570ASO - GLOBO ANGULAR 90° CON FUELLE F.NODULAR/INOX PN100 RF EXT. F33

DN	15	20	25	32	40	50	65	80	100	125	150	175	200	250	300
L (RF/BW)	105	105	115	130	130	150	170	190	215	250	275	300	325	390	450
D	105	130	140	155	170	195	220	230	265	315	355	385	430	505	585
V	150	150	150	200	200	200	225	250	300	400	500	500	600	700	700
H	300	360	360	380	400	450	530	560	630	660	690	780	840	890	1030
H1	304	365	367	388	410	463	547	580	655	692	728	824	890	953	1105

DIN EJECUCIONES ESPECIALES

GLOBO TIPO 'Y' CON FUELLE PN25/100

Globo Tipo 'Y' Con Fuelle		Distancia: F1 / F2
VÁLVULA GLOBO TIPO 'Y' CON FUELLE PN25/100 RF		
Materiales		
Cuerpo	Acero carbono 1.0619	
Asiento (integral)	Acero inoxidable 13%Cr	
Fuelle	Acero inoxidable	
Husillo	Acero inoxidable 13%Cr	
Empaquetadura	Grafito	
Junta cuerpo-tapa	Ac. inox / Grafito	
Normas		
Bridas	DN15 a DN600 ^(*) según DIN 2501	
Inspección y Pruebas	DIN 3352 Part 1 y DIN 3230 Part 3	
Distancia entre caras	EN 558-1 (ant. DIN 3202)	
^(*) Otras medidas bajo demanda		

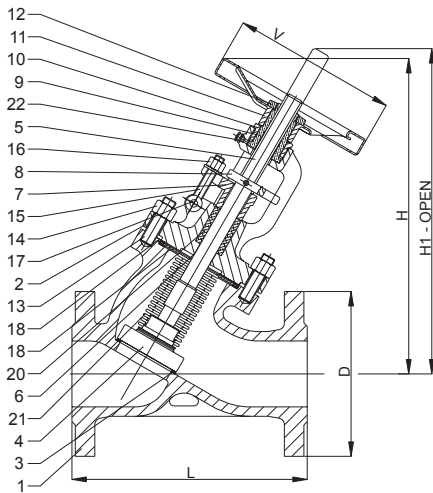
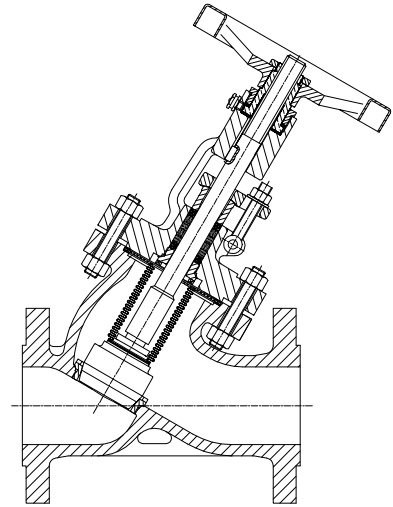

Pos.	Denominación	Componentes	
		Materiales estándar (*)	
1	Cuerpo	1.0619	1.4581
2	Tapa	1.0619	1.4581
3	Superficie asientos cuerpo	X20 Cr 13	X5 Cr Ni Mo 17 12 2
4	Superficie asientos disco	X20 Cr 13	X5 Cr Ni Mo 17 12 2
5	Husillo	X20 Cr 13	X5 Cr Ni Mo 17 12 2
6	Cierre trasero (integral)	1.0619	1.4581
7	Prensaestopas	1.0460	X5 Cr Ni Mo 17 12 2
8	Dispositivo antirotación	X20 Cr 13	X5 Cr Ni Mo 17 12 2
9	Tuerca guía husillo	Ms 58	Ms 58
10	Tuerca puente	1.0460	X5 Cr Ni Mo 17 12 2
11	Volante	Acero	Acero
12	Tuerca volante	1.0460	X5 Cr Ni Mo 17 12 2
13	Tornillos	CK 35	A2 70
14	Tuercas	C 35	A2 70
15	Tornillos de ojo	CK 35	A2 70
16	Tuercas	C 35	A2 70
17	Pasador tornillo de ojo	CK 35	A2 70
18	Brida FUELLE	X6 Cr Ni Ti 18 10	X6 Cr Ni Ti 18 10
19	Junta cuerpo-tapa	Ac. inox / Grafito	Ac. inox / Grafito
20	Empaquetadura	Grafito	Grafito
21	Fuelle	X6 Cr Ni Ti 18 10	X6 Cr Ni Ti 18 10
22	Nipple engrase	Acero	Acero

(*) Otros materiales bajo demanda

FIG. 1432SO - GLOBO 'Y' CON FUELLE ACERO CARBONO/INOX PN25/40 RF EXT. F1

DN	15	20	25	32	40	50	65	80	100	125	150	175	200	250	300	350	400	450	500	600
L (RF/BW)	130	150	160	180	200	230	290	310	350	400	480	550	600	730	850	980	1100	1200	1250	1450
D (PN25)	95	105	115	140	150	165	185	200	235	270	300	330	360	425	485	555	620	670	730	845
D (PN40)	95	105	115	140	150	165	185	200	235	270	300	350	375	450	515	580	660	685	755	890
V	100	100	125	125	150	150	200	200	225	225	300	300	400	500	500	600	600	700	700	800
H	230	240	260	300	340	390	430	500	550	630	710	830	900	1010	1160	1310	1560	1710	1910	-
H1	234	245	267	308	350	403	447	520	575	662	748	874	950	1073	1235	1398	1660	1823	2035	-

FIG. 1560YSO - GLOBO 'Y' CON FUELLE ACERO CARBONO/INOX PN63 RF EXT. F2

DN	15	20	25	32	40	50	65	80	100	125	150	175	200	250	300	350	400	500	600
L (RF/BW)	210	230	230	260	260	300	340	380	430	500	550	600	650	775	900	1025	1150	1400	1600
D	105	130	140	155	170	180	205	215	250	295	345	375	415	470	530	600	670	800	930
V	150	150	150	200	200	200	225	250	300	400	500	500	600	700	700	800	800	1000	1200
H	322	388	382	435	472	518	570	653	678	781	879	1002	1107	1080	1210	-	-	-	-
H1	326	393	389	443	482	531	587	673	703	813	917	1046	1157	1143	1285	-	-	-	-

FIG. 1570YSO - GLOBO 'Y' CON FUELLE ACERO CARBONO/INOX PN100 RF EXT. F2

DN	15	20	25	32	40	50	65	80	100	125	150	175	200	250	300
L (RF/BW)	210	230	230	260	260	300	340	380	430	500	550	600	650	775	900
D	105	130	140	155	170	195	220	230	265	315	355	385	430	505	585
V	150	150	150	200	200	200	225	250	300	400	500	500	600	700	700
H	325	391	385	441	480	547	651	718	782	849	920	1047	1167	1132	1272
H1	329	396	392	449	490	560	668	738	807	881	958	1091	1217	1195	1347

DIN EJECUCIONES ESPECIALES

GLOBO PRESSURE SEAL PN 100/420

Globo Pressure Seal Acero Fig. P16x		Distancia: F8
VÁLVULA GLOBO PRESSURE SEAL ACERO PN100/420 RF		
Materiales estándar		
Cuerpo	Acero carbono	
Asiento	Acero	
Obturador	Acero inoxidable	
Husillo	Acero inoxidable 13% Cr	
Empaquetadura	Grafito	
Junta cuerpo-tapa	Ac. inox / Grafito	
Normas		
BW	DN50 a DN600 (*) según DIN 3239	
Inspección y Pruebas	DIN 3352 Part 1 y DIN 3230 Part 3	
Distancia entre caras	EN 558-1 Serie 99 (ant. DIN 3202 F8)	
(*) Otras medidas bajo demanda		

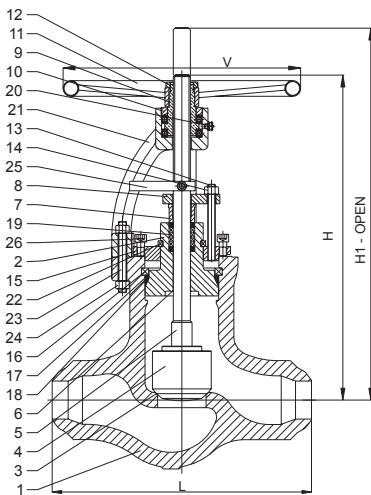
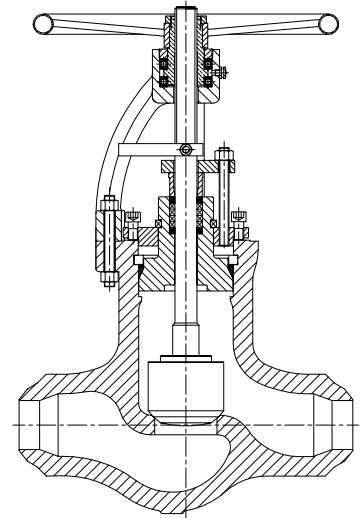

Pos.	Denominación	Componentes		
		Materiales estándar (*)		
1	Cuerpo	1.0619	1.7357	1.7380
2	Tapa	1.0619	1.7357	1.7380
3	Superficie asientos cuerpo	1.0160 +HF	1.0460 +HF	1.0460 +HF
4	Superficie asientos cuña	1.0619 +HF	1.7357 +HF	1.7380 +HF
5	Husillo	X20 Cr 13	X20 Cr 13	X20 Cr 13
6	Cierre trasero (integral)		Stellite	
7	Prensaestopas	X20 Cr 13	X20 Cr 13	X20 Cr 13
8	Brida prensaestopas	1.0460	X20 Cr 13	X20 Cr 13
9	Tuerca guía husillo		GGG50	
10	Tuerca puente	1.0460	1.0460	1.0460
11	Volante		Acero	
12	Tuerca volante		1.0460	
13	Tornillos	CK 35	21Cr Mo V 57	21 Cr Mo V 57
14	Tuercas	C 35	24 Cr Mo 5	24 Cr Mo 5
15	Brida retén	1.0460	1.0460	1.0460
16	Anillo retén	X20 Cr 13	X20 Cr 13	X20 Cr 13
17	Anillo espaciador	X20 Cr 13	X20 Cr 13	X20 Cr 13
18	Junta cuerpo-tapa		Ac. inox / Grafito	
19	Empaquetadura		Grafito	
20	Nipple engrase		Acero	
21	Puente	1.0619	1.7357	1.7380
22	Anillo soporte	1.0460	X20 Cr 13	X20 Cr 13
23	Tornillo puente-cuerpo	CK 35	21 Cr Mo V 57	21 Cr Mo V 57
24	Tuerca puente-cuerpo	C 35	24 Cr Mo 5	24 Cr Mo 5
25	Dispositivo antirotación	C 35	21 Cr Mo V 57	21 Cr Mo V 57
26	Tornillo	CK 35	21 Cr Mo V 57	21 Cr Mo V 57

(*) Otros materiales bajo demanda

FIG. P162 - GLOBO PRESSURE SEAL PN100 RF H. EXT. F8

DN	50	65	80	100	125	150	200	250	300	350	400	500	600
L (BW)	300	360	390	450	525	600	750	900	1050	1200	1350	1650	-
V	200	200	250	300	400			Reductor					-
H	500	590	590	600	860	860	1000	1330	1480	-	-	-	-
H1	513	607	610	625	892	898	1050	1393	1555	-	-	-	-

FIG. P163 - GLOBO PRESSURE SEAL PN160 RF H. EXT. F8

DN	50	65	80	100	125	150	200	250	300	350	400	500	600
L (BW)	300	360	390	450	525	600	750	900	1050	1200	1350	1650	-
V	250	300	300	400	500	Reductor							-
H	500	590	590	600	860	860	1000	1330	1480	-	-	-	-
H1	513	607	610	625	892	898	1050	1393	1555	-	-	-	-

FIG. P164 - GLOBO PRESSURE SEAL PN250 RF H. EXT. F8

DN	50	65	80	100	125	150	200	250	300	350	400	500	600
L (BW)	300	360	390	450	525	600	750	900	1050	1200	1350	1650	-
V	300	400	400	Reductor							-		
H	500	590	590	600	860	860	1000	1330	1480	-	-	-	-
H1	513	607	610	625	892	898	1050	1393	1555	-	-	-	-

FIG. P165 - GLOBO PRESSURE SEAL PN320 RF H. EXT. F8

DN	50	65	80	100	125	150	200	250	300	350	400	500	600
L (BW)	300	360	390	450	525	600	750	900	1050	1200	1350	1650	-
V	300	400	400	Reductor							-		
H	500	590	590	600	860	860	1000	1330	1480	-	-	-	-
H1	513	607	610	625	892	898	1050	1393	1555	-	-	-	-

FIG. P166 - GLOBO PRESSURE SEAL PN420 RF H. EXT. F8

DN	50	65	80	100	125	150	200	250	300	350	400	500	600
L (BW)	300	360	390	450	525	600	750	900	1050	1200	1350	1650	-
V	300	400	400	Reductor							-		
H	500	590	590	600	860	860	1000	1330	1480	-	-	-	-
H1	513	607	610	625	892	898	1050	1393	1555	-	-	-	-

DIN EJECUCIONES ESPECIALES

GLOBO PRESSURE SEAL TIPO 'Y' PN 100/420

Globo Pressure Seal Tipo 'Y' Acero Fig. P18x		Distancia: F8
VÁLVULA GLOBO PRESSURE SEAL 'Y' ACERO PN100/420 RF		
Materiales estándar		
Cuerpo	Acero carbono	
Asiento	Acero	
Obturador	Acero inoxidable	
Husillo	Acero inoxidable 13% Cr	
Empaquetadura	Grafito	
Junta cuerpo-tapa	Ac. inox / Grafito	
Normas		
BW	DN50 a DN600 (*) según DIN 3239	
Inspección y Pruebas	DIN 3352 Part 1 y DIN 3230 Part 3	
Distancia entre caras	EN 558-1 Serie 99 (ant. DIN 3202 F8)	
(*) Otras medidas bajo demanda		

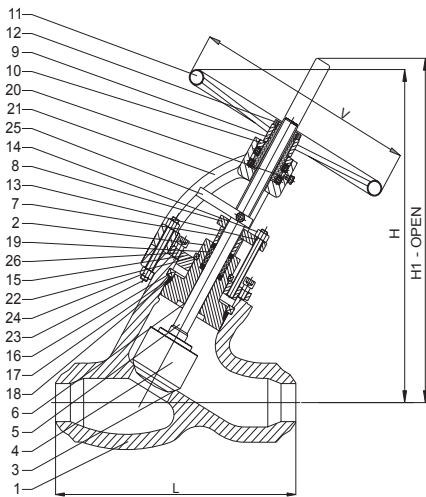
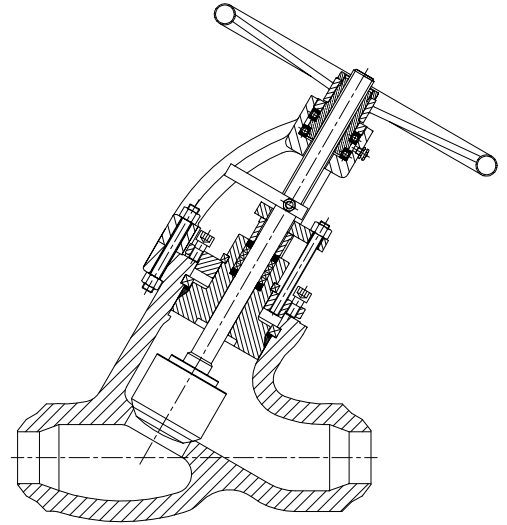

Componentes				
Pos.	Denominación	Materiales estándar (*)		
1	Cuerpo	1.0619	1.7357	1.7380
2	Tapa	1.0619	1.7357	1.7380
3	Superficie asientos cuerpo	1.0460 +HF	1.0460 +HF	1.0460 +HF
4	Superficie asientos cuña	1.0619 +HF	1.7357 +HF	1.7380 +HF
5	Husillo	X20 Cr 13	X20 Cr 13	X20 Cr 13
6	Cierre trasero (integral)		Stellite	
7	Prensaestopas	X20 Cr 13	X20 Cr 13	X20 Cr 13
8	Brida prensaestopas	1.0460	X20 Cr 13	X20 Cr 13
9	Tuerca guía husillo		GGG50	
10	Tuerca puente	1.0460	1.0460	1.0460
11	Volante		Acero	
12	Tuerca volante		1.0460	
13	Tornillos	CK 35	21Cr Mo V 57	21 Cr Mo V 57
14	Tuercas	C 35	24 Cr Mo 5	24 Cr Mo 5
15	Brida retén	1.0460	1.0460	1.0460
16	Anillo retén	X20 Cr 13	X20 Cr 13	X20 Cr 13
17	Anillo espaciador	X20 Cr 13	X20 Cr 13	X20 Cr 13
18	Junta cuerpo-tapa		Ac. inox / Grafito	
19	Empaquetadura		Grafito	
20	Nipple engrase		Acero	
21	Puente	1.0619	1.7357	1.7380
22	Anillo soporte	1.0460	1.0460	1.0460
23	Tornillo puente-cuerpo	CK 35	21 Cr Mo V 57	21 Cr Mo V 57
24	Tuerca puente-cuerpo	C 35	24 Cr Mo 5	24 Cr Mo 5
25	Dispositivo antirotación	C 35	21 Cr Mo V 57	21 Cr Mo V 57
26	Tornillo	CK 35	21 Cr Mo V 57	21 Cr Mo V 57

(*) Otros materiales bajo demanda

FIG. P182 - GLOBO PRESSURE SEAL 'Y' PN100 RF H. EXT. F8

DN	50	65	80	100	125	150	200	250	300	350	400	500	600
L (BW)	300	360	390	450	525	600	750	900	1050	1200	1350	1650	-
V	200	200	250	300	400				Reductor				-
H	500	590	590	600	860	860	1000	1330	1480	-	-	-	-
H1	513	607	610	625	892	898	1050	1393	1555	-	-	-	-

FIG. P183 - GLOBO PRESSURE SEAL 'Y' PN160 RF H. EXT. F8

DN	50	65	80	100	125	150	200	250	300	350	400	500	600
L (BW)	300	360	390	450	525	600	750	900	1050	1200	1350	1650	-
V	250	300	300	400	500	Reductor							-
H	500	590	590	600	860	860	1000	1330	1480	-	-	-	-
H1	513	607	610	625	892	898	1050	1393	1555	-	-	-	-

FIG. P184 - GLOBO PRESSURE SEAL 'Y' PN125 RF H. EXT. F8

DN	50	65	80	100	125	150	200	250	300	350	400	500	600
L (BW)	300	360	390	450	525	600	750	900	1050	1200	1350	1650	-
V	300	400	400	Reductor							-		
H	500	590	590	600	860	860	1000	1330	1480	-	-	-	-
H1	513	607	610	625	892	898	1050	1393	1555	-	-	-	-

FIG. P185 - GLOBO PRESSURE SEAL 'Y' PN320 RF H. EXT. F8

DN	50	65	80	100	125	150	200	250	300	350	400	500	600
L (BW)	300	360	390	450	525	600	750	900	1050	1200	1350	1650	-
V	300	400	400	Reductor							-		
H	500	590	590	600	860	860	1000	1330	1480	-	-	-	-
H1	513	607	610	625	892	898	1050	1393	1555	-	-	-	-

FIG. P186 - GLOBO PRESSURE SEAL 'Y' PN420 RF H. EXT. F8

DN	50	65	80	100	125	150	200	250	300	350	400	500	600
L (BW)	300	360	390	450	525	600	750	900	1050	1200	1350	1650	-
V	300	400	400	Reductor							-		
H	500	590	590	600	860	860	1000	1330	1480	-	-	-	-
H1	513	607	610	625	892	898	1050	1393	1555	-	-	-	-

DIN EJECUCIONES ESPECIALES

RETENCIÓN PISTÓN PN16/160

Retención Pistón		Distancia: F1 / F2
VÁLVULA RETENCIÓN A PISTÓN PN16/160 RF		
Materiales		
Cuerpo	Hierro Fundido EN G.JL 250	
Asiento	Acero inoxidable 13%Cr	
Muelle	Acero inoxidable	
Junta cuerpo-tapa	Ac. inox / Grafito	
Normas		
Bridas	DN15 a DN600 (*) según DIN 2501	
Inspección y Pruebas	DIN 3352 Part 1 y DIN 3230 Part 3	
Distancia entre caras	EN 558-1 (ant. DIN 3202)	
(*) Otras medidas bajo demanda		

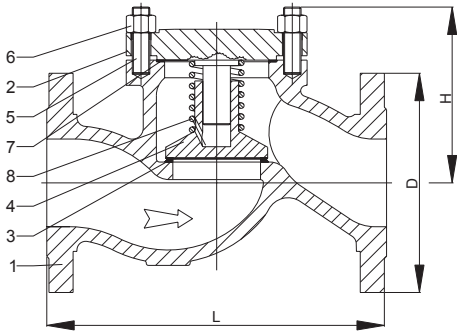
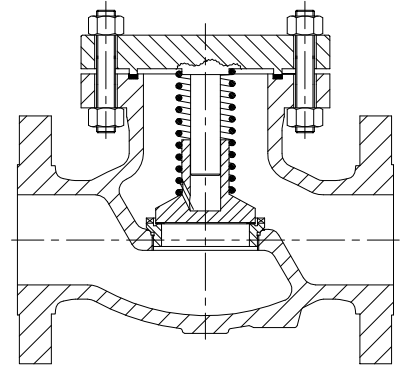

Pos.	Denominación	Componentes		
		Materiales estándar (*)		
1	Cuerpo	EN G.JL 250	1.0619	1.4581
2	Tapa	EN G.JL 250	1.0619	1.4581
3	Superficie asientos cuerpo	N/A	X20 Cr 13	X5 Cr Ni Mo 17 12 2
4	Superficie asientos disco	X20 Cr 13	X20 Cr 13	X5 Cr Ni Mo 17 12 2
5	Muelle	X5 Cr Ni Mo 17 12 2	X5 Cr Ni Mo 17 12 2	X5 Cr Ni Mo 17 12 2
6	Tornillos	CK 35	CK 35	A2 70
7	Tuercas	C 35	C 35	A2 70
8	Junta cuerpo-tapa	Ac. inox / Grafito	Ac. inox / Grafito	Ac. inox / Grafito

(*) Otros materiales bajo demanda

FIG. 1402 - RETENCIÓN PISTÓN HIERRO FUNDIDO/INOX PN16 RF F1

DN	15	20	25	32	40	50	65	80	100	125	150	175	200	250	300	350	400	450	500	600
L (RF)	130	150	160	180	200	230	290	310	350	400	480	550	600	730	850	980	1100	1200	1250	1450
D	95	105	115	140	150	165	185	200	220	250	285	315	340	405	460	520	580	640	715	840
H	70	80	85	100	110	115	130	145	165	185	205	235	250	300	360	410	460	520	570	-

FIG. 1431 - RETENCIÓN PISTÓN HIERRO FUNDIDO/INOX PN25/40 RF F1

DN	15	20	25	32	40	50	65	80	100	125	150	175	200	250	300	350	400	450	500	600
L (RF/BW)	130	150	160	180	200	230	290	310	350	400	480	550	600	730	850	980	1100	1200	1250	1450
D (PN25)	95	105	115	140	150	165	185	200	235	270	300	330	360	425	485	555	620	670	730	845
D (PN40)	95	105	115	140	150	165	185	200	235	270	300	350	375	450	515	580	660	685	755	890
H	65	75	85	100	110	125	145	160	190	220	250	295	320	385	450	510	585	610	670	-

FIG. 1560R - RETENCIÓN PISTÓN HIERRO FUNDIDO/INOX PN63 RF F2

DN	15	20	25	32	40	50	65	80	100	125	150	175	200	250	300	350	400	500	600
L (RF/BW)	210	230	230	260	260	300	340	380	430	500	550	600	650	775	900	1025	1150	1400	1600
D	105	130	140	155	170	180	205	215	250	295	345	375	415	470	530	600	670	800	930
H	105	120	120	135	150	160	180	200	230	280	310	340	390	430	500	-	-	-	-

FIG. 1570R - RETENCIÓN PISTÓN HIERRO FUNDIDO/INOX PN100 RF F2

DN	15	20	25	32	40	50	65	80	100	125	150	175	200	250	300
L (RF/BW)	210	230	230	260	260	300	340	380	430	500	550	600	650	775	900
D	105	130	140	155	170	195	220	230	265	315	355	385	430	505	585
H	105	120	120	135	150	170	200	220	250	300	350	380	410	480	570

FIG. 1580R - RETENCIÓN PISTÓN HIERRO FUNDIDO/INOX PN160 RF F2

DN	15	20	25	32	40	50	65	80	100	125	150	175	200	250	300
L (RF/BW)	210	230	230	260	260	300	340	380	430	500	550	600	650	775	900
D	105	130	140	155	170	195	220	230	265	315	355	385	430	505	585
H	110	125	125	140	155	180	220	240	270	320	370	400	430	500	600

DIN EJECUCIONES ESPECIALES

RETENCIÓN PISTÓN EN 'Y' PN16/100

Retención Pistón en 'Y'		Distancia: F1 / F2
VÁLVULA RETENCIÓN A PISTÓN EN 'Y' PN16/100 RF		
Materiales		
Cuerpo	Hierro Fundido EN GJL 250	
Asiento	Acero inoxidable 13%Cr	
Muelle	Acero inoxidable	
Junta cuerpo-tapa	Ac. inox / Grafito	
Normas		
Bridas	DN15 a DN600 ^(*) según DIN 2501	
Inspección y Pruebas	DIN 3352 Part 1 y DIN 3230 Part 3	
Distancia entre caras	EN 558-1 (ant. DIN 3202)	
^(*) Otras medidas bajo demanda		

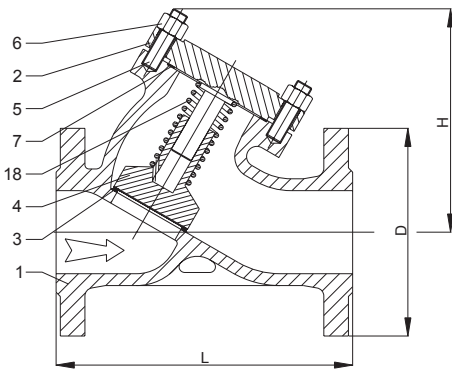
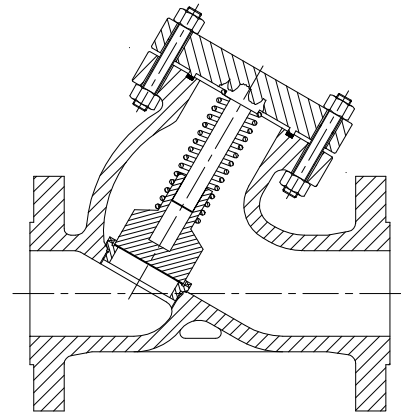

Pos.	Denominación	Componentes		
		Materiales estándar (*)		
1	Cuerpo	EN GJL 250	1.0619	1.4581
2	Tapa	EN GJL 250	1.0619	1.4581
3	Superficie asientos cuerpo	N/A	X20 Cr 13	X5 Cr Ni Mo 17 12 2
4	Superficie asientos disco	X20 Cr 13	X20 Cr 13	X5 Cr Ni Mo 17 12 2
5	Muelle	X5 Cr Ni Mo 17 12 2	X5 Cr Ni Mo 17 12 2	X5 Cr Ni Mo 17 12 2
6	Tornillos	CK 35	CK 35	A2 70
7	Tuercas	C 35	C 35	A2 70
8	Junta cuerpo-tapa	Ac. inox / Grafito	Ac. inox / Grafito	Ac. inox / Grafito

(*) Otros materiales bajo demanda

FIG. 1405 - RETENCIÓN PISTÓN EN 'Y' HIERRO FUNDIDO/INOX PN16 RF F1

DN	15	20	25	32	40	50	65	80	100	125	150	175	200	250	300	350	400	450	500	600
L (RF)	130	150	160	180	200	230	290	310	350	400	480	550	600	730	850	980	1100	1200	1250	1450
D	95	105	115	140	150	165	185	200	220	250	285	315	340	405	460	520	580	640	715	840
H	70	80	85	100	110	115	130	145	165	185	205	235	250	300	360	410	460	520	570	-

FIG. 1434 - RETENCIÓN PISTÓN EN 'Y' HIERRO FUNDIDO/INOX PN25/40 RF F1

DN	15	20	25	32	40	50	65	80	100	125	150	175	200	250	300	350	400	450	500	600
L (RF/BW)	130	150	160	180	200	230	290	310	350	400	480	550	600	730	850	980	1100	1200	1250	1450
D (PN25)	95	105	115	140	150	165	185	200	235	270	300	330	360	425	485	555	620	670	730	845
D (PN40)	95	105	115	140	150	165	185	200	235	270	300	350	375	450	515	580	660	685	755	890
H	65	75	85	100	110	125	145	160	190	220	250	295	320	385	450	510	585	610	670	-

FIG. 1560YR - RETENCIÓN PISTÓN EN 'Y' HIERRO FUNDIDO/INOX PN63 RF F2

DN	15	20	25	32	40	50	65	80	100	125	150	175	200	250	300	350	400	500	600
L (RF/BW)	210	230	230	260	260	300	340	380	430	500	550	600	650	775	900	1025	1150	1400	1600
D	105	130	140	155	170	180	205	215	250	295	345	375	415	470	530	600	670	800	930
H	105	120	120	135	150	160	180	200	230	280	310	340	390	430	500	-	-	-	-

FIG. 1570YR - RETENCIÓN PISTÓN EN 'Y' HIERRO FUNDIDO/INOX PN100 RF F2

DN	15	20	25	32	40	50	65	80	100	125	150	175	200	250	300
L (RF/BW)	210	230	230	260	260	300	340	380	430	500	550	600	650	775	900
D	105	130	140	155	170	195	220	230	265	315	355	385	430	505	585
H	105	120	120	135	150	170	200	220	250	300	350	380	410	480	570

DIN EJECUCIONES ESPECIALES

RETENCIÓN PISTON ANGULAR PN16/100

Retención Pistón Angular		Distancia: F32 / F33
VÁLVULA RETENCIÓN A PISTÓN ANGULAR PN16/100 RF		
Materiales		
Cuerpo	Hierro Fundido EN G.JL 250	
Asiento	Acero inoxidable 13%Cr	
Muelle	Acero inoxidable	
Junta cuerpo-tapa	Ac. inox / Grafito	
Normas		
Bridas	DN15 a DN600 ^(*) según DIN 2501	
Inspección y Pruebas	DIN 3352 Part 1 y DIN 3230 Part 3	
Distancia entre caras	EN 558-1 (ant. DIN 3202)	
^(*) Otras medidas bajo demanda		

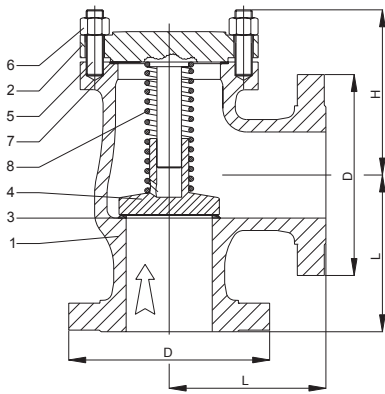
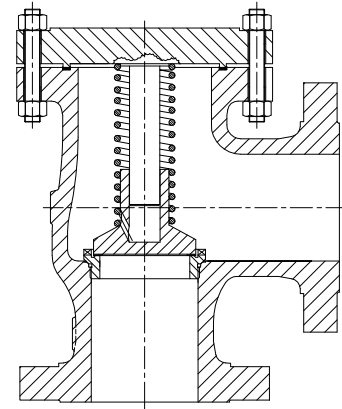

Pos.	Denominación	Componentes		
		Materiales estándar (*)		
1	Cuerpo	EN G.JL 250	1.0619	1.4581
2	Tapa	EN G.JL 250	1.0619	1.4581
3	Superficie asientos cuerpo	N/A	X20 Cr 13	X5 Cr Ni Mo 17 12 2
4	Superficie asientos disco	X20 Cr 13	X20 Cr 13	X5 Cr Ni Mo 17 12 2
5	Muelle	X5 Cr Ni Mo 17 12 2	X5 Cr Ni Mo 17 12 2	X5 Cr Ni Mo 17 12 2
6	Tornillos	CK 35	CK 35	A2 70
7	Tuercas	C 35	C 35	A2 70
8	Junta cuerpo-tapa	Ac. inox / Grafito	Ac. inox / Grafito	Ac. inox / Grafito

(*) Otros materiales bajo demanda

FIG. 1411 - RETENCIÓN PISTÓN ANGULAR HIERRO FUNDIDO/INOX PN16 RF F32

DN	15	20	25	32	40	50	65	80	100	125	150	175	200	250	300	350	400	450	500	600
L (RF)	90	95	100	105	115	125	145	155	175	200	225	250	275	325	375	425	475	500	575	675
D	95	105	115	140	150	165	185	200	220	250	285	315	340	405	460	520	580	640	715	840
H	70	80	85	100	110	115	130	145	165	185	205	235	250	300	360	410	460	520	570	-

FIG. 1441 - RETENCIÓN PISTÓN ANGULAR HIERRO FUNDIDO/INOX PN25/40 RF F32

DN	15	20	25	32	40	50	65	80	100	125	150	175	200	250	300	350	400	450	500	600
L (RF/BW)	90	95	100	105	115	125	145	155	175	200	225	250	275	325	375	425	475	500	575	675
D (PN25)	95	105	115	140	150	165	185	200	235	270	300	330	360	425	485	555	620	670	730	845
D (PN40)	95	105	115	140	150	165	185	200	235	270	300	350	375	450	515	580	660	685	755	890
H	70	80	85	100	110	125	145	160	190	220	250	295	320	385	450	510	585	610	670	-

FIG. 1560AR - RETENCIÓN PISTÓN ANGULAR HIERRO FUNDIDO/INOX PN63 RF F33

DN	15	20	25	32	40	50	65	80	100	125	150	175	200	250	300	350	400	500	600
L (RF/BW)	105	105	115	130	130	150	170	190	215	250	275	300	325	390	450	515	575	700	-
D	105	130	140	155	170	180	205	215	250	295	345	375	415	470	530	600	670	800	-
H	105	120	120	135	150	160	180	200	230	280	310	340	390	430	500	-	-	-	-

FIG. 1570AR - RETENCIÓN PISTÓN ANGULAR HIERRO FUNDIDO/INOX PN100 RF F33

DN	15	20	25	32	40	50	65	80	100	125	150	175	200	250	300
L (RF/BW)	105	105	115	130	130	150	170	190	215	250	275	300	325	390	450
D	105	130	140	155	170	195	220	230	265	315	355	385	430	505	585
H	105	120	120	135	150	170	200	220	250	300	350	380	410	480	570

DIN EJECUCIONES ESPECIALES

RETENCIÓN CLAPETA PRESSURE SEAL PN100/420

Retención Clapeta Pressure Seal Fig. P17x		Distancia: F2 / F9
VÁLVULA RETENCIÓN A CLAPETA PRESSURE SEAL PN100/420 RF		
Materiales		
Cuerpo	Acero carbono 1.0619	
Asiento	Acero carbono + HF	
Obturador	Acero carbono + HF	
Junta cuerpo-tapa	Ac. inox / Grafito	
Normas		
Bridas	DN50 a DN600 (*) según DIN 2501	
Inspección y Pruebas	DIN 3352 Part 1 y DIN 3230 Part 3	
Distancia entre caras	EN 558-1 (ant. DIN 3202)	
(*) Otras medidas bajo demanda		

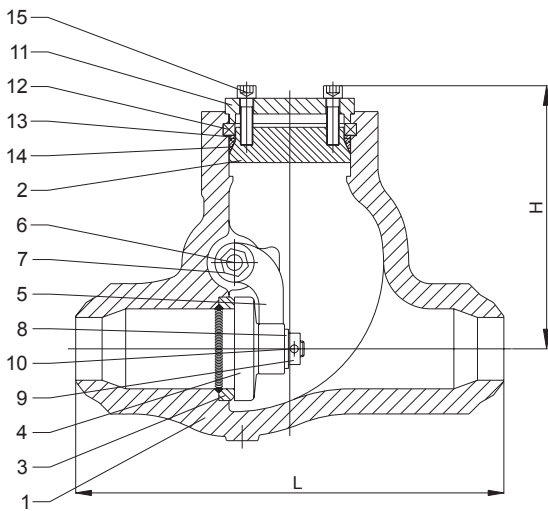
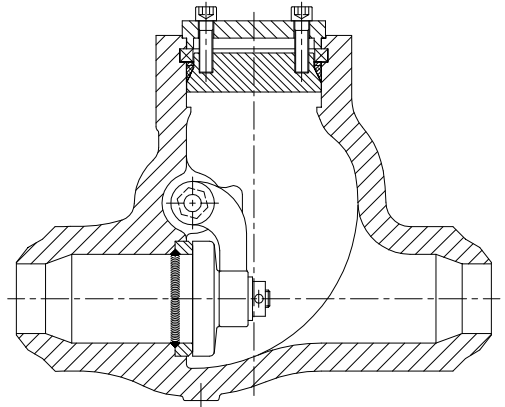

Componentes			
Pos.	Denominación	Materiales estándar (*)	
1	Cuerpo	1.0619	1.4581
2	Tapa	1.0619	1.4581
3	Superficie asientos cuerpo	1.0460 +HF	X2 Cr Ni Mo 17 12 2 +HF
4	Superficie asientos clapeta	1.0619 +HF	1.4581 +HF
5	Biela	1.0619	1.4581
6	Pasador	X20 Cr 13	X5 Cr Ni Mo 17 12 2
7	Macho	1.0460	X5 Cr Ni Mo 17 12 2
8	Pletina	1.0460	X5 Cr Ni Mo 17 12 2
9	Tuerca	C 35	A2 70
10	Pasador	X5 Cr Ni Mo 17 12 2	X5 Cr Ni Mo 17 12 2
11	Brida retén	1.0460	1.4401
12	Anillo retén segmentado	X20 Cr 13	1.4401
13	Anillo espaciador	X20 Cr 13	1.4401
14	Junta cuerpo-tapa	Ac. inox / Grafito	Ac. inox / Grafito
15	Tornillo	CK 35	A2 70

(*) Otros materiales bajo demanda

FIG. P172 - RETENCIÓN A CLAPETA PRESSURE SEAL ACERO CARBONO/INOX PN100 RF F2

DN	50	65	80	100	125	150	200	250	300	350	400	500	600
L (BW)	300	340	380	430	500	550	650	775	900	1025	1150	1275	1600
L (RF)	300	340	380	430	500	550	650	775	900	1025	1150	1275	1600
H	180	205	215	275	300	350	390	450	500	555	630	800	1000

FIG. P173 - RETENCIÓN A CLAPETA PRESSURE SEAL ACERO CARBONO/INOX PN160 RF F8

DN	50	65	80	100	125	150	200	250	300	350	400	500	600
L (BW)	300	360	390	450	525	600	750	900	1050	1200	1350	1650	-
L (RF)	300	360	390	450	525	600	750	900	1050	1200	1350	1650	-
H	245	260	250	310	340	390	510	580	620	680	740	850	-

FIG. P174 - RETENCIÓN A CLAPETA PRESSURE SEAL ACERO CARBONO/INOX PN250 RF F9

DN	50	65	80	100	125	150	200	250	300	350	400	500	600
L (BW)	350	425	470	550	650	750	950	1150	1350	1550	1750	-	-
L (RF)	350	425	470	550	650	750	950	1150	1350	1550	1750	-	-
H	245	270	290	350	380	420	630	690	750	800	980	-	-

FIG. P175 - RETENCIÓN A CLAPETA PRESSURE SEAL ACERO CARBONO/INOX PN320 RF F9

DN	50	65	80	100	125	150	200	250	300	350	400	500	600
L (BW)	350	425	470	550	650	750	950	1150	1350	1550	1750	-	-
L (RF)	350	425	470	550	650	750	950	1150	1350	1550	1750	-	-
H	245	280	300	380	405	430	650	720	780	-	-	-	-

FIG. P176 - RETENCIÓN A CLAPETA PRESSURE SEAL ACERO CARBONO/INOX PN420 RF F9

DN	50	65	80	100	125	150	200	250	300	350	400	500	600
L (BW)	350	425	470	550	650	750	950	1150	1350	1550	1750	-	-
L (RF)	350	425	470	550	650	750	950	1150	1350	1550	1750	-	-
H	245	280	300	380	405	430	650	720	780	-	-	-	-

DIN EJECUCIONES ESPECIALES

RETENCIÓN TILTING DISC PRESSURE SEAL PN100/420

Retención Tilting Disc Pressure Seal Fig. P17xT		Distancia: F2 / F9
VÁLVULA RETENCIÓN TILTING DISC PRESSURE SEAL PN100/420 RF		
Materiales		
Cuerpo	Acero carbono 1.0619	
Asiento	Acero carbono + HF	
Obturador	Acero carbono + HF	
Junta cuerpo-tapa	Ac. inox / Grafito	
Normas		
Bridas	DN50 a DN600 (*) según DIN 2501	
Inspección y Pruebas	DIN 3352 Part 1 y DIN 3230 Part 3	
Distancia entre caras	EN 558-1 (ant. DIN 3202)	
(*) Otras medidas bajo demanda		

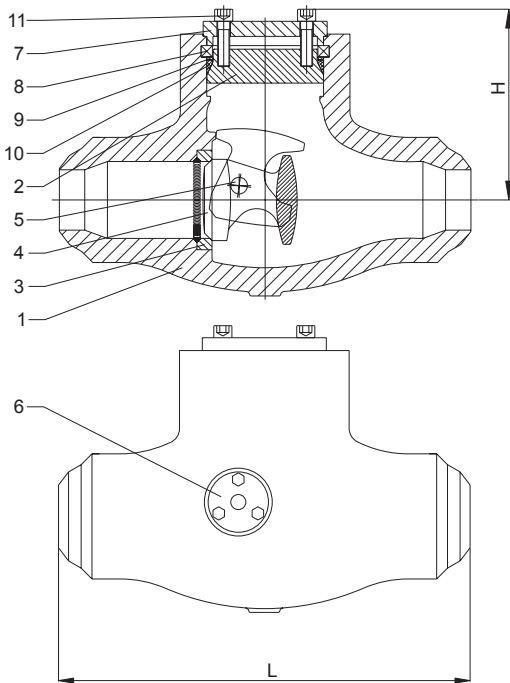
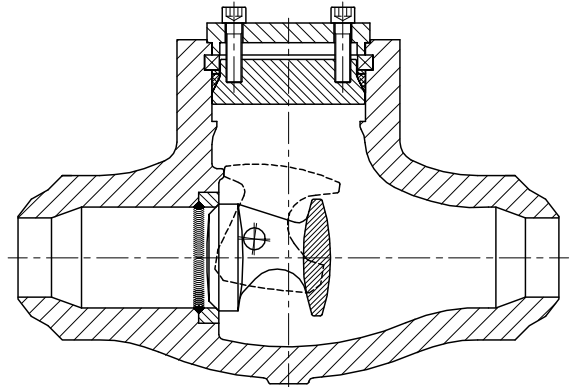

Componentes			
Pos.	Denominación		Materiales estándar (*)
1	Cuerpo	1.0619	1.4581
2	Tapa	1.0619	1.4581
3	Superficie asientos cuerpo	1.0460 +HF	X2 Cr Ni Mo 17 12 2 +HF
4	Superficie asientos clapeta	1.0619 +HF	1.4581 +HF
5	Pasador	X5 Cr Ni Mo 17 12 2	X5 Cr Ni Mo 17 12 2
6	Macho	1.0460	X5 Cr Ni Mo 17 12 2
7	Brida retén	1.0460	1.4401
8	Anillo retén segmentado	X20 Cr 13	1.4401
9	Anillo espaciador	X20 Cr 13	1.4401
10	Junta cuerpo-tapa	Ac. inox / Grafito	Ac. inox / Grafito
11	Tornillo	CK 35	A2 70

(*) Otros materiales bajo demanda

FIG. P172T - RETENCIÓN TILTING DISC PRESSURE SEAL ACERO CARBONO/INOX PN100 RF F2

DN	50	65	80	100	125	150	200	250	300	350	400	500	600
L (BW)	300	340	380	430	500	550	650	775	900	1025	1150	1275	1600
L (RF)	300	340	380	430	500	550	650	775	900	1025	1150	1275	1600
H	180	205	215	275	300	350	390	450	500	555	630	800	1000

FIG. P173T - RETENCIÓN TILTING DISC PRESSURE SEAL ACERO CARBONO/INOX PN160 RF F8

DN	50	65	80	100	125	150	200	250	300	350	400	500	600
L (BW)	300	30	390	450	525	600	750	900	1050	1200	1350	1650	-
L (RF)	300	360	390	450	525	600	750	900	1050	1200	1350	1650	-
H	245	260	250	310	340	390	510	580	620	680	740	850	-

FIG. P174T - RETENCIÓN TILTING DISC PRESSURE SEAL ACERO CARBONO/INOX PN250 RF F9

DN	50	65	80	100	125	150	200	250	300	350	400	500	600
L (BW)	350	425	470	550	650	750	950	1150	1350	1550	1750	-	-
L (RF)	350	425	470	550	650	750	950	1150	1350	1550	1750	-	-
H	245	270	290	350	380	420	630	690	750	800	980	-	-

FIG. P175T - RETENCIÓN TILTING DISC PRESSURE SEAL ACERO CARBONO/INOX PN320 RF F9

DN	50	65	80	100	125	150	200	250	300	350	400	500	600
L (BW)	350	425	470	550	650	750	950	1150	1350	1550	1750	-	-
L (RF)	350	425	470	550	650	750	950	1150	1350	1550	1750	-	-
H	245	280	300	380	405	430	650	720	780	840	1010	-	-

FIG. P176T - RETENCIÓN TILTING DISC PRESSURE SEAL ACERO CARBONO/INOX PN420 RF F9

DN	50	65	80	100	125	150	200	250	300	350	400	500	600
L (BW)	350	425	470	550	650	750	950	1150	1350	1550	1750	-	-
L (RF)	350	425	470	550	650	750	950	1150	1350	1550	1750	-	-
H	245	280	300	380	405	430	650	720	780	840	1010	-	-

DIN EJECUCIONES ESPECIALES

RETENCIÓN PISTÓN PRESSURE SEAL PN100/420

Retención Pistón Pressure Seal Fig. P16xPC		Distancia: F2 / F9
VÁLVULA RETENCIÓN PISTÓN PRESSURE SEAL PN100/420 RF		
Materiales		
Cuerpo	Acero carbono 1.0619	
Asiento	Acero carbono + HF	
Obturador	Acero carbono + HF	
Junta cuerpo-tapa	Ac. inox / Grafito	
Normas		
Bridas	DN50 a DN600 (*) según DIN 2501	
Inspección y Pruebas	DIN 3352 Part 1 y DIN 3230 Part 3	
Distancia entre caras	EN 558-1 (ant. DIN 3202)	
(*) Otras medidas bajo demanda		

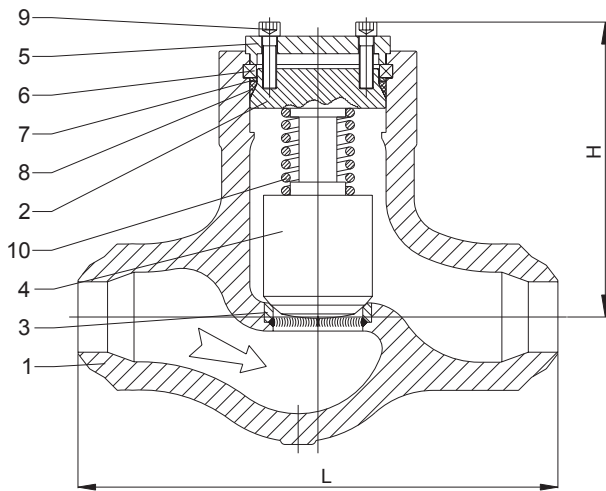
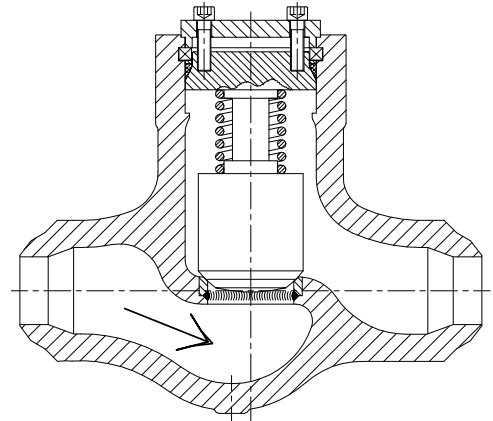

Componentes			
Pos.	Denominación		Materiales estándar (*)
1	Cuerpo	1.0619	1.4581
2	Tapa	1.0619	1.4581
3	Superficie asientos cuerpo	1.0460 +HF	X2 Cr Ni Mo 17 12 2
4	Superficie asientos clapeta	1.0619 +HF	1.4581 +HF
5	Brida retén	1.0460	1.4401
6	Anillo retén segmentado	X20 Cr 13	1.4401
7	Anillo espaciador	X20 Cr 13	1.4401
8	Junta cuerpo-tapa	Ac. inox / Grafito	Ac. inox / Grafito
9	Tornillo	CK 35	A2 70
10	Muelle	X5 Cr Ni Mo 17 12 2	X5 Cr Ni Mo 17 12 2

(*) Otros materiales bajo demanda

FIG. P162PC - RETENCIÓN PISTÓN PRESSURE SEAL ACERO CARBONO/INOX PN100 RF F2

DN	50	65	80	100	125	150	200	250	300	350	400	500	600
L (BW)	300	340	380	430	500	550	650	775	900	1025	1150	1275	1600
L (RF)	300	340	380	430	500	550	650	775	900	1025	1150	1275	1600
H	230	260	280	330	360	450	520	600	700	-	-	-	-

FIG. P163PC - RETENCIÓN PISTÓN PRESSURE SEAL ACERO CARBONO/INOX PN160 RF F8

DN	50	65	80	100	125	150	200	250	300	350	400	500	600
L (BW)	300	360	390	450	525	600	750	900	1050	1200	1350	1650	-
L (RF)	300	360	390	450	525	600	750	900	1050	1200	1350	1650	-
H	270	285	300	390	410	430	520	600	700	-	-	-	-

FIG. P164PC - RETENCIÓN PISTÓN PRESSURE SEAL ACERO CARBONO/INOX PN250 RF F9

DN	50	65	80	100	125	150	200	250	300	350	400	500	600
L (BW)	350	425	470	550	650	750	950	1150	1350	1550	1750	-	-
L (RF)	350	425	470	550	650	750	950	1150	1350	1550	1750	-	-
H	270	290	310	400	420	440	530	620	720	-	-	-	-

FIG. P165PC - RETENCIÓN PISTÓN PRESSURE SEAL ACERO CARBONO/INOX PN320 RF F9

DN	50	65	80	100	125	150	200	250	300	350	400	500	600
L (BW)	350	425	470	550	650	750	950	1150	1350	1550	1750	-	-
L (RF)	350	425	470	550	650	750	950	1150	1350	1550	1750	-	-
H	270	290	310	400	420	440	530	620	720	-	-	-	-

FIG. P166PC - RETENCIÓN PISTÓN PRESSURE SEAL ACERO CARBONO/INOX PN420 RF F9

DN	50	65	80	100	125	150	200	250	300	350	400	500	600
L (BW)	350	425	470	550	650	750	950	1150	1350	1550	1750	-	-
L (RF)	350	425	470	550	650	750	950	1150	1350	1550	1750	-	-
H	270	290	310	400	420	440	530	620	720	-	-	-	-

DIN EJECUCIONES ESPECIALES

RETENCIÓN PISTÓN PRESSURE SEAL EN 'Y' PN100/420

Retención Pistón 'Y' Pressure Seal Fig. P18xPC		Distancia: F2 / F9
VÁLVULA RETENCIÓN PISTÓN 'Y' PRESSURE SEAL PN100/420 RF		
Materiales		
Cuerpo	Acero carbono 1.0619	
Asiento	Acero carbono + HF	
Obturador	Acero carbono + HF	
Junta cuerpo-tapa	Ac. inox / Grafito	
Normas		
Bridas	DN50 a DN600 (*) según DIN 2501	
Inspección y Pruebas	DIN 3352 Part 1 y DIN 3230 Part 3	
Distancia entre caras	EN 558-1 (ant. DIN 3202)	
(*) Otras medidas bajo demanda		

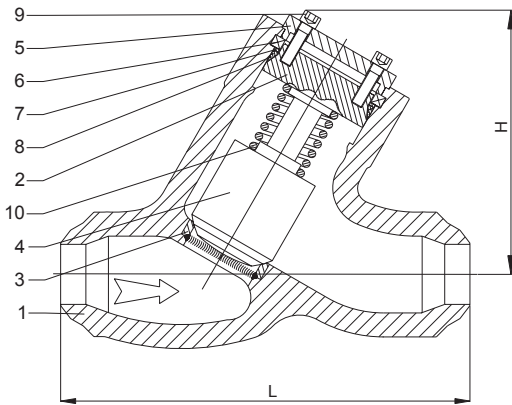
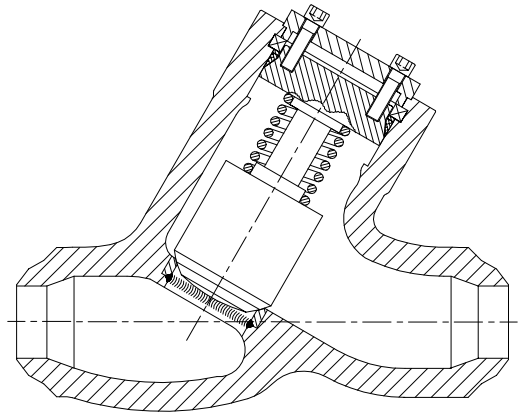

Componentes			
Pos.	Denominación		Materiales estándar (*)
1	Cuerpo	1.0619	1.4581
2	Tapa	1.0619	1.4581
3	Superficie asientos cuerpo	1.0460 +HF	X2 Cr Ni Mo 17 12 2
4	Superficie asientos clapeta	1.0619 +HF	1.4581 +HF
5	Brida retén	1.0460	1.4401
6	Anillo retén segmentado	X20 Cr 13	1.4401
7	Anillo espaciador	X20 Cr 13	1.4401
8	Junta cuerpo-tapa	Ac. inox / Grafito	Ac. inox / Grafito
9	Tornillo	CK 35	A2 70
10	Muelle	X5 Cr Ni Mo 17 12 2	X5 Cr Ni Mo 17 12 2

(*) Otros materiales bajo demanda

FIG. P182PC - RETENCIÓN PISTÓN 'Y' PRESSURE SEAL ACERO CARBONO/INOX PN100 RF F2

DN	50	65	80	100	125	150	200	250	300	350	400	500	600
L (BW)	300	340	380	430	500	550	650	775	900	1025	1150	1275	1600
L (RF)	300	340	380	430	500	550	650	775	900	1025	1150	1275	1600
H	230	260	280	330	360	450	520	600	700	-	-	-	-

FIG. P183PC - RETENCIÓN PISTÓN 'Y' PRESSURE SEAL ACERO CARBONO/INOX PN160 RF F8

DN	50	65	80	100	125	150	200	250	300	350	400	500	600
L (BW)	300	360	390	450	525	600	750	900	1050	1200	1350	1650	-
L (RF)	300	360	390	450	525	600	750	900	1050	1200	1350	1650	-
H	270	285	300	390	410	430	520	600	700	-	-	-	-

FIG. P184PC - RETENCIÓN PISTÓN 'Y' PRESSURE SEAL ACERO CARBONO/INOX PN250 RF F9

DN	50	65	80	100	125	150	200	250	300	350	400	500	600
L (BW)	350	425	470	550	650	750	950	1150	1350	1550	1750	-	-
L (RF)	350	425	470	550	650	750	950	1150	1350	1550	1750	-	-
H	270	290	310	400	420	440	530	620	720	-	-	-	-

FIG. P185PC - RETENCIÓN PISTÓN 'Y' PRESSURE SEAL ACERO CARBONO/INOX PN320 RF F9

DN	50	65	80	100	125	150	200	250	300	350	400	500	600
L (BW)	350	425	470	550	650	750	950	1150	1350	1550	1750	-	-
L (RF)	350	425	470	550	650	750	950	1150	1350	1550	1750	-	-
H	270	290	310	400	420	440	530	620	720	-	-	-	-

FIG. P186PC - RETENCIÓN PISTÓN 'Y' PRESSURE SEAL ACERO CARBONO/INOX PN420 RF F9

DN	50	65	80	100	125	150	200	250	300	350	400	500	600
L (BW)	350	425	470	550	650	750	950	1150	1350	1550	1750	-	-
L (RF)	350	425	470	550	650	750	950	1150	1350	1550	1750	-	-
H	270	290	310	400	420	440	530	620	720	-	-	-	-

VÁLVULAS FORJADAS



FORGED STEEL VALVES



VÁLVULAS FORJADAS

Douglas Chero se estableció en 1974 para satisfacer la demanda de alta calidad de válvulas forjadas en el refinio y plantas de producción de petróleo, yacimientos de gas, industria de la energía, fertilizantes químicos y plantas de desalinización en todo el mundo.

La capacidad de producción de unas 3.000 piezas por mes en 1974 pasó a ser en la actualidad de 40.000 piezas en nuestra nueva fábrica gracias a las más modernas instalaciones de mecanizado y tecnologías de fabricación.

La fábrica tiene un área de 25.000 m², de los cuales 9.000 m² están cubiertos.

GAMA DE FABRICACIÓN

Tipos. Compuerta, Globo/Globo y Retención/Aguja, Retención a Clapeta/Bola/Pistón, y Servicio Urea.

Sellado del cuerpo. Tapa roscada o soldada, sin tapa y Pressure seal.

Ejecuciones. Paso recto, Paso angular o en 'Y', tipo Fuelle, Servicio Criogénico, Servicio Vacío, OS&Y (Husillo exterior ascendente), ISRS, ...

Motorizadas. Con actuador eléctrico, neumático, etc.

Tamaños. 1/4" a 2" en Paso total y reducido (Servicio Urea hasta 8")

Conexiones. SW, Roscadas, BW (Butt weld), Hub y Bridas (integrales)

Rating. ANSI clase 150 a 4500 LBS

MATERIALES

- » Acero carbono - ASTM A105
- » Acero calmado - ASTM A350 LF2

- » Aceros aleados - ASTM A182 - F5, F9, F11, F22, F91
- » Aceros inoxidables - ASTM A182/F304(L), F316(L), F317, F321, F347, F44
- » Aleaciones especiales - Monel, Inconel, Incoloy, Hastelloy, UNS, Alloy 20, Sanicro 28, Titanio, ...
- » Duplex - ASTM A182 F51, F53, F55

CALIDAD

- » Certificados de Materiales
- » Ensayos no destructivos, Análisis Químicos y Mecánicos
- » Pruebas Hidrostáticas
- » Pruebas Neumáticas
- » Ensayo de funcionamiento
- » Prueba Criogénica
- » Ensayos especiales bajo demanda



DOUGLAS CHERO SpA
dc FORGED STEEL VALVES

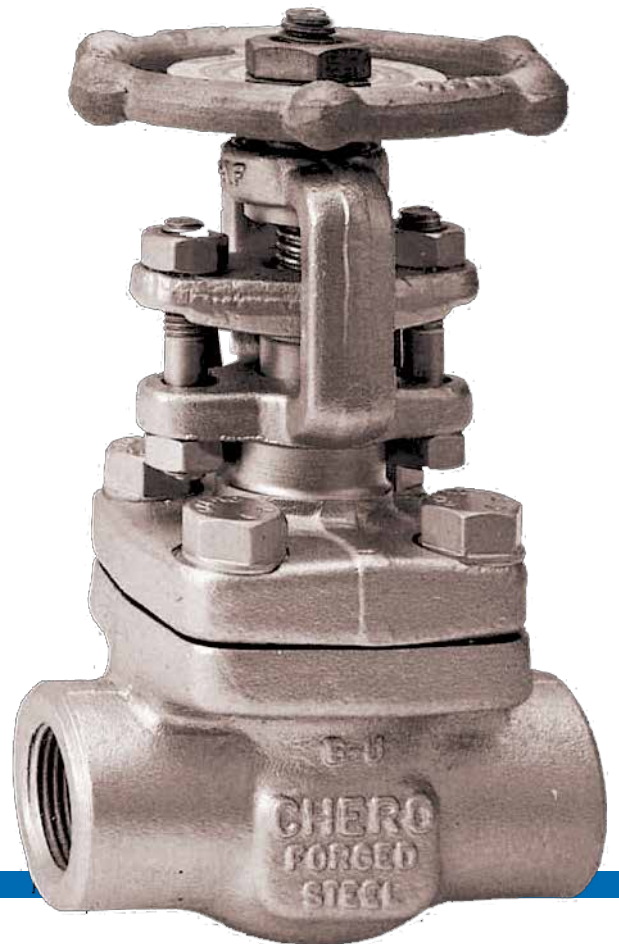

FORGED STEEL VALVES

VÁLVULAS FORJADAS - LISTA DE MATERIALES DE CONSTRUCCIÓN

ELEMENTOS DE LA VÁLVULA					MATERIALES				
COMPUERTA GLOBO	RETENCIÓN PISTÓN/BOLA	COMPUERTA GLOBO (SERV. CRIOGÉNICO)	COMPUERTA GLOBO (TIPO FUELLE)	COMPUERTA GLOBO (ISRS)	Acero Carbono	Acero Carbono Calmado	Acero Aleado	Acero Inoxidable Duplex	Acero Níquel
Cuerpo Tapa	Cuerpo Extensión-Tapa	Cuerpo Tapa Extensión	Cuerpo Tapa	Cuerpo Tapa Tuerca-Prensa	A105N	A350 LF2	A182 F1 A182 F5 A182 F9 A182 F11 A182 F22 F44 F51 F53 F55	A182 F304 A182 F304L A182 F316 A182 F316L A182 F321 A182 F347	Monel 400 Inconel 600 Incoloy 800H Incoloy 825 Hastelloy C276 Hastelloy B2
Husillo Cuña/Disco Asiento(s) Tuerca Disco	Disco/Bola Asiento	Husillo Cuña/Disco Asiento(s) Tuerca Disco	Husillo Cuña/Disco Asiento(s)	Husillo Cuña/Disco Asiento(s) Tuerca Disco Anillo Empaquet.	A182 F6 A182 F304 F182 F316	A182 F6 A182 F304 A182 F316 F44 F51 F53 F55	A182 F6 A182 F304 A182 F316 F44 F51 F53 F55	A182 F304 A182 F316 A182 F321 A182 F347	Monel 400 Inconel 600 Inconel 625 Incoloy 800H Incoloy 825 Hastelloy C276 Hastelloy B2
Prensa-estopas		Prensa-es-topas	Prensa-estopas		AISI 416/303/316	AISI 416/303/316	AISI 416/303/316	AISI 303/316	AISI 303/316
Tuerca Husillo		Tuerca Husillo	Tuerca Husillo		AISI 416	AISI 416	AISI 416	AISI 416	AISI 416
Brida Prensa		Brida Prensa	Brida Prensa		A105N	A105N	A182 F304	A182 F304	A182 F304
Volante Tuerca Vol.		Volante Tuerca Vol.	Volante Tuerca Vol.	Volante Tuerca Vol.	Acero Carbono	Acero Carbono	Acero Carbono	Acero Carbono	Acero Carbono
	Muelle				Acero Inox.	Acero Inox.	Acero Inox.	Acero Inox.	Acero Inox.
Junta	Junta	Junta	Junta		AISI 316/ Grafito	AISI 316/ Grafito	AISI 316/ Grafito	AISI 316/ Grafito	AISI 316/ Grafito
Empaquet.		Empaquet.	Empaquet.	Empaquet.	Grafito	Grafito	Grafito	Grafito	
Tornillos cuerpo Tuercas cuerpo	Tornillos cuerpo Tuercas cuerpo	Tornillos cuerpo Tuercas cuerpo	Tornillos cuerpo Tuercas cuerpo		A193 B7 A194 2H	A193 B8 A194 Gr. 8	A193 B16 A194 Gr. 4	A193 B8 A194 Gr. 8	A193 B8 A194 Gr. 8
Tornillos prensa Tuercas prensa		Tornillos prensa Tuercas prensa	Tornillos prensa Tuercas prensa		AISI 410 A194 2H	A193 B8 A194 Gr. 8	AISI 410 A194 Gr. 4	A193 B8 A194 Gr. 8	A193 B8 A194 Gr. 8
		Fuelle			AISI 316L Hastelloy C276	AISI 316L Hastelloy C276	AISI 316L Hastelloy C276	AISI 316L Hastelloy C276	AISI 316L Hastelloy C276
	Biela Clapeta				A182 F6/ A182 F316	A182 F6/ A182 F316	A182 F6/ A182 F316	A182 F6/ A182 F316	A182 F6/ A182 F316
Placa identif.	Placa identif.	Placa identif.	Placa identif.	Placa identif.	Aluminio	Aluminio	Aluminio	Aluminio	Aluminio

VÁLVULAS FORJADAS - DISTANCIA ENTRE CARAS SEGÚN ASME B16.10

150 LBS										
	1/2"		3/4"		1"		1.1/2"		2"	
	RF	RTJ	RF	RTJ	RF	RTJ	RF	RTJ	RF	RTJ
Compuerta	107.9	119.1	117.5	130.2	127	139.7	165.1	177.8	177.8	190.5
Globo Retención (Pistón, Bola y Clapeta)	107.9	119.1	117.5	130.2	127	139.7	165.1	177.8	203.2	215.9

300 LBS										
	1/2"		3/4"		1"		1.1/2"		2"	
	RF	RTJ	RF	RTJ	RF	RTJ	RF	RTJ	RF	RTJ
Compuerta	139.7	150.8	152.4	165.1	165.1	177.8	190.5	203.2	215.9	231.8
Globo Retención (Pistón y Bola)	152.4	163.5	177.8	190.5	203.2	215.9	228.6	241.3	266.7	282.6
Retención (Clapeta)	152.4	163.5	177.8	190.5	215.9	228.6	241.3	254	266.7	282.6

600 LBS										
	1/2"		3/4"		1"		1.1/2"		2"	
	RF	RTJ	RF	RTJ	RF	RTJ	RF	RTJ	RF	RTJ
Compuerta, Globo y Retención (Pistón, Bola y Clapeta)	165.1	163.5	190.5	190.5	215.9	215.9	241.3	241.3	292.1	295.3

1500 LBS										
	1/2"		3/4"		1"		1.1/2"		2"	
	RF	RTJ	RF	RTJ	RF	RTJ	RF	RTJ	RF	RTJ
Compuerta, Globo y Retención (Pistón, Bola y Clapeta)	215.9	215.9	228.6	228.6	254	254	304.8	304.8	368.3	371.5

2500 LBS										
	1/2"		3/4"		1"		1.1/2"		2"	
	RF	RTJ	RF	RTJ	RF	RTJ	RF	RTJ	RF	RTJ
Compuerta, Globo y Retención (Pistón, Bola y Clapeta)	263.5	263.5	273	273	308	308	384.2	387.3	450.8	454

CONEXIONES

SW Socket Weld	BX Butt Weld Sch.XXS	ST Small tongue	SNB SW/Ext.BW80	SNW SW/Ext.Weld
TH Rosca NPT	RF Bridas con resalte	LF Large female	TNS NPT/Ext.SW	TNW NPT/Ext.Weld
TS SW x NPT	FF Bridas cara plana	LG Large groove	TNT NPT/Ext.NPT	
SE SW(e) x NPT	RJ Ring joint	LM Large male	TNB NPT/Ext.BW80	
B4 Butt Weld Sch.40	SF Small Female	LT Large tongue	BNS BW80/Ext.SW	
B6 Butt Weld Sch.160	SG Small groove	SNS SW/Ext.SW	BNT BW80/Ext.NPT	
B8 Butt Weld Sch.80	SM Small male	SNT SW/Ext.NPT	BNB BW80/Ext.BW80	

VÁLVULAS FORJADAS ANSI

COMPUERTA 800LBS SW/NPT/BW BOLTED BONNET

DOUGLAS CHERO COMPUERTA Fig. R25x		Clase: 800LBS
Válvula Compuerta Acero Carbono 800LBS SW/NPT/BW		
Especificaciones		
Material	Acero carbono ASTM A105 ¹	
Presiones	800 p.s.i. a 454°C 1.975 p.s.i. a 38°C	
Pruebas	Hidráulica (mínima): Cuerpo 3.000 p.s.i. Asiento 2.175 p.s.i. Aire bajo el agua: Asiento 85 p.s.i.	
Normas	Construcción API 602, ISO 15761 Socket Welding ASME B16.11 Rosca ASME B1.20.1 Butt Welding ASME B16.25	
¹ Ver lista de materiales de construcción		

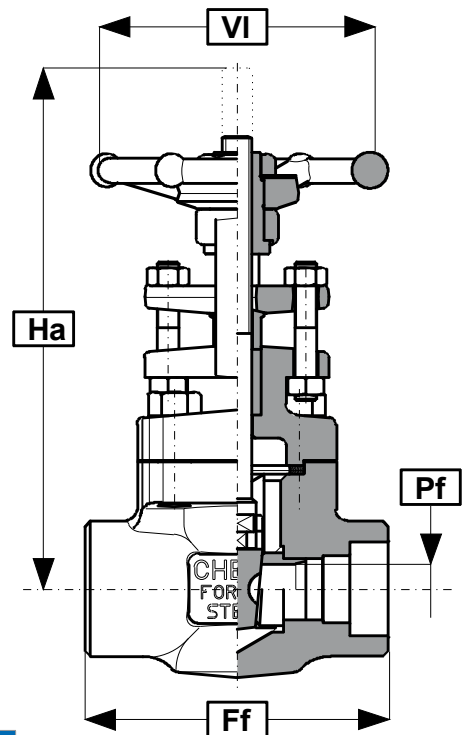

FIG. R25x - COMPUERTA A105/F6 TRIM N° 1 - 800LBS SW

Código	DN	Ff (mm)	Ha (mm)	VI (mm)	Pf (mm)	Peso (kg)
010102304041310	1/4"	80	143	90	8.5	1.8
010102304041309	3/8"	80	145	90	10	1.8
010102304040435	1/2"	80	145	90	10	1.7
010102304040436	3/4"	90	156	90	14	2.1
010102304040439	1"	110	186	100	18	3.3
010102304040466	1.1/4"	127	216	120	24	5.2
010102304040460	1.1/2"	127	255	140	31	7.0
010102304040459	2"	130	273	140	36.5	9.1

FIG. R25x - COMPUERTA A105/F6 U TRIM N° 5 - 800LBS SW

Código	DN	Ff (mm)	Ha (mm)	VI (mm)	Pf (mm)	Peso (kg)
010102304041328	1/4"	80	143	90	8.5	1.8
-	3/8"	80	145	90	10	1.8
010102304040640	1/2"	80	145	90	10	1.7
010102304040651	3/4"	90	156	90	14	2.1
010102304040652	1"	110	186	100	18	3.3
010102304041326	1.1/4"	127	216	120	24	5.2
010102304040653	1.1/2"	127	255	140	31	7.0
010102304040654	2"	130	273	140	36.5	9.1

FIG. R25x - COMPUERTA A105/F316 TRIM N° 10 - 800LBS SW

Código	DN	Ff (mm)	Ha (mm)	VI (mm)	Pf (mm)	Peso (kg)
-	1/4"	80	143	90	8.5	1.8
-	3/8"	80	145	90	10	1.8
010102304040665	1/2"	80	145	90	10	1.7
010102304040662	3/4"	90	156	90	14	2.1
010102304040655	1"	110	186	100	18	3.3
-	1.1/4"	127	216	120	24	5.2
010102304040564	1.1/2"	127	255	140	31	7.0
010102304042954	2"	130	273	140	36.5	9.1

FIG. R25x - COMPUERTA A105/F6 TRIM N° 1 - 800LBS NPT

Código	DN	Ff (mm)	Ha (mm)	Vi (mm)	Pf (mm)	Peso (kg)
010102304041146	1/4"	80	143	90	8.5	1.8
010102304041145	3/8"	80	145	90	10	1.8
010102304040570	1/2"	80	145	90	10	1.7
010102304040581	3/4"	90	156	90	14	2.1
010102304040574	1"	110	186	100	18	3.3
010102304040575	1.1/4"	127	216	120	24	5.2
010102304040548	1.1/2"	127	255	140	31	7.0
010102304040549	2"	130	273	140	36.5	9.1

FIG. R25x - COMPUERTA A105/F6 U TRIM N° 5 - 800LBS NPT

Código	DN	Ff (mm)	Ha (mm)	Vi (mm)	Pf (mm)	Peso (kg)
-	1/4"	80	143	90	8.5	1.8
-	3/8"	80	145	90	10	1.8
-	1/2"	80	145	90	10	1.7
010102304040555	3/4"	90	156	90	14	2.1
010102304040618	1"	110	186	100	18	3.3
-	1.1/4"	127	216	120	24	5.2
010102304040590	1.1/2"	127	255	140	31	7.0
010102304040595	2"	130	273	140	36.5	9.1

» Diseño Paso Total y ejecuciones especiales, bajo demanda

VÁLVULAS FORJADAS ANSI

COMPUERTA 800LBS SW/NPT/BW WELDED BONNET

DOUGLAS CHERO COMPUERTA Fig. R25xWB		Clase: 800LBS
Válvula Compuerta Acero Carbono 800LBS SW/NPT/BW Welded Bonnet		
Especificaciones		
Material	Acero carbono ASTM A105 ¹	
Presiones	800 p.s.i. a 454°C 1.975 p.s.i. a 38°C	
Pruebas	Hidráulica (mínima): Cuerpo 3.000 p.s.i. Asiento 2.175 p.s.i. Aire bajo el agua: Asiento 85 p.s.i.	
Normas	Construcción API 602, ISO 15761 Socket Welding ASME B16.11 Rosca ASME B1.20.1 Butt Welding ASME B16.25	
¹ Ver lista de materiales de construcción		

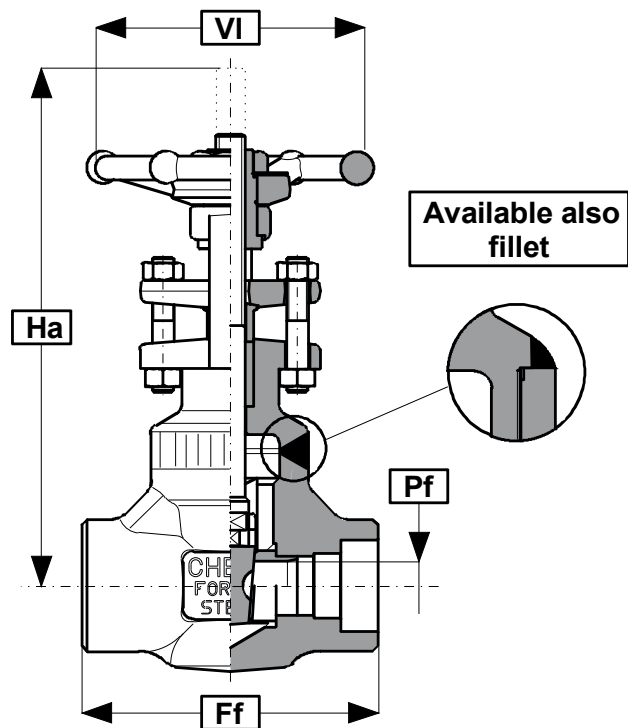

FIG. R25xWB - COMPUERTA A105/F6 TRIM N° 1 - 800LBS SW W.B.

Código	DN	Ff (mm)	Ha (mm)	VI (mm)	Pf (mm)	Peso (kg)
-	1/2"	80	150	90	10	1.4
-	3/4"	90	157	90	14	1.7
-	1"	110	188	100	18	2.8
-	1.1/4"	127	220	120	24	4.4
-	1.1/2"	127	248	140	31	5.6
-	2"	130	274	140	36.5	7.6

FIG. R25xWB - COMPUERTA A105/F6 U TRIM N° 5 - 800LBS SW W.B.

Código	DN	Ff (mm)	Ha (mm)	VI (mm)	Pf (mm)	Peso (kg)
-	1/2"	80	150	90	10	1.4
-	3/4"	90	157	90	14	1.7
010102304044303	1"	110	188	100	18	2.8
-	1.1/4"	127	220	120	24	4.4
-	1.1/2"	127	248	140	31	5.6
-	2"	130	274	140	36.5	7.6

» Diseño Paso Total y ejecuciones especiales, bajo demanda

COMPUERTA 150LBS RF BOLTED BONNET

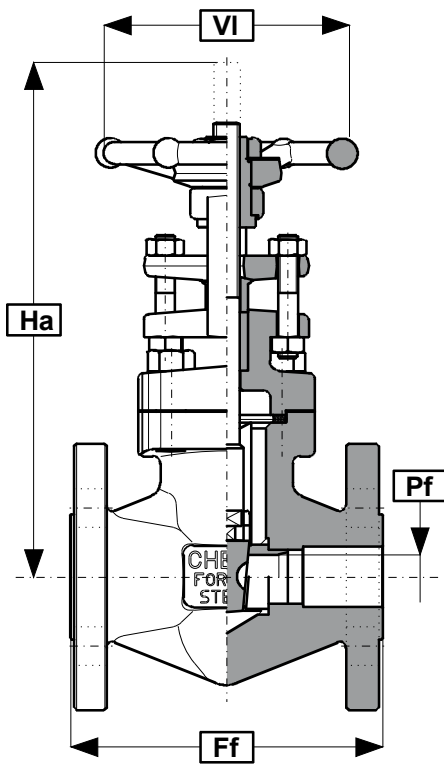

DOUGLAS CHERO COMPUERTA Fig. R35x/15		Clase: 150LBS
Válvula Compuerta Acero Carbono 150LBS RF		
Especificaciones		
Material	Acero carbono ASTM A105 ¹	
Presiones	150 p.s.i. a 288°C 285 p.s.i. a 38°C	
Pruebas	Hidráulica (mínima): Cuerpo 450 p.s.i. Asiento 325 p.s.i. Aire bajo el agua: Asiento 85 p.s.i.	
Normas	Construcción API 602, ISO 15761 Bridas ASME B16.5, ASME B16.10	
¹ Ver lista de materiales de construcción		

FIG. R35x/15 - COMPUERTA A105/F6 TRIM N° 1 - 150LBS RF

Código	DN	Ff (mm)	Ha (mm)	VI (mm)	Pf (mm)	Peso (kg)
010102304041475	1/2"	107.9	179	90	10	3.2
010102304041474	3/4"	117.5	186	90	14	4.1
010102304041473	1"	127.0	208	100	18	5.8
-	1.1/4"					
010102304041462	1.1/2"	165.1	255	140	31	10
010102304041461	2"	177.8	273	140	36.5	13.1

FIG. R35x/15 - COMPUERTA A105/F6 U TRIM N° 5 - 150LBS RF

Código	DN	Ff (mm)	Ha (mm)	VI (mm)	Pf (mm)	Peso (kg)
-	1/2"	107.9	179	90	10	3.2
-	3/4"	117.5	186	90	14	4.1
-	1"	127.0	208	100	18	5.8
-	1.1/4"					
-	1.1/2"	165.1	255	140	31	10
-	2"	177.8	273	140	36.5	13.1

» Diseño Paso Total y ejecuciones especiales, bajo demanda

VÁLVULAS FORJADAS ANSI

COMPUERTA 300LBS RF BOLTED BONNET

DOUGLAS CHERO COMPUERTA Fig. R35x/30		Clase: 300LBS
Válvula Compuerta Acero Carbono 300LBS RF		
Especificaciones		
Material	Acero carbono ASTM A105 ¹	
Presiones	300 p.s.i. a 454°C 740 p.s.i. a 38°C	
Pruebas	Hidráulica (mínima): Cuerpo 1.125 p.s.i. Asiento 825 p.s.i. Aire bajo el agua: Asiento 85 p.s.i.	
Normas	Construcción API 602, ISO 15761 Bridas ASME B16.5, ASME B16.10	
¹ Ver lista de materiales de construcción		

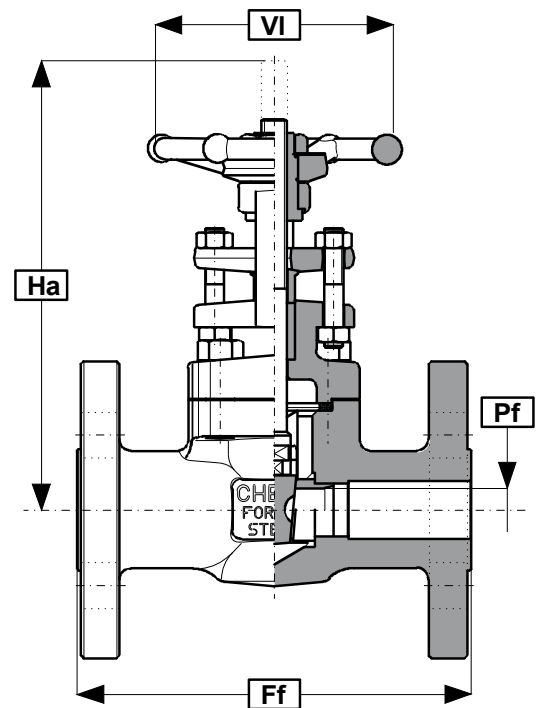

FIG. R35x/30 - COMPUERTA A105/F6 TRIM N° 1 - 300LBS RF

Código	DN	Ff (mm)	Ha (mm)	VI (mm)	Pf (mm)	Peso (kg)
-	1/2"	139.7	145	90	10	3.8
-	3/4"	152.4	156	90	14	5.4
-	1"	165.1	186	100	18	6.5
-	1.1/4"					
010102304041671	1.1/2"	190.5	255	140	31	13.1
-	2"	215.9	273	140	36.5	17.3

FIG. R35x/30 - COMPUERTA A105/F6 U TRIM N° 5 - 300LBS RF

Código	DN	Ff (mm)	Ha (mm)	VI (mm)	Pf (mm)	Peso (kg)
-	1/2"	139.7	145	90	10	3.8
-	3/4"	152.4	156	90	14	5.4
-	1"	165.1	186	100	18	6.5
-	1.1/4"					
-	1.1/2"	190.5	255	140	31	13.1
-	2"	215.9	273	140	36.5	17.3

» Diseño Paso Total y ejecuciones especiales, bajo demanda

COMPUERTA 600LBS RF BOLTED BONNET

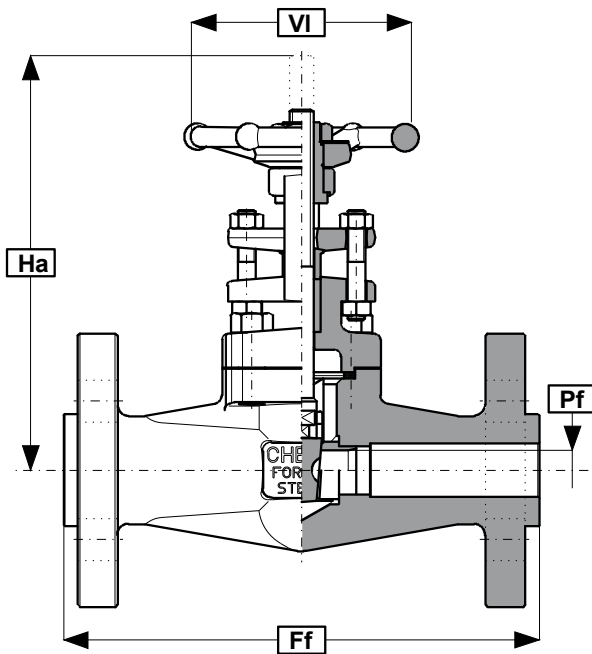

DOUGLAS CHERO COMPUERTA Fig. R35x/60		Clase: 600LBS
Válvula Compuerta Acero Carbono 600LBS RF		
Especificaciones		
Material	Acero carbono ASTM A105 ¹	
Presiones	600 p.s.i. a 454°C 1.480 p.s.i. a 38°C	
Pruebas	Hidráulica (mínima): Cuerpo 2.225 p.s.i. Asiento 1.650 p.s.i. Aire bajo el agua: Asiento 85 p.s.i.	
Normas	Construcción API 602, ISO 15761 Bridas ASME B16.5, ASME B16.10	
¹ Ver lista de materiales de construcción		

FIG. R35x/60 - COMPUERTA A105/F6 TRIM N° 1 - 600LBS RF

Código	DN	Ff (mm)	Ha (mm)	VI (mm)	Pf (mm)	Peso (kg)
-	1/2"	165.1	145	90	10	3.5
-	3/4"	190.5	156	90	14	5.8
-	1"	215.9	186	100	18	7.4
-	1.1/4"					
-	1.1/2"	241.3	255	140	31	14.3
-	2"	292.1	273	140	36.5	18.8

FIG. R35x/60 - COMPUERTA A105/F6 U TRIM N° 5 - 600LBS RF

Código	DN	Ff (mm)	Ha (mm)	VI (mm)	Pf (mm)	Peso (kg)
-	1/2"	165.1	145	90	10	3.5
-	3/4"	190.5	156	90	14	5.8
-	1"	215.9	186	100	18	7.4
-	1.1/4"					
-	1.1/2"	241.3	255	140	31	14.3
-	2"	292.1	273	140	36.5	18.8

» Diseño Paso Total y ejecuciones especiales, bajo demanda

VÁLVULAS FORJADAS ANSI

COMPUERTA 1500LBS SW/NPT/BW BOLTED BONNET

DOUGLAS CHERO COMPUERTA Fig. X65x		Clase: 1500LBS
Válvula Compuerta Acero Carbono 1500LBS SW/NPT/BW		
Especificaciones		
Material	Acero carbono ASTM A105 ¹	
Presiones	1.500 p.s.i. a 454°C 3.705 p.s.i. a 38°C	
Pruebas	Hidráulica (mínima): Cuerpo 5.575 p.s.i. Asiento 4.100 p.s.i. Aire bajo el agua: Asiento 85 p.s.i.	
Normas	Construcción ISO 15761 Socket Welding ASME B16.11 Rosca ASME B1.20.1 Butt Welding ASME B16.25	
¹ Ver lista de materiales de construcción X - Junta espirométrica. Junta RTJ disponible bajo demanda		

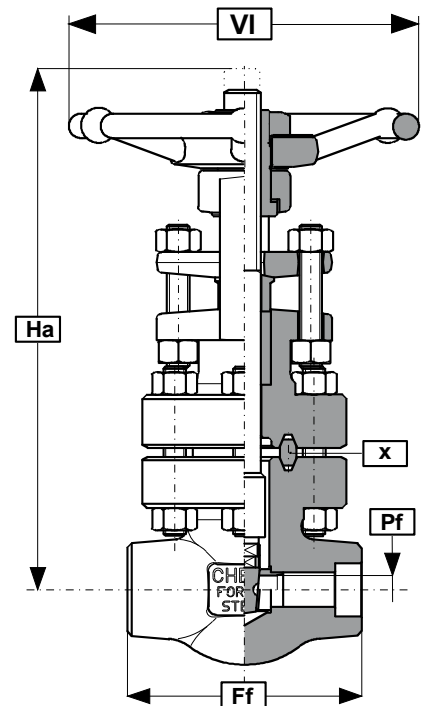

FIG. X65x - COMPUERTA A105/F6 TRIM N° 1 - 1500LBS SW

Código	DN	Ff (mm)	Ha (mm)	VI (mm)	Pf (mm)	Peso (kg)
-	1/2"	110	212	120	11.5	5.9
-	3/4"	115	256	175	15	8.4
-	1"	130	272	175	19.5	9.8
-	1.1/4"					
-	1.1/2"	210	411	260	32	26.8
-	2"	240	422	260	40	35.4

FIG. X65x - COMPUERTA A105/F6 U TRIM N° 5 - 1500LBS SW

Código	DN	Ff (mm)	Ha (mm)	VI (mm)	Pf (mm)	Peso (kg)
-	1/2"	110	212	120	11.5	5.9
-	3/4"	115	256	175	15	8.4
010102304041275	1"	130	272	175	19.5	9.8
-	1.1/4"					
-	1.1/2"	210	411	260	32	26.8
010102304041267	2"	240	422	260	40	35.4

» Diseño Paso Total y ejecuciones especiales, bajo demanda

COMPUERTA 1500LBS SW/NPT/BW WELDED BONNET

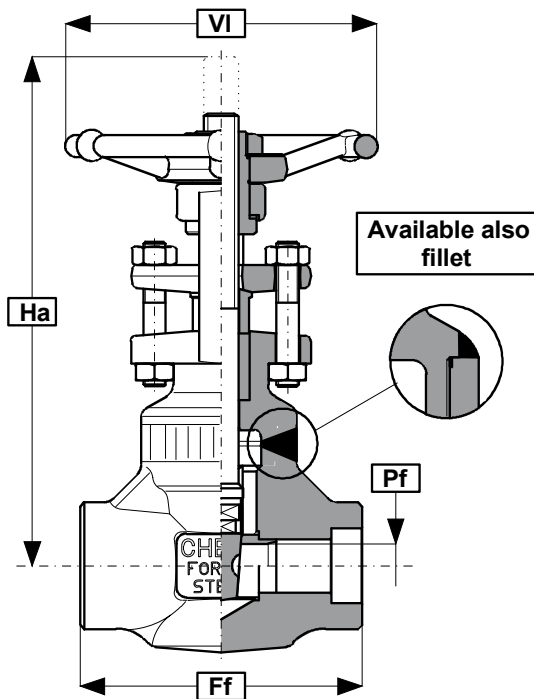

DOUGLAS CHERO COMPUERTA Fig. X65xWB		Clase: 1500LBS
Válvula Compuerta Acero Carbono 1500LBS SW/NPT/BW Welded Bonnet		
Especificaciones		
Material	Acero carbono ASTM A105 ¹	
Presiones	1.500 p.s.i. a 454°C 3.705 p.s.i. a 38°C	
Pruebas	Hidráulica (mínima): Cuerpo 5.575 p.s.i. Asiento 4.100 p.s.i. Aire bajo el agua: Asiento 85 p.s.i.	
Normas	Construcción ISO 15761 Socket Welding ASME B16.11 Rosca ASME B1.20.1 Butt Welding ASME B16.25	
¹ Ver lista de materiales de construcción X - Junta espirometálica. Junta RTJ disponible bajo demanda		

FIG. X65xWB - COMPUERTA A105/F6 TRIM N° 1 - 1500LBS SW W.B.

Código	DN	Ff (mm)	Ha (mm)	VI (mm)	Pf (mm)	Peso (kg)
-	1/2"	90	175	120	11.5	2.0
-	3/4"	110	217	175	15	3.2
-	1"	127	234	175	19.5	4.9
-	1.1/4"					
-	1.1/2"	130	295	200	32	8.5
-	2"	150	375	260	40	15

FIG. X65xWB - COMPUERTA A105/F6 U TRIM N° 5 - 1500LBS SW W.B.

Código	DN	Ff (mm)	Ha (mm)	VI (mm)	Pf (mm)	Peso (kg)
010102304040568	1/2"	90	175	120	11.5	2.0
010102304040567	3/4"	110	217	175	15	3.2
010102304040566	1"	127	234	175	19.5	4.9
-	1.1/4"					
010102304040569	1.1/2"	130	295	200	32	8.5
010102304040552	2"	150	375	260	40	15

» Diseño Paso Total y ejecuciones especiales, bajo demanda

VÁLVULAS FORJADAS ANSI

COMPUERTA 1500LBS RF BOLTED BONNET

DOUGLAS CHERO COMPUERTA Fig. 65x/150		Clase: 1500LBS
Válvula Compuerta Acero Carbono 1500LBS RF		
Especificaciones		
Material	Acero carbono ASTM A105 ¹	
Presiones	1.500 p.s.i. a 454°C 3.705 p.s.i. a 38°C	
Pruebas	Hidráulica (mínima): Cuerpo 5.575 p.s.i. Asiento 4.100 p.s.i. Aire bajo el agua: Asiento 85 p.s.i.	
Normas	Construcción ISO 15761 Bridas ASME B16.5, ASME B16.10	
¹ Ver lista de materiales de construcción X - Junta espirometálica. Junta RTJ disponible bajo demanda		

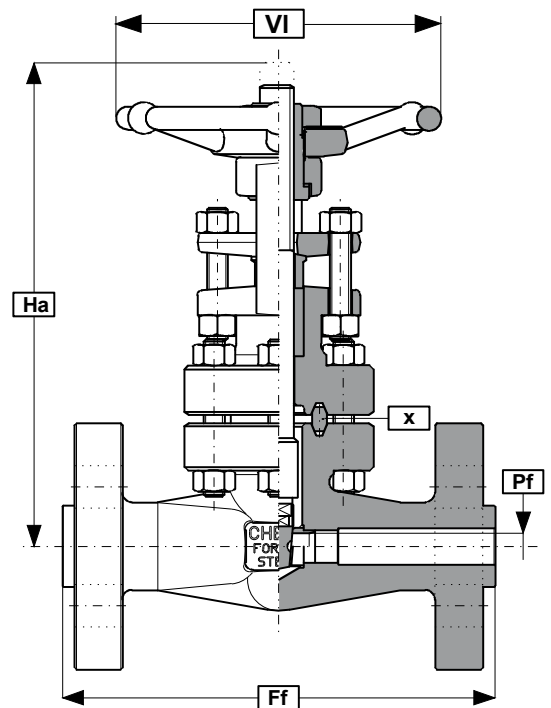

FIG. 65x/150 - COMPUERTA A105/F6 TRIM N° 1 - 1500LBS RF

Código	DN	Ff (mm)	Ha (mm)	VI (mm)	Pf (mm)	Peso (kg)
-	1/2"	215.9	212	120	11.5	9.7
-	3/4"	228.6	256	175	15	15.5
-	1"	254.0	272	175	19.5	17.5
-	1.1/4"					
-	1.1/2"	304.8	411	260	32	38.5
-	2"	368.3	422	260	40	56.0

FIG. 65x/150 - COMPUERTA A105/F6 U TRIM N° 5 - 1500LBS RF

Código	DN	Ff (mm)	Ha (mm)	VI (mm)	Pf (mm)	Peso (kg)
-	1/2"	215.9	212	120	11.5	9.7
-	3/4"	228.6	256	175	15	15.5
-	1"	254.0	272	175	19.5	17.5
-	1.1/4"					
-	1.1/2"	304.8	411	260	32	38.5
-	2"	368.3	422	260	40	56.0

» Diseño Paso Total y ejecuciones especiales, bajo demanda

COMPUERTA 2500LBS SW/NPT/BW BOLTED BONNET

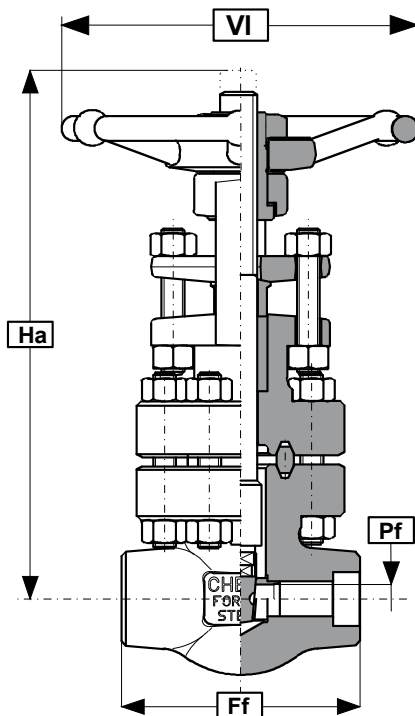

DOUGLAS CHERO COMPUERTA Fig. 105x		Clase: 2500LBS
Válvula Compuerta Acero Carbono 800LBS SW/NPT/BW		
Especificaciones		
Material	Acero carbono ASTM A105 ¹	
Presiones	2.500 p.s.i. a 454°C 6.170 p.s.i. a 38°C	
Pruebas	Hidráulica (mínima): Cuerpo 9.275 p.s.i. Asiento 6.800 p.s.i. Aire bajo el agua: Asiento 85 p.s.i.	
Normas	Construcción ASME B16.34 Socket Welding ASME B16.11 Rosca ASME B1.20.1 Butt Welding ASME B16.25	
¹ Ver lista de materiales de construcción		

FIG. 105x - COMPUERTA A105/F6 TRIM N° 1 - 2500LBS SW

Código	DN	Ff (mm)	Ha (mm)	Vi (mm)	Pf (mm)	Peso (kg)
-	1/2"	110	212	140	10	6.1
-	3/4"	115	256	200	14	8.7
-	1"	130	272	200	18	10.2
-	1.1/4"					
-	1.1/2"	210	411	260	31	27.4
-	2"	240	422	350	36.5	36.2

FIG. 105x - COMPUERTA A105/F6 U TRIM N° 5 - 2500LBS SW

Código	DN	Ff (mm)	Ha (mm)	Vi (mm)	Pf (mm)	Peso (kg)
-	1/2"	110	212	140	10	6.1
-	3/4"	115	256	200	14	8.7
-	1"	130	272	200	18	10.2
-	1.1/4"					
-	1.1/2"	210	411	260	31	27.4
-	2"	240	422	350	36.5	36.2

» Diseño Paso Total y ejecuciones especiales, bajo demanda

VÁLVULAS FORJADAS ANSI

COMPUERTA 2500LBS SW/NPT/BW WELDED BONNET

DOUGLAS CHERO COMPUERTA Fig. 105xWB		Clase: 2500LBS
Válvula Compuerta Acero Carbono 800LBS SW/NPT/BW Welded Bonnet		
Especificaciones		
Material	Acero carbono ASTM A105 ¹	
Presiones	2.500 p.s.i. a 454°C 6.170 p.s.i. a 38°C	
Pruebas	Hidráulica (mínima): Cuerpo 9.275 p.s.i. Asiento 6.800 p.s.i. Aire bajo el agua: Asiento 85 p.s.i.	
Normas	Construcción ASME B16.34 Socket Welding ASME B16.11 Rosca ASME B1.20.1 Butt Welding ASME B16.25	
¹ Ver lista de materiales de construcción		

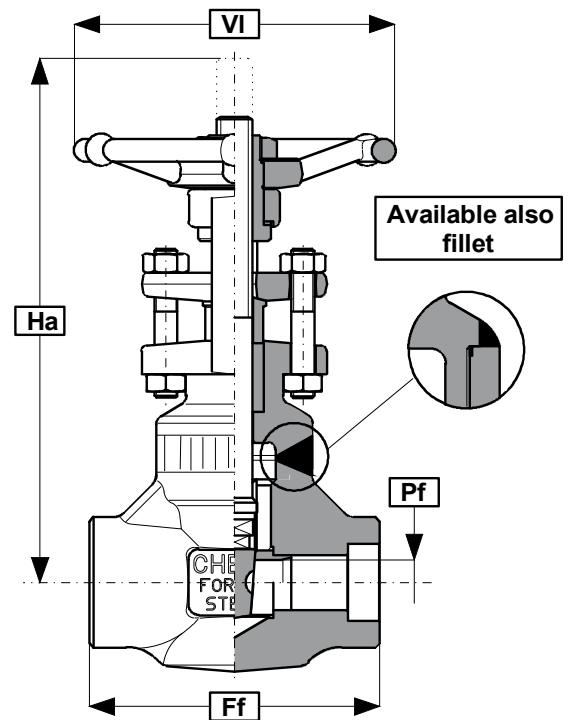

FIG. 105xWB - COMPUERTA A105/F6 TRIM N° 1 - 2500LBS SW W.B.

Código	DN	Ff (mm)	Ha (mm)	VI (mm)	Pf (mm)	Peso (kg)
-	1/2"	110	198	140	10	2.6
-	3/4"	127	225	200	14	4.0
-	1"	127	243	200	18	5.9
-	1.1/4"					
-	1.1/2"	150	387	260	31	10.0
-	2"	240	403	350	36.5	29

FIG. 105xWB - COMPUERTA A105/F6 U TRIM N° 5 - 2500LBS SW W.B.

Código	DN	Ff (mm)	Ha (mm)	VI (mm)	Pf (mm)	Peso (kg)
-	1/2"	110	198	140	10	2.6
-	3/4"	127	225	200	14	4.0
-	1"	127	243	200	18	5.9
-	1.1/4"					
-	1.1/2"	150	387	260	31	10.0
-	2"	240	403	350	36.5	29

» Diseño Paso Total y ejecuciones especiales, bajo demanda

COMPUERTA 2500LBS RF BOLTED BONNET

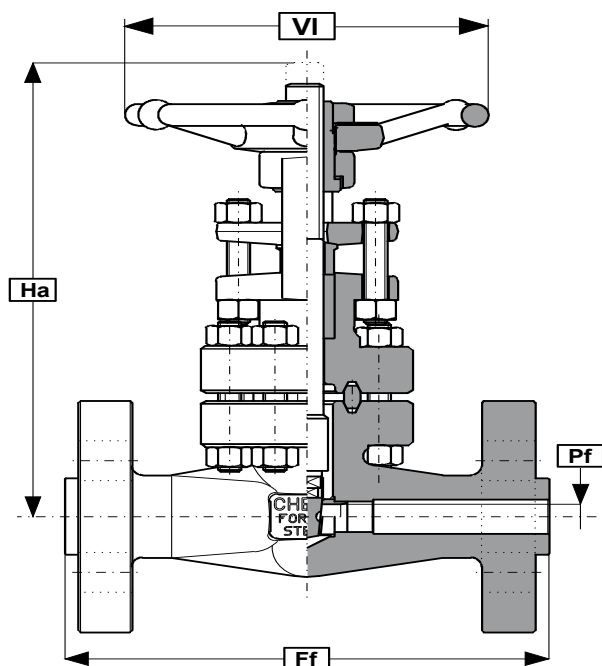

DOUGLAS CHERO COMPUERTA Fig. 115x/250		Clase: 2500LBS
Válvula Compuerta Acero Carbono 2500LBS RF		
Especificaciones		
Material	Acero carbono ASTM A105 ¹	
Presiones	2.500 p.s.i. a 454°C 6.170 p.s.i. a 38°C	
Pruebas	Hidráulica (mínima): Cuerpo 9.275 p.s.i. Asiento 6.800 p.s.i. Aire bajo el agua: Asiento 85 p.s.i.	
Normas	Construcción ASME B16.34 Bridas ASME B16.5, ASME B16.10	
¹ Ver lista de materiales de construcción		

FIG. 115x/250 - COMPUERTA A105/F6 TRIM N° 1 - 2500LBS RF

Código	DN	Ff (mm)	Ha (mm)	VI (mm)	Pf (mm)	Peso (kg)
-	1/2"	263.5	212	140	10	9.9
-	3/4"	273.0	256	200	14	15.8
-	1"	308.0	272	200	18	17.9
-	1.1/4"					
-	1.1/2"	384.2	411	260	31	39.1
-	2"	450.8	422	350	36.5	56.8

» Diseño Paso Total y ejecuciones especiales, bajo demanda

VÁLVULAS FORJADAS ANSI

COMPUERTA 4500LBS SW/NPT/BW WELDED BONNET

DOUGLAS CHERO COMPUERTA Fig. 205xWB		Clase: 4500LBS
Válvula compuerta Acero Carbono 4500LBS SW/NPT/BW Welded Bonnet		
Especificaciones		
Material	Acero carbono ASTM A105 ¹	
Presiones	4.010 p.s.i. a 454°C 11.110 p.s.i. a 38°C	
Pruebas	Hidráulica (mínima): Cuerpo 16.650 p.s.i. Asiento 12.210 p.s.i. Aire bajo el agua: Asiento 85 p.s.i.	
Normas	Construcción ASME B16.34 Socket Welding ASME B16.11 Rosca ASME B1.20.1 Butt Welding ASME B16.25	
¹ Ver lista de materiales de construcción		

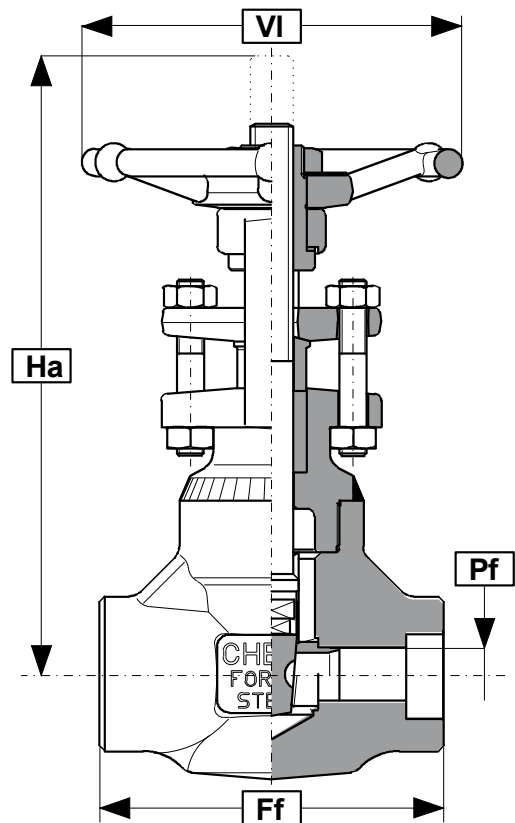
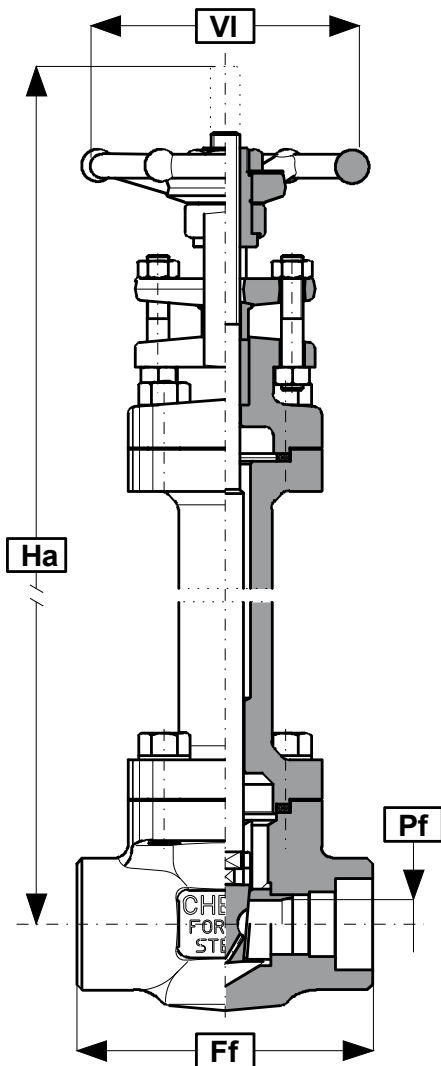

FIG. 205xWB - COMPUERTA A105/F6 TRIM N° 1 - 4500LBS SW W.B.

Código	DN	Ff (mm)	Ha (mm)	VI (mm)	Pf (mm)	Peso (kg)
-	1/2"	127	234	175	8	4.1
-	3/4"	127	259	200	11	6.2
-	1"	130	323	260	15	11.8
-	1.1/4"					
-	1.1/2"	240	431	350	25	28.0
-	2"	240	486	350	30	42.0

» Diseño Paso Total y ejecuciones especiales, bajo demanda

COMPUERTA 800LBS SW/NPT CRIOGÉNICA BOLTED BONNET



DOUGLAS CHERO COMPUERTA Fig. CR35xB		Clase: 800LBS
Válvula Compuerta Acero Carbono 800LBS SW/NPT Criogénica Bolted Bonnet		
Especificaciones		
Material	Acero carbono ASTM A105 ¹	
Presiones	800 p.s.i. a 454°C 1.975 p.s.i. a 38°C	
Pruebas	Hidráulica (mínima): Cuerpo 3.000 p.s.i. Asiento 2.175 p.s.i. Aire bajo el agua: Asiento 85 p.s.i.	
Normas	Construcción API 602, ISO 15761 Socket Welding ASME B16.11 Rosca ASME B1.20.1	
¹ Ver lista de materiales de construcción		

FIG. CR35xB - COMPUERTA A105/F6 TRIM N° 1 - 800LBS SW CRIOGÉNICA B.B.

Código	DN	Ff (mm)	Ha (mm)	VI (mm)	Pf (mm)	Peso (kg)
-	1/2"	80	333	90	10	3.1
-	3/4"	90	367	90	14	3.6
-	1"	110	406	100	18	5.7
-	1.1/4"	127	463	120	24	8.8
-	1.1/2"	127	508	140	31	11.7
-	2"	130	534	140	36.5	14.4

» Diseño Paso Total y ejecuciones especiales, bajo demanda

VÁLVULAS FORJADAS ANSI

COMPUERTA 800LBS SW/NPT CRIOGÉNICA WELDED BONNET

DOUGLAS CHERO COMPUERTA Fig. CR25x		Clase: 800LBS
Válvula Compuerta Acero Carbono 800LBS SW/NPT Criogénica Welded Bonnet		
Especificaciones		
Material	Acero carbono ASTM A105 ¹	
Presiones	800 p.s.i. a 454°C 1.975 p.s.i. a 38°C	
Pruebas	Hidráulica (mínima): Cuerpo 3.000 p.s.i. Asiento 2175 p.s.i. Aire bajo el agua: Asiento 85 p.s.i.	
Normas	Construcción API 602, ISO 15761 Socket Welding ASME B16.11 Rosca ASME B1.20.1	
¹ Ver lista de materiales de construcción		

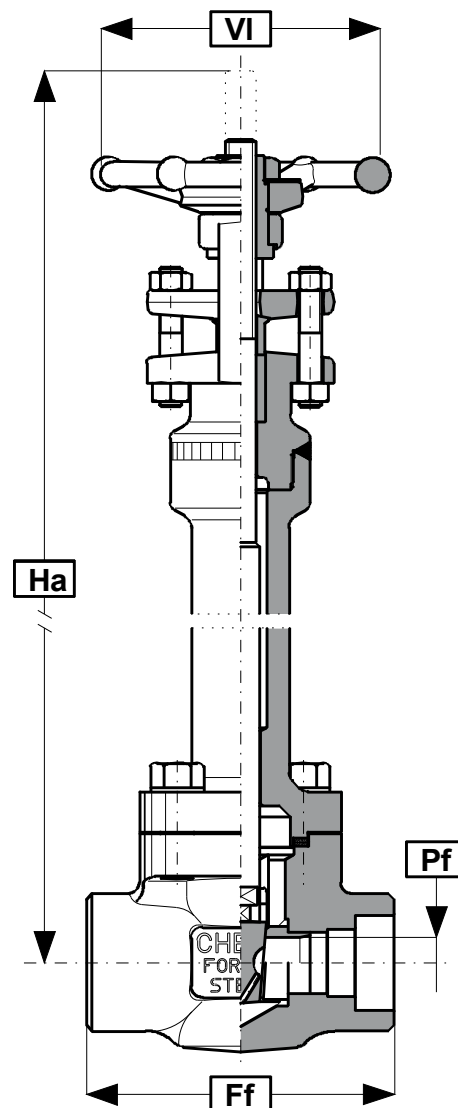
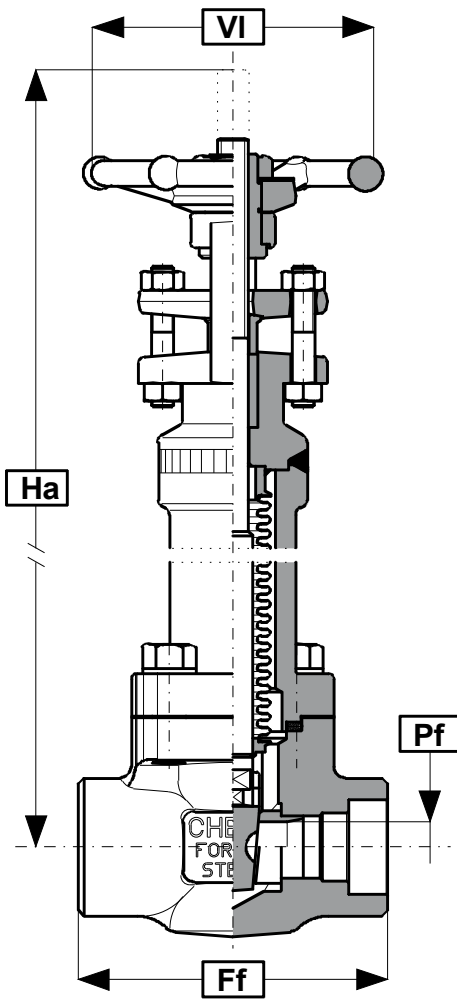

FIG. CR25x - COMPUERTA A105/F6 TRIM Nº 1 - 800LBS SW CRIOGÉNICA W.B.

Código	DN	Ff (mm)	Ha (mm)	VI (mm)	Pf (mm)	Peso (kg)
-	1/2"	80	333	90	10	3.1
-	3/4"	90	367	90	14	3.6
-	1"	110	406	100	18	5.7
-	1.1/4"	127	463	120	24	8.8
-	1.1/2"	127	508	140	31	11.7
-	2"	130	534	140	36.5	14.4

» Diseño Paso Total y ejecuciones especiales, bajo demanda

COMPUERTA 800LBS SW/NPT FUELLE BOLTED BONNET



DOUGLAS CHERO COMPUERTA Fig. SR25xB		Clase: 800LBS
Válvula Compuerta Acero Carbono 800LBS SW/NPT Fuelle Bolted Bonnet		
Especificaciones		
Material	Acero carbono ASTM A105 ¹	
Presiones	800 p.s.i. a 454°C 1.444 p.s.i. a 38°C	
Pruebas	Hidráulica (mínima): Cuerpo 2.180 p.s.i. Asiento 1.495 p.s.i. Aire bajo el agua: Asiento 85 p.s.i.	
Normas	Construcción ISO 15761 Socket Welding ASME B16.11 Rosca ASME B1.20.1	
¹ Ver lista de materiales de construcción		

FIG. SR25xB - COMPUERTA A105/F6 TRIM Nº 1 - 800LBS SW CON FUELLE B.B.

Código	DN	Ff (mm)	Ha (mm)	VI (mm)	Pf (mm)	Peso (kg)
-	1/2"	80	333	90	10	3.1
-	3/4"	90	367	90	14	3.6
-	1"	110	406	100	18	5.7
-	1.1/4"	127	463	120	24	8.8
-	1.1/2"	127	508	140	31	11.7
-	2"	130	534	140	36.5	14.4

» Diseño Paso Total y ejecuciones especiales, bajo demanda

VÁLVULAS FORJADAS ANSI

COMPUERTA 800LBS SW/NPT FUELLE WELDED BONNET

DOUGLAS CHERO COMPUERTA Fig. SR25x		Clase: 800LBS
Válvula Compuerta Acero Carbono 800LBS SW/NPT Fuelle Welded Bonnet		
Especificaciones		
Material	Acero carbono ASTM A105 ¹	
Presiones	800 p.s.i. a 454°C 1.444 p.s.i. a 38°C	
Pruebas	Hidráulica (mínima): Cuerpo 2.180 p.s.i. Asiento 1.495 p.s.i. Aire bajo el agua: Asiento 85 p.s.i.	
Normas	Construcción ISO 15761 Socket Welding ASME B16.11 Rosca ASME B1.20.1	
¹ Ver lista de materiales de construcción		

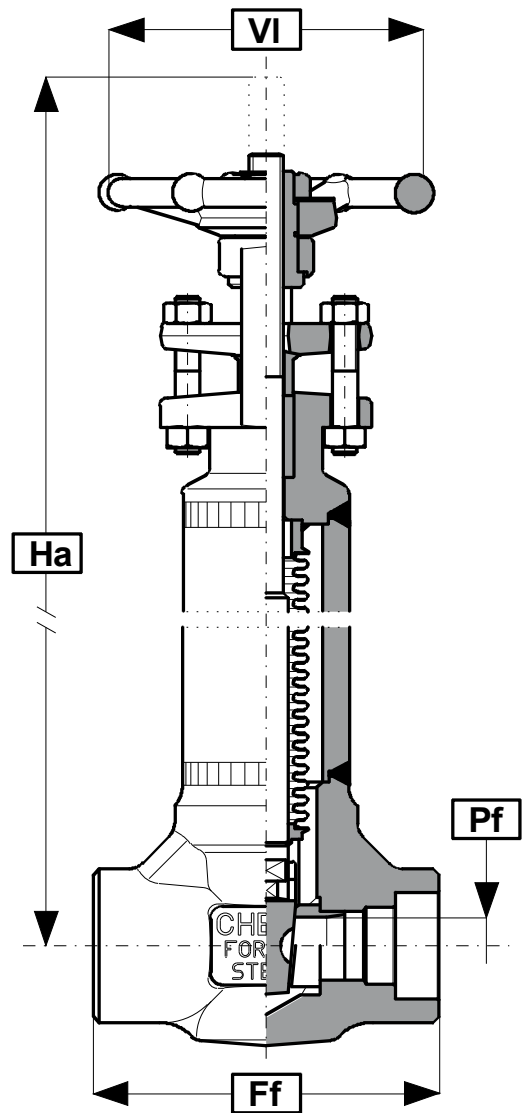
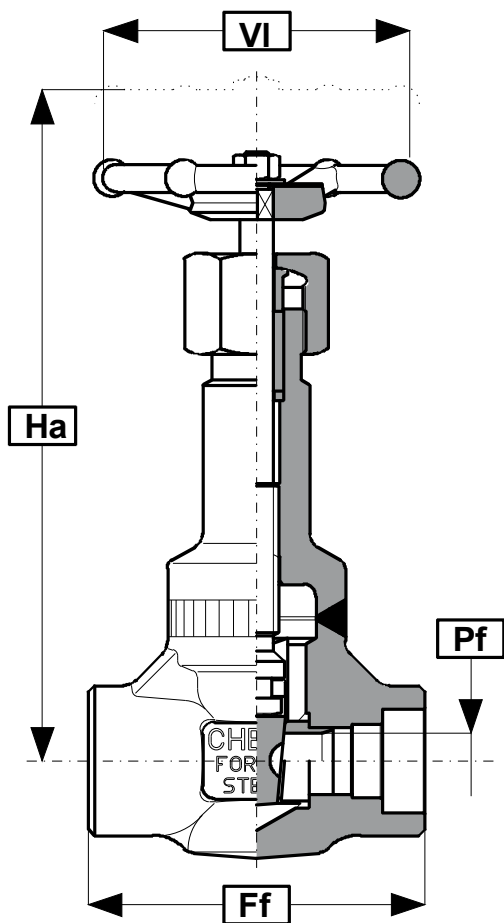

FIG. SR25x - COMPUERTA A105/F6 TRIM N° 1 - 800LBS SW CON FUELLE W.B.

Código	DN	Ff (mm)	Ha (mm)	VI (mm)	Pf (mm)	Peso (kg)
-	1/2"	80	256	90	10	2.7
-	3/4"	90	267	90	14	3.1
-	1"	110	300	100	18	4.7
-	1.1/4"	127	344	120	24	6.9
-	1.1/2"	127	421	140	31	9.5
-	2"	130	433	140	36.5	12.6

» Diseño Paso Total y ejecuciones especiales, bajo demanda

COMPUERTA 800LBS SW/NPT ISRS WELDED BONNET



DOUGLAS CHERO COMPUERTA Fig. IR25xWF		Clase: 800LBS
Válvula Compuerta Acero Carbono 800LBS SW/NPT ISRS ² Welded Bonnet		
Especificaciones		
Material	Acero carbono ASTM A105 ¹	
Presiones	800 p.s.i. a 454°C 1.975 p.s.i. a 38°C	
Pruebas	Hidráulica (mínima): Cuerpo 3.000 p.s.i. Asiento 2.175 p.s.i. Aire bajo el agua: Asiento 85 p.s.i.	
Normas	Construcción API 602, ISO 15761 Socket Welding ASME B16.11 Rosca ASME B1.20.1	
¹ Ver lista de materiales de construcción ² ISRS = Inside screw, Rising stem (Husillo interior)		

FIG. SR25xWF - COMPUERTA A105/F6 TRIM N° 1 - 800LBS SW ISRS W.B.

Código	DN	Ff (mm)	Ha (mm)	VI (mm)	Pf (mm)	Peso (kg)
-	1/2"	80	158	90	10	1.5
-	3/4"	90	183	90	14	1.9
-	1"	110	201	100	18	3.2
-	1.1/4"	127	255	120	24	4.9
-	1.1/2"	127	276	140	31	6.2
-	2"	130	310	140	36.5	8.4

» Diseño Paso Total y ejecuciones especiales, bajo demanda

VÁLVULAS FORJADAS ANSI

COMPUERTA 800LBS SW/NPT/BW CUERPO EXTENDIDO BOLTED BONNET

DOUGLAS CHERO COMPUERTA Fig. R25x/N		Clase: 800LBS
Válvula Compuerta Acero Carbono 800LBS SW/NPT/BW Cuerpo Extendido B.B.		
Especificaciones		
Material	Acero carbono ASTM A105 ¹	
Presiones	800 p.s.i. a 454°C 1.975 p.s.i. a 38°C	
Pruebas	Hidráulica (mínima): Cuerpo 3.000 p.s.i. Asiento 2.175 p.s.i. Aire bajo el agua: Asiento 85 p.s.i.	
Normas	Construcción API 602, API 606 Socket Welding ASME B16.11 Rosca ASME B1.20.1 Butt Welding ASME B16.25	
¹ Ver lista de materiales de construcción		

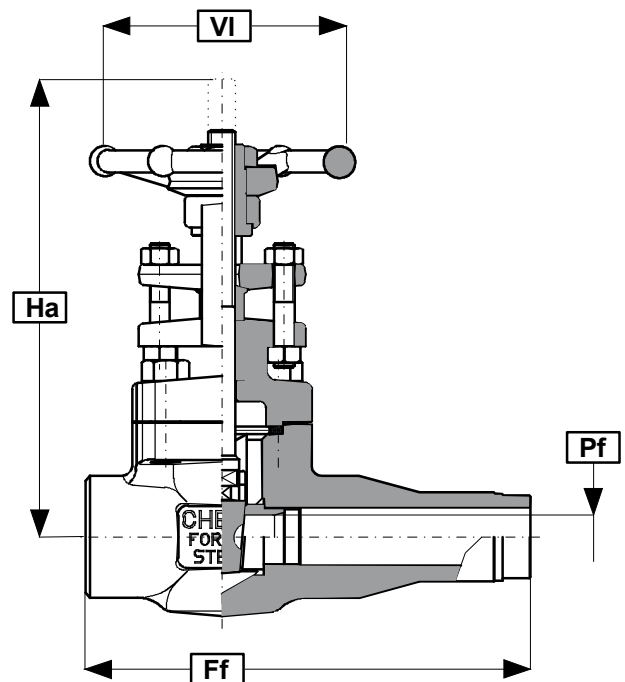

FIG. R25x/N - COMPUERTA A105/F6 TRIM N° 1 - 800LBS SW CUERPO EXTENDIDO B.B.

Código	DN	Ff (mm)	Ha (mm)	VI (mm)	Pf (mm)	Peso (kg)
-	1/2"	145	145	90	10	1.9
-	3/4"	160	156	90	14	2.4
-	1"	190	186	100	18	3.8
-	1.1/4"					
-	1.1/2"	224	255	140	31	7.7
-	2"	240	273	140	36.5	7.7

FIG. R25x/N - COMPUERTA A105/F6 U TRIM N° 5 - 800LBS SW CUERPO EXTENDIDO B.B.

Código	DN	Ff (mm)	Ha (mm)	VI (mm)	Pf (mm)	Peso (kg)
-	1/2"	145	145	90	10	1.9
-	3/4"	160	156	90	14	2.4
-	1"	190	186	100	18	3.8
-	1.1/4"					
-	1.1/2"	224	255	140	31	7.7
-	2"	240	273	140	36.5	7.7

COMPUERTA 800LBS SW/NPT/BW CUERPO EXTENDIDO W.B.

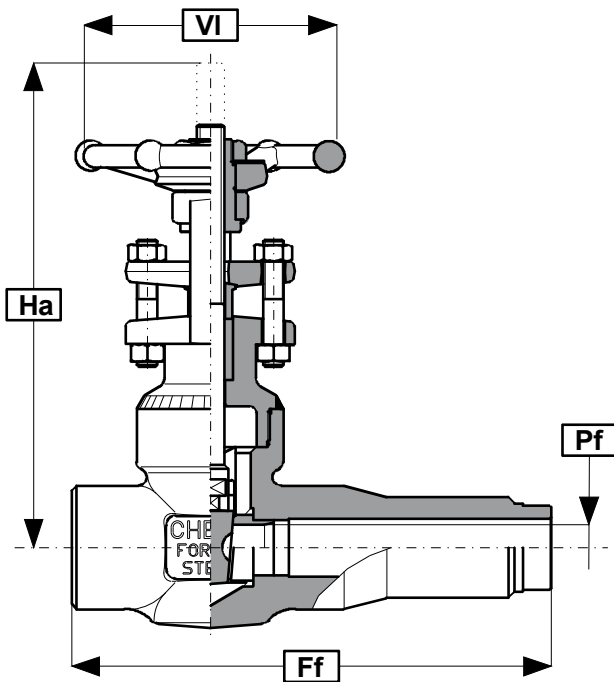

DOUGLAS CHERO COMPUERTA Fig. R25xWB/N		Clase: 800LBS
Válvula Compuerta Acero Carbono 800LBS SW/NPT/BW Cuerpo Extendido W.B.		
Especificaciones		
Material	Acero carbono ASTM A105 ¹	
Presiones	800 p.s.i. a 454°C 1.975 p.s.i. a 38°C	
Pruebas	Hidráulica (mínima): Cuerpo 3.000 p.s.i. Asiento 2.175 p.s.i. Aire bajo el agua: Asiento 85 p.s.i.	
Normas	Construcción API 602, API 606 Socket Welding ASME B16.11 Rosca ASME B1.20.1 Butt Welding ASME B16.25	
¹ Ver lista de materiales de construcción		

FIG. R25xWB/N - COMPUERTA A105/F6 TRIM N° 1 - 800LBS SW CUERPO EXTENDIDO W.B.

Código	DN	Ff (mm)	Ha (mm)	VI (mm)	Pf (mm)	Peso (kg)
-	1/2"	145	150	90	10	1.6
010102304040589	3/4"	160	157	90	14	2.0
-	1"	190	188	100	18	3.2
-	1.1/4"					
-	1.1/2"	224	248	140	31	6.2
-	2"	240	273	140	36.5	8.3

FIG. R25xWB/N - COMPUERTA A105/F6 U TRIM N° 5 - 800LBS SW CUERPO EXTENDIDO W.B.

Código	DN	Ff (mm)	Ha (mm)	VI (mm)	Pf (mm)	Peso (kg)
-	1/2"	145	150	90	10	1.6
-	3/4"	160	157	90	14	2.0
010102304041567	1"	190	188	100	18	3.2
-	1.1/4"					
-	1.1/2"	224	248	140	31	6.2
-	2"	240	273	140	36.5	8.3

VÁLVULAS FORJADAS ANSI

COMPUERTA 800LBS SW/NPT-WELD "EXTENDED WELD" B.B.

DOUGLAS CHERO COMPUERTA Fig. R25x/NW		Clase: 800LBS
Válvula Compuerta Acero Carbono 800LBS SW/NPT-Weld "Extended Weld" B.B.		
Especificaciones		
Material	Acero carbono ASTM A105 ¹	
Presiones	800 p.s.i. a 454°C 1.975 p.s.i. a 38°C	
Pruebas	Hidráulica (mínima): Cuerpo 3.000 p.s.i. Asiento 2.175 p.s.i. Aire bajo el agua: Asiento 85 p.s.i.	
Normas	Construcción API 602, API 606 Socket Welding ASME B16.11 Rosca ASME B1.20.1	
¹ Ver lista de materiales de construcción		

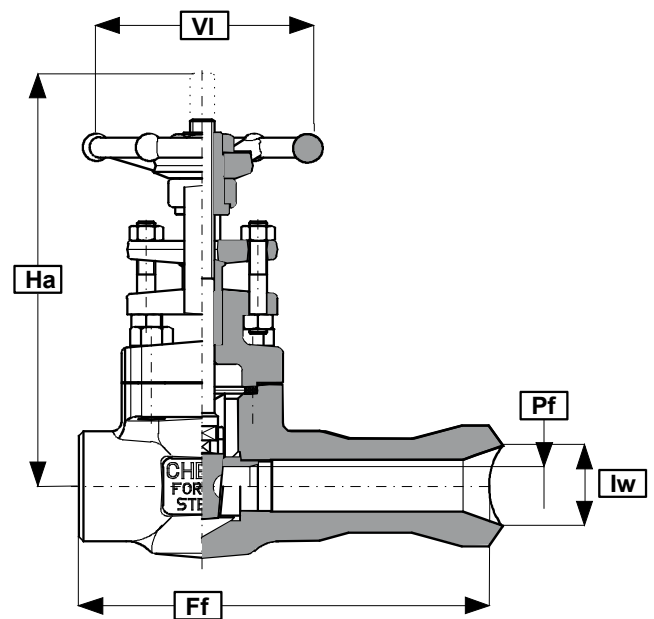
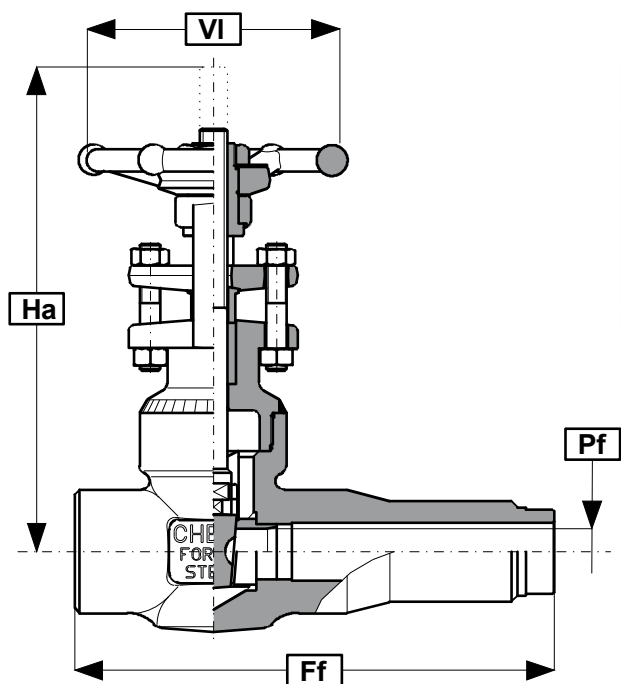

FIG. R25x/NW - COMPUERTA A105/F6 TRIM N° 1 - 800LBS SW "EXTENDED WELD" B.B.

Código	DN	Ff (mm)	Ha (mm)	VI (mm)	Pf (mm)	lw (mm)	Peso (kg)
-	1/2"	208	208	90	10	22	2.5
-	3/4"	218	156	90	14	30	2.8
-	1"	244	186	100	18	36	5.0
-	1.1/4"						
-	1.1/2"	263	255	140	31	50	9.8
-	2"	268	273	140	36.5	65	13.5

COMPUERTA 800LBS SW/NPT-WELD "EXTENDED WELD" W.B.



DOUGLAS CHERO COMPUERTA Fig. R25xWB/NW		Clase: 800LBS
Válvula Compuerta Acero Carbono 800LBS SW/NPT-WELD "Extended Weld" W.B.		
Especificaciones		
Material	Acero carbono ASTM A105 ¹	
Presiones	800 p.s.i. a 454°C 1.975 p.s.i. a 38°C	
Pruebas	Hidráulica (mínima): Cuerpo 3.000 p.s.i. Asiento 2.175 p.s.i. Aire bajo el agua: Asiento 85 p.s.i.	
Normas	Construcción API 602, API 606 Socket Welding ASME B16.11 Rosca ASME B1.20.1	
¹ Ver lista de materiales de construcción		

FIG. R25xWB/NW - COMPUERTA A105/F6 TRIM Nº 1 - 800LBS SW "EXTENDED WELDED" W.B.

Código	DN	Ff (mm)	Ha (mm)	VI (mm)	Pf (mm)	lw (mm)	Peso (kg)
-	1/2"	208	150	90	10	22	2.2
-	3/4"	218	157	90	14	30	2.5
-	1"	244	188	100	18	36	4.7
-	1.1/4"						
-	1.1/2"	263	248	140	31	50	9.0
-	2"	268	274	140	36.5	65	12.7

VÁLVULAS FORJADAS ANSI

COMPUERTA 800LBS SW/NPT LANTERN RING WELDED BONNET

DOUGLAS CHERO COMPUERTA Fig. LR25xWB		Clase: 800LBS
Válvula Compuerta Acero Carbono 800LBS SW/NPT Lantern Ring W.B.		
Especificaciones		
Material	Acero carbono ASTM A105 ¹	
Presiones	800 p.s.i. a 454°C 1.975 p.s.i. a 38°C	
Pruebas	Hidráulica (mínima): Cuerpo 3.000 p.s.i. Asiento 2.175 p.s.i. Aire bajo el agua: Asiento 85 p.s.i.	
Normas	Construcción API 602, ISO 15761 Socket Welding ASME B16.11 Rosca ASME B1.20.1	
¹ Ver lista de materiales de construcción		

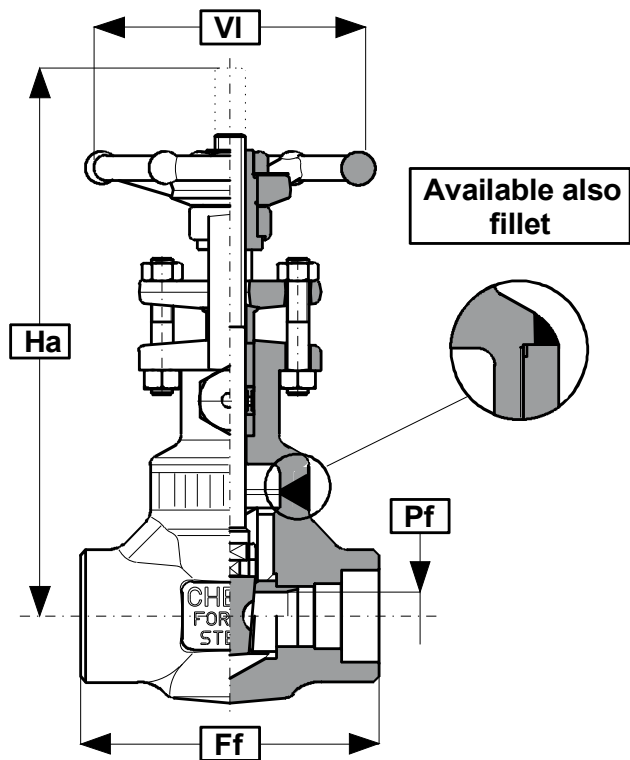
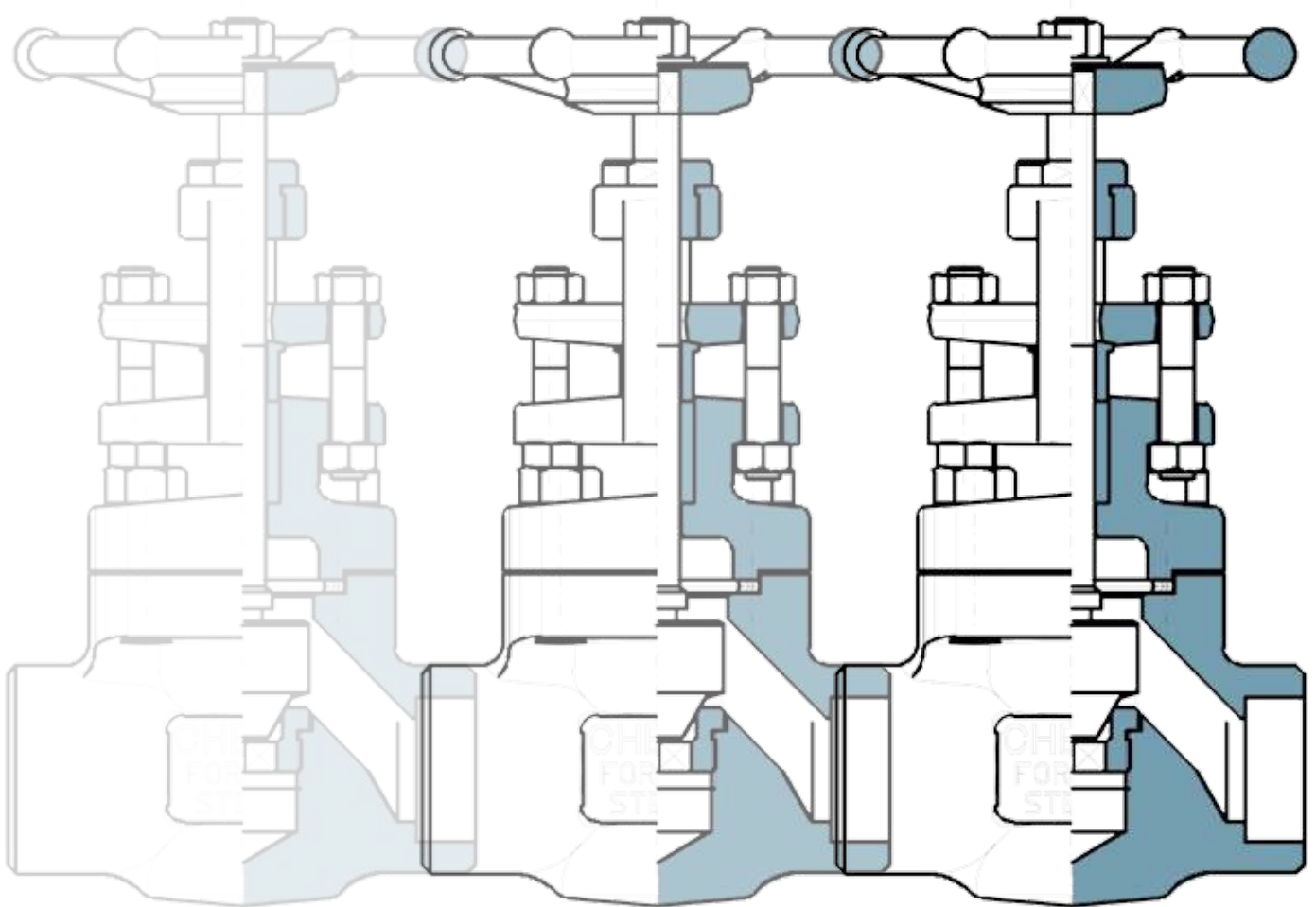

FIG. LR25xWB - COMPUERTA A105/F6 TRIM N° 1 - 800LBS SW LANTERN RING W.B.

Código	DN	Ff (mm)	Ha (mm)	VI (mm)	Pf (mm)	Peso (kg)
-	1/2"	80	164	90	10	1.6
-	3/4"	90	171	90	14	1.9
-	1"	110	204	100	18	3.1
-	1.1/4"	127	240	120	24	4.2
-	1.1/2"	127	268	140	31	6.1
-	2"	130	296	140	36.5	8.2

» Diseño Paso Total y ejecuciones especiales, bajo demanda



GLOBEVALVES

VÁLVULAS FORJADAS ANSI

GLOBO 800LBS SW/NPT/BW BOLTED BONNET

DOUGLAS CHERO Globo Fig. R35x		Clase: 800LBS
Válvula Globo Acero Carbono 800LBS SW/NPT/BW		
Especificaciones		
Material	Acero carbono ASTM A105 ¹	
Presiones	800 p.s.i. a 454°C 1.975 p.s.i. a 38°C	
Pruebas	Hidráulica (mínima): Cuerpo 3.000 p.s.i. Asiento 2.175 p.s.i. Aire bajo el agua: Asiento 85 p.s.i.	
Normas	Construcción ISO 15761 Socket Welding ASME B16.11 Rosca ASME B1.20.1 Butt Welding ASME B16.25	
¹ Ver lista de materiales de construcción		

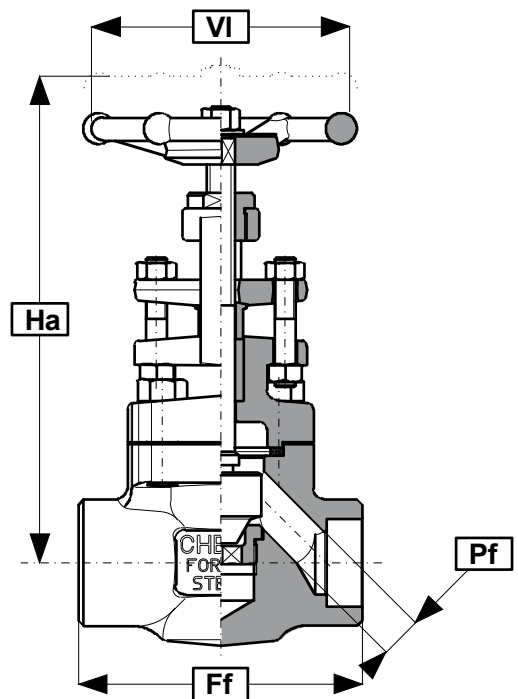

FIG. R35x - GLOBO A105/F6 TRIM N° 1 - 800LBS SW

Código	DN	Ff (mm)	Ha (mm)	VI (mm)	Pf (mm)	Peso (kg)
010102304040650	1/2"	80	152	90	9	1.7
010102304040631	3/4"	90	159	90	12.5	2
010102304040620	1"	110	182	100	17.5	3.2
010102304040629	1.1/4"	127	214	120	22.5	5.3
010102304040639	1.1/2"	155	283	140	28 ¹	7.8
010102304040627	2"	170	306	140	32 ²	10.6

FIG. R35x - GLOBO A105/F6 U TRIM N° 5 - 800LBS SW

Código	DN	Ff (mm)	Ha (mm)	VI (mm)	Pf (mm)	Peso (kg)
010102304040625	1/2"	80	152	90	9	1.7
010102304040624	3/4"	90	159	90	12.5	2
010102304040623	1"	110	182	100	17.5	3.2
010102304040468	1.1/4"	127	214	120	22.5	5.3
010102304040454	1.1/2"	155	283	140	28 ¹	7.8
010102304040626	2"	170	306	140	32 ²	10.6

FIG. R35x - GLOBO A105/F316 TRIM N° 10 - 800LBS SW

Código	DN	Ff (mm)	Ha (mm)	VI (mm)	Pf (mm)	Peso (kg)
010102304040622	1/2"	80	152	90	9	1.7
010102304040464	3/4"	90	159	90	12.5	2
010102304040455	1"	110	182	100	17.5	3.2
-	1.1/4"	127	214	120	22.5	5.3
010102304040456	1.1/2"	155	283	140	28 ¹	7.8
-	2"	170	306	140	32 ²	10.6

FIG. R35x - GLOBO A105/F6 TRIM N° 1 - 800LBS NPT

Código	DN	Ff (mm)	Ha (mm)	Vi (mm)	Pf (mm)	Peso (kg)
010102304040465	1/2"	80	152	90	9	1.7
010102304040482	3/4"	90	159	90	12.5	2
010102304040467	1"	110	182	100	17.5	3.2
010102304040453	1.1/4"	127	214	120	22.5	5.3
010102304040469	1.1/2"	155	283	140	28 ¹	7.8
010102304040470	2"	170	306	140	32 ²	10.6

FIG. R35x - GLOBO A105/F6 U TRIM N° 5 - 800LBS NPT

Código	DN	Ff (mm)	Ha (mm)	Vi (mm)	Pf (mm)	Peso (kg)
010102304040475	1/2"	80	152	90	9	1.7
010102304040471	3/4"	90	159	90	12.5	2
010102304040472	1"	110	182	100	17.5	3.2
-	1.1/4"	127	214	120	22.5	5.3
-	1.1/2"	155	283	140	28 ¹	7.8
-	2"	170	306	140	32 ²	10.6

» Diseño Paso Total y ejecuciones especiales, bajo demanda

¹ Pf = 29.5 con asientos estrellados integrales

² Pf = 35.0 con asientos estrellados integrales

VÁLVULAS FORJADAS ANSI

GLOBO 800LBS SW/NPT/BW WELDED BONNET

DOUGLAS CHERO Globo Fig. R35xWB		Clase: 800LBS
Válvula Globo Acero Carbono 800LBS SW/NPT/BW Welded Bonnet		
Especificaciones		
Material	Acero carbono ASTM A105 ¹	
Presiones	800 p.s.i. a 454°C 1.975 p.s.i. a 38°C	
Pruebas	Hidráulica (mínima): Cuerpo 3.000 p.s.i. Asiento 2.175 p.s.i. Aire bajo el agua: Asiento 85 p.s.i.	
Normas	Construcción ISO 15761 Socket Welding ASME B16.11 Rosca ASME B1.20.1 Butt Welding ASME B16.25	
¹ Ver lista de materiales de construcción		

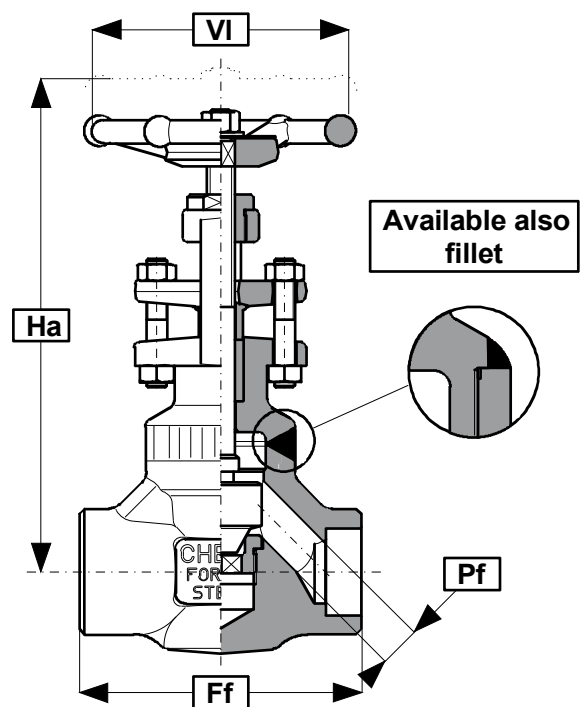

FIG. R35xWB - GLOBO A105/F6 TRIM N° 1 - 800LBS SW W.B.

Código	DN	Ff (mm)	Ha (mm)	VI (mm)	Pf (mm)	Peso (kg)
-	1/2"	80	153	90	9	1.4
-	3/4"	90	158	90	12.5	1.6
-	1"	110	179	100	17.5	3.0
-	1.1/4"	127	220	120	22.5	4.8
-	1.1/2"	155	250	140	28 ¹	6.8
-	2"	170	274	140	32 ²	9.4

FIG. R35xWB - GLOBO A105/F6 U TRIM N° 5 - 800LBS SW W.B.

Código	DN	Ff (mm)	Ha (mm)	VI (mm)	Pf (mm)	Peso (kg)
-	1/2"	80	153	90	9	1.4
-	3/4"	90	158	90	12.5	1.6
-	1"	110	179	100	17.5	3.0
-	1.1/4"	127	220	120	22.5	4.8
-	1.1/2"	155	250	140	28 ¹	6.8
-	2"	170	274	140	32 ²	9.4

» Diseño Paso Total y ejecuciones especiales, bajo demanda

¹ Pf = 29.5 con asientos estrellados integrales

² Pf = 35.0 con asientos estrellados integrales

GLOBO 150LBS RF BOLTED BONNET

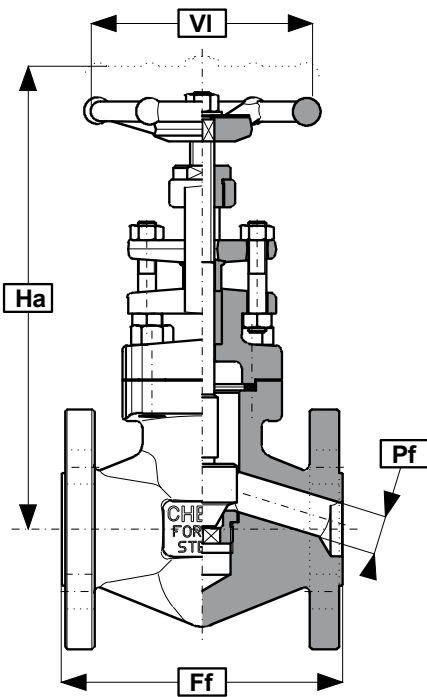

DOUGLAS CHERO Globo Fig. R35x/15		Clase: 150LBS
Válvula Globo Acero Carbono 150LBS RF		
Especificaciones		
Material	Acero carbono ASTM A105 ¹	
Presiones	150 p.s.i. a 288°C 285 p.s.i. a 38°C	
Pruebas	Hidráulica (mínima): Cuerpo 450 p.s.i. Asiento 325 p.s.i. Aire bajo el agua: Asiento 85 p.s.i.	
Normas	Construcción ISO 15761 Bridas ASME B16.5, ASME B16.10	
¹ Ver lista de materiales de construcción		

FIG. R35x/15 - GLOBO A105/F6 TRIM N° 1 - 150LBS RF

Código	DN	Ff (mm)	Ha (mm)	VI (mm)	Pf (mm)	Peso (kg)
010102304042908	1/2"	107.9	186	90	9	3.1
-	3/4"	177.5	189	90	12.5	4.0
-	1"	127.0	203	100	17.5	5.7
-	1.1/4"					
010102304042851	1.1/2"	165.1	283	140	28 ¹	10.6
-	2"	203.2	314	140	32 ²	15.4

FIG. R35x/15 - GLOBO A105/F6 U TRIM N° 5 - 150LBS RF

Código	DN	Ff (mm)	Ha (mm)	VI (mm)	Pf (mm)	Peso (kg)
-	1/2"	107.9	186	90	9	3.1
010102304040441	3/4"	177.5	189	90	12.5	4.0
010102304040479	1"	127.0	203	100	17.5	5.7
-	1.1/4"					
-	1.1/2"	165.1	283	140	28 ¹	10.6
-	2"	203.2	314	140	32 ²	15.4

» Diseño Paso Total y ejecuciones especiales, bajo demanda

¹ Pf = 29.5 con asientos estrellados integrales

² Pf = 35.0 con asientos estrellados integrales

VÁLVULAS FORJADAS ANSI

GLOBO 300LBS RF BOLTED BONNET

DOUGLAS CHERO Globo Fig. R35x/30		Clase: 300LBS
Válvula Globo Acero Carbono 300LBS RF		
Especificaciones		
Material	Acero carbono ASTM A105 ¹	
Presiones	300 p.s.i. a 454°C 740 p.s.i. a 38°C	
Pruebas	Hidráulica (mínima): Cuerpo 1.125 p.s.i. Asiento 825 p.s.i. Aire bajo el agua: Asiento 85 p.s.i.	
Normas	Construcción ISO 15761 Bridas ASME B16.5, ASME B16.10	
¹ Ver lista de materiales de construcción		

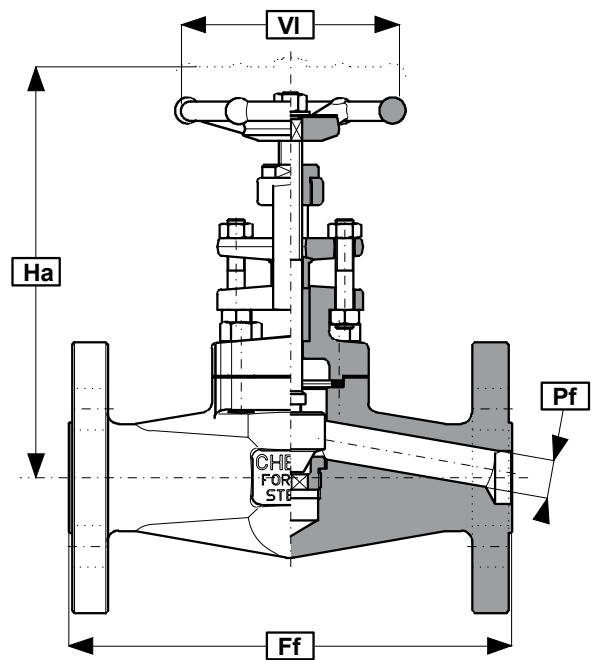

FIG. R35x/30 - GLOBO A105/F6 TRIM N° 1 - 300LBS RF

Código	DN	Ff (mm)	Ha (mm)	VI (mm)	Pf (mm)	Peso (kg)
-	1/2"	152.4	152	90	9	3.4
-	3/4"	177.8	159	90	12.5	4.8
010102304042909	1"	203.2	182	100	17.5	7.0
-	1.1/4"					
010102304042854	1.1/2"	228.6	283	140	28 ¹	14.2
-	2"	266.7	306	140	32 ²	17.4

FIG. R35x/30 - GLOBO A105/F6 U TRIM N° 5 - 300LBS RF

Código	DN	Ff (mm)	Ha (mm)	VI (mm)	Pf (mm)	Peso (kg)
010102304040478	1/2"	152.4	152	90	9	3.4
010102304040450	3/4"	177.8	159	90	12.5	4.8
010102304040449	1"	203.2	182	100	17.5	7.0
-	1.1/4"					
010102304040448	1.1/2"	228.6	283	140	28 ¹	14.2
-	2"	266.7	306	140	32 ²	17.4

» Diseño Paso Total y ejecuciones especiales, bajo demanda

¹ Pf = 29.5 con asientos estrellados integrales

² Pf = 35.0 con asientos estrellados integrales

GLOBO 600LBS RF BOLTED BONNET

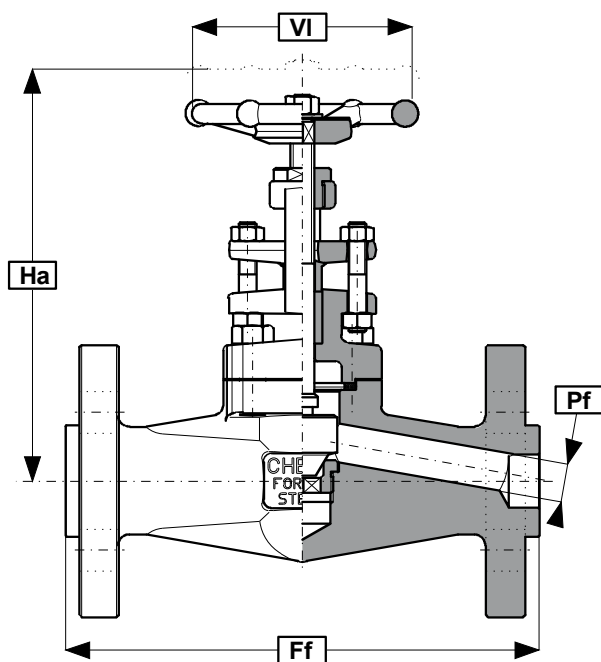

DOUGLAS CHERO Globo Fig. R35x/60		Clase: 600LBS
Válvula Globo Acero Carbono 600LBS RF		
Especificaciones		
Material	Acero carbono ASTM A105 ¹	
Presiones	600 p.s.i. a 454°C 1.480 p.s.i. a 38°C	
Pruebas	Hidráulica (mínima): Cuerpo 2.225 p.s.i. Asiento 1.650 p.s.i. Aire bajo el agua: Asiento 85 p.s.i.	
Normas	Construcción ISO 15761 Bridas ASME B16.5, ASME B16.10	
¹ Ver lista de materiales de construcción		

FIG. R35x/60 - GLOBO A105/F6 TRIM N° 1 - 600LBS RF

Código	DN	Ff (mm)	Ha (mm)	Vf (mm)	Pf (mm)	Peso (kg)
010102304042913	1/2"	165.1	152	90	9	3.6
010102304042863	3/4"	190.5	159	90	12.5	5.1
010102304042848	1"	215.9	182	100	17.5	7.8
-	1.1/4"					
-	1.1/2"	241.3	283	140	28 ¹	14.2
-	2"	292.1	306	140	32 ²	19.4

FIG. R35x/60 - GLOBO A105/F6 U TRIM N° 5 - 600LBS RF

Código	DN	Ff (mm)	Ha (mm)	Vf (mm)	Pf (mm)	Peso (kg)
-	1/2"	165.1	152	90	9	3.6
-	3/4"	190.5	159	90	12.5	5.1
-	1"	215.9	182	100	17.5	7.8
-	1.1/4"					
-	1.1/2"	241.3	283	140	28 ¹	14.2
-	2"	292.1	306	140	32 ²	19.4

» Diseño Paso Total y ejecuciones especiales, bajo demanda

¹ Pf = 29.5 con asientos estrellados integrales

² Pf = 35.0 con asientos estrellados integrales

VÁLVULAS FORJADAS ANSI

GLOBO 1500LBS SW/NPT/BW BOLTED BONNET

DOUGLAS CHERO Globo Fig. 75x		Clase: 1500LBS
Válvula Globo Acero Carbono 1500LBS SW/NPT/BW		
Especificaciones		
Material	Acero carbono ASTM A105 ¹	
Presiones	1500 p.s.i. a 454°C 3.705 p.s.i. a 38°C	
Pruebas	Hidráulica (mínima): Cuerpo 5.575 p.s.i. Asiento 4.100 p.s.i. Aire bajo el agua: Asiento 85 p.s.i.	
Normas	Construcción ISO 15761 Socket Welding ASME B16.11 Rosca ASME B1.20.1 Butt Welding ASME B16.25	
¹ Ver lista de materiales de construcción		

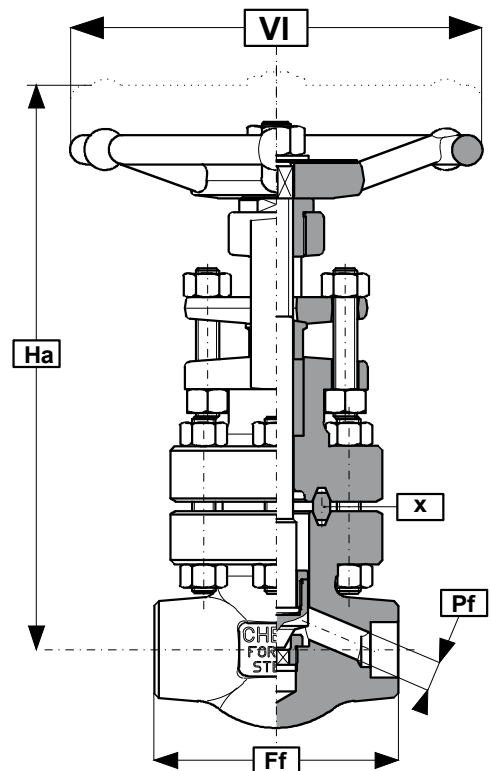

FIG. 75x - GLOBO A105/F6 TRIM N° 1 - 1500LBS SW

Código	DN	Ff (mm)	Ha (mm)	VI (mm)	Pf (mm)	Peso (kg)
-	1/2"	110	218	120	11	5.6
-	3/4"	115	274	175	14.5	8.0
010102304040648	1"	130	286	175	19	9.3
-	1.1/4"					
-	1.1/2"	210	427	260	31	26.2
-	2"	240	433	260	37.5	34.5

FIG. 75x - GLOBO A105/F6 U TRIM N° 5 - 1500LBS SW

Código	DN	Ff (mm)	Ha (mm)	VI (mm)	Pf (mm)	Peso (kg)
-	1/2"	110	218	120	11	5.6
010102304042513	3/4"	115	274	175	14.5	8.0
-	1"	130	286	175	19	9.3
-	1.1/4"					
-	1.1/2"	210	427	260	31	26.2
010102304042658	2"	240	433	260	37.5	34.5

» Diseño Paso Total y ejecuciones especiales, bajo demanda

GLOBO 1500LBS SW/NPT/BW WELDED BONNET

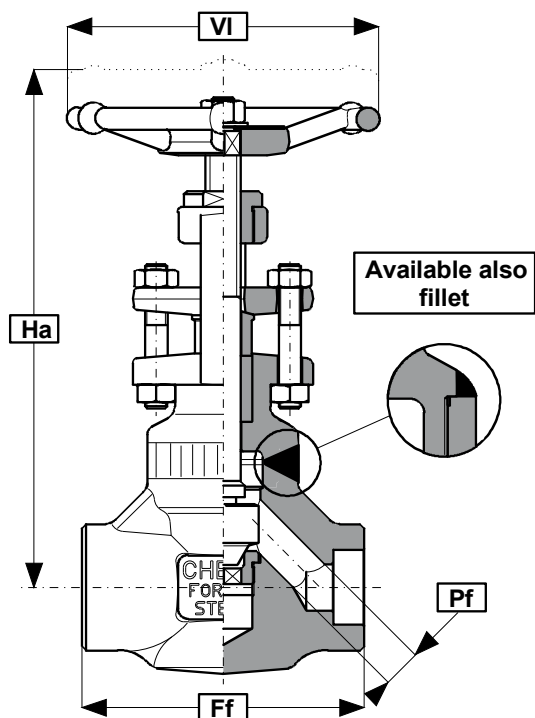

DOUGLAS CHERO Globo Fig. 75xWB		Clase: 1500LBS
Válvula Globo Acero Carbono 1500LBS SW/NPT/BW W.B.		
Especificaciones		
Material	Acero carbono ASTM A105 ¹	
Presiones	1500 p.s.i. a 454°C 3.705 p.s.i. a 38°C	
Pruebas	Hidráulica (mínima): Cuerpo 5.575 p.s.i. Asiento 4.100 p.s.i. Aire bajo el agua: Asiento 85 p.s.i.	
Normas	Construcción ISO 15761 Socket Welding ASME B16.11 Rosca ASME B1.20.1 Butt Welding ASME B16.25	
¹ Ver lista de materiales de construcción		

FIG. 75xWB - GLOBO A105/F6 TRIM N° 1 - 1500LBS SW W.B.

Código	DN	Ff (mm)	Ha (mm)	VI (mm)	Pf (mm)	Peso (kg)
-	1/2"	90	203	120	11	1.9
-	3/4"	110	227	175	14.5	3.3
-	1"	127	233	175	19	5.2
-	1.1/4"					
-	1.1/2"	170	310	200	31	10.3
-	2"	210	402	260	37.5	17.8

FIG. 75xWB - GLOBO A105/F6 U TRIM N° 5 - 1500LBS SW W.B.

Código	DN	Ff (mm)	Ha (mm)	VI (mm)	Pf (mm)	Peso (kg)
010102304040458	1/2"	90	203	120	11	1.9
010102304040461	3/4"	110	227	175	14.5	3.3
010102304040462	1"	127	233	175	19	5.2
-	1.1/4"					
010102304040463	1.1/2"	170	310	200	31	10.3
010102304042658	2"	210	402	260	37.5	17.8

» Diseño Paso Total y ejecuciones especiales, bajo demanda

VÁLVULAS FORJADAS ANSI

GLOBO 1500LBS RF BOLTED BONNET

DOUGLAS CHERO Globo Fig. 75x/150		Clase: 1500LBS
Válvula Globo Acero Carbono 1500LBS RF		
Especificaciones		
Material	Acero carbono ASTM A105 ¹	
Presiones	1.500 p.s.i. a 454°C 3.705 p.s.i. a 38°C	
Pruebas	Hidráulica (mínima): Cuerpo 5.575 p.s.i. Asiento 4.100 p.s.i. Aire bajo el agua: Asiento 85 p.s.i.	
Normas	Construcción ISO 15761 Bridas ASME B16.5, ASME B16.10	
¹ Ver lista de materiales de construcción		

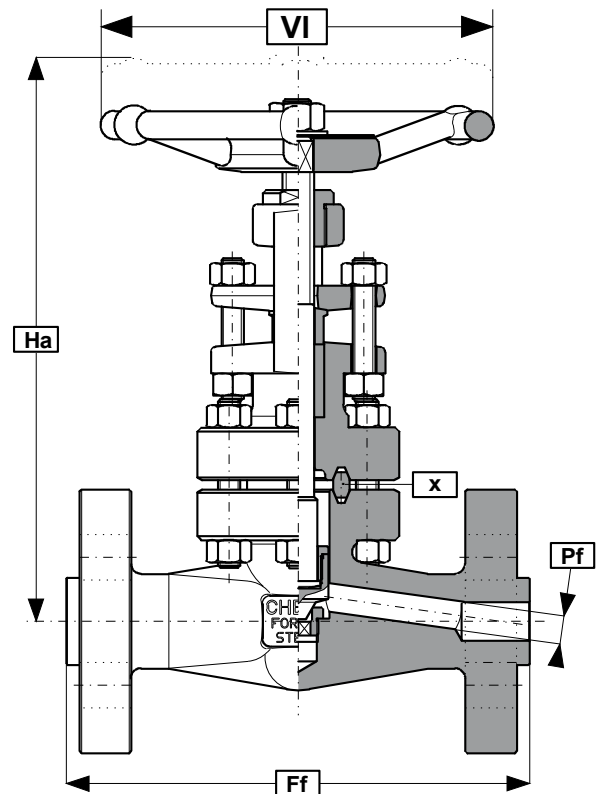

FIG. 75x/150 - GLOBO A105/F6 TRIM N° 1 - 1500LBS RF

Código	DN	Ff (mm)	Ha (mm)	VI (mm)	Pf (mm)	Peso (kg)
-	1/2"	215.9	218	120	11	9.4
-	3/4"	228.6	274	175	14.5	15.2
-	1"	254.0	286	175	19	17.3
-	1.1/4"					
-	1.1/2"	304.8	427	260	31	37.9
-	2"	368.3	433	260	37.5	55.2

FIG. 75x/150 - GLOBO A105/F6 U TRIM N° 5 - 1500LBS RF

Código	DN	Ff (mm)	Ha (mm)	VI (mm)	Pf (mm)	Peso (kg)
-	1/2"	215.9	218	120	11	9.4
-	3/4"	228.6	274	175	14.5	15.2
-	1"	254.0	286	175	19	17.3
-	1.1/4"					
-	1.1/2"	304.8	427	260	31	37.9
-	2"	368.3	433	260	37.5	55.2

» Diseño Paso Total y ejecuciones especiales, bajo demanda

GLOBO 2500LBS SW/NPT/BW BOLTED BONNET

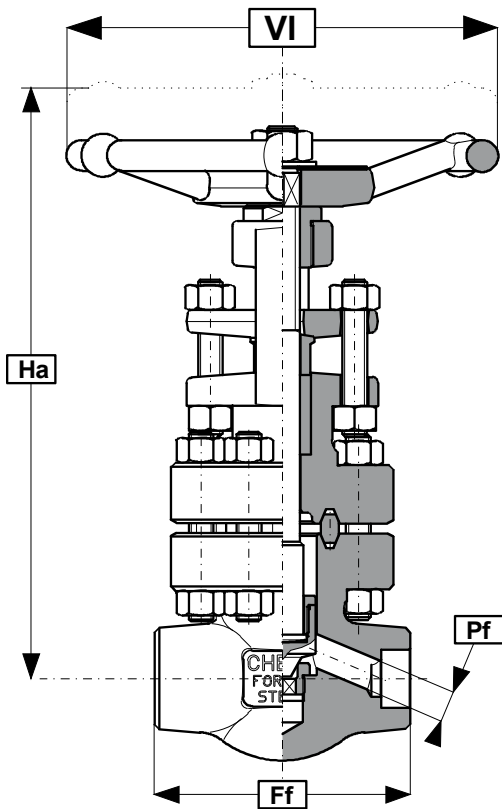

DOUGLAS CHERO Globo Fig. 105x		Clase: 2500LBS
Válvula Globo Acero Carbono 2500LBS SW/NPT/BW		
Especificaciones		
Material	Acero carbono ASTM A105 ¹	
Presiones	2.500 p.s.i. a 454°C 6.170 p.s.i. a 38°C	
Pruebas	Hidráulica (mínima): Cuerpo 9.275 p.s.i. Asiento 6.800 p.s.i. Aire bajo el agua: Asiento 85 p.s.i.	
Normas	Construcción ASME B16.34 Socket Welding ASME B16.11 Rosca ASME B1.20.1 Butt Welding ASME B16.25	
¹ Ver lista de materiales de construcción		

FIG. 105x - GLOBO A105/F6 TRIM N° 1 - 2500LBS SW

Código	DN	Ff (mm)	Ha (mm)	VI (mm)	Pf (mm)	Peso (kg)
-	1/2"	110	218	140	10	5.8
-	3/4"	115	260	200	13	8.3
-	1"	130	268	200	18	9.7
-	1.1/4"					
-	1.1/2"	210	427	260	25	26.8
-	2"	240	433	350	34	35.3

FIG. 105x - GLOBO A105/F6 U TRIM N° 5 - 2500LBS SW

Código	DN	Ff (mm)	Ha (mm)	VI (mm)	Pf (mm)	Peso (kg)
-	1/2"	110	218	140	10	5.8
-	3/4"	115	260	200	13	8.3
-	1"	130	268	200	18	9.7
-	1.1/4"					
-	1.1/2"	210	427	260	25	26.8
-	2"	240	433	350	34	35.3

» Diseño Paso Total y ejecuciones especiales, bajo demanda

VÁLVULAS FORJADAS ANSI

GLOBO 2500LBS SW/NPT/BW WELDED BONNET

DOUGLAS CHERO Globo Fig. 105xWB		Clase: 2500LBS
Válvula Globo Acero Carbono 2500LBS SW/NPT/BW Welded Bonnet		
Especificaciones		
Material	Acero carbono ASTM A105 ¹	
Presiones	2.500 p.s.i. a 454°C 6.170 p.s.i. a 38°C	
Pruebas	Hidráulica (mínima): Cuerpo 9.275 p.s.i. Asiento 6.800 p.s.i. Aire bajo el agua: Asiento 85 p.s.i.	
Normas	Construcción ASME B16.34 Socket Welding ASME B16.11 Rosca ASME B1.20.1 Butt Welding ASME B16.25	
¹ Ver lista de materiales de construcción		

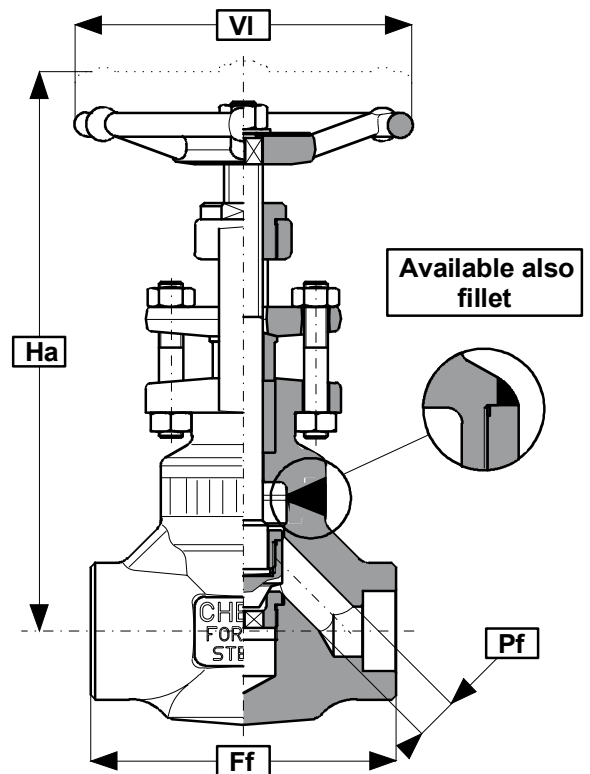

FIG. 105xWB - GLOBO A105/F6 TRIM N° 1 - 2500LBS SW W.B.

Código	DN	Ff (mm)	Ha (mm)	VI (mm)	Pf (mm)	Peso (kg)
-	1/2"	110	209	140	10	2.5
-	3/4"	127	238	200	13	4.1
-	1"	155	257	200	18	6.2
-	1.1/4"					
-	1.1/2"	210	386	260	25	11.8
-	2"	240	407	350	34	28

FIG. 105xWB - GLOBO A105/F6 U TRIM N° 5 - 2500LBS SW W.B.

Código	DN	Ff (mm)	Ha (mm)	VI (mm)	Pf (mm)	Peso (kg)
-	1/2"	110	209	140	10	2.5
-	3/4"	127	238	200	13	4.1
-	1"	155	257	200	18	6.2
-	1.1/4"					
-	1.1/2"	210	386	260	25	11.8
-	2"	240	407	350	34	28

» Diseño Paso Total y ejecuciones especiales, bajo demanda

GLOBO 2500LBS RF BOLTED BONNET

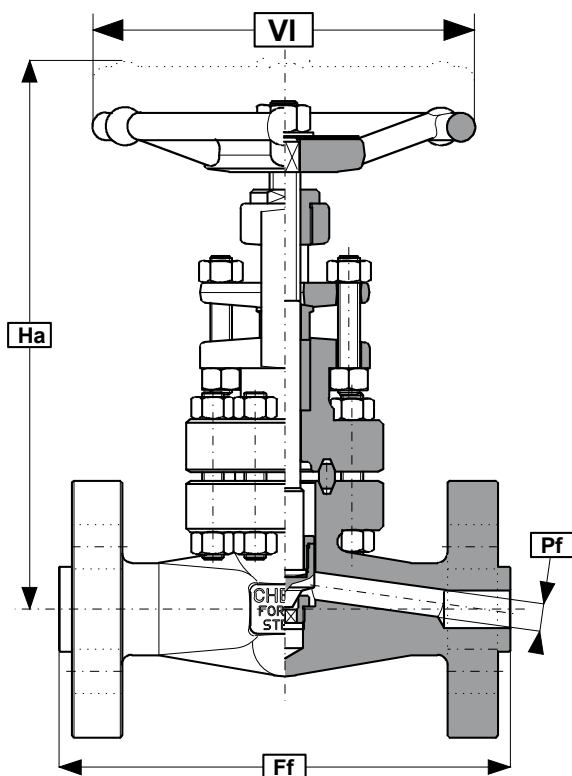

DOUGLAS CHERO Globo Fig. 105x/250		Clase: 2500LBS
Válvula Globo Acero Carbono 2500LBS RF		
Especificaciones		
Material	Acero carbono ASTM A105 ¹	
Presiones	2.500 p.s.i. a 454°C 6.170 p.s.i. a 38°C	
Pruebas	Hidráulica (mínima): Cuerpo 9.275 p.s.i. Asiento 6.800 p.s.i. Aire bajo el agua: Asiento 85 p.s.i.	
Normas	Construcción ASME B16.34 Bridas ASME B16.5, ASME B16.10	
¹ Ver lista de materiales de construcción		

FIG. 105x/250 - GLOBO A105/F6 TRIM N° 1 - 2500LBS RF

Código	DN	Ff (mm)	Ha (mm)	VI (mm)	Pf (mm)	Peso (kg)
-	1/2"	263.5	218	140	10	9.6
-	3/4"	273.0	274	200	13	15.4
-	1"	308.0	286	200	18	17.4
-	1.1/4"					
-	1.1/2"	384.2	427	260	25	38.5
-	2"	450.8	433	350	34	55.9

FIG. 105x/250 - GLOBO A105/F6 U TRIM N° 5 - 2500LBS RF

Código	DN	Ff (mm)	Ha (mm)	VI (mm)	Pf (mm)	Peso (kg)
-	1/2"	263.5	218	140	10	9.6
-	3/4"	273.0	274	200	13	15.4
-	1"	308.0	286	200	18	17.4
-	1.1/4"					
-	1.1/2"	384.2	427	260	25	38.5
-	2"	450.8	433	350	34	55.9

» Diseño Paso Total y ejecuciones especiales, bajo demanda

VÁLVULAS FORJADAS ANSI

GLOBO 4500LBS SW/NPT/BW WELDED BONNET

DOUGLAS CHERO Globo Fig. 215xWB		Clase: 4500LBS
Válvula Globo Acero Carbono 4500LBS SW/NPT/BW W.B.		
Especificaciones		
Material	Acero carbono ASTM A105 ¹	
Presiones	4.010 p.s.i. a 454°C 11.110 p.s.i. a 38°C	
Pruebas	Hidráulica (mínima): Cuerpo 16.650 p.s.i. Asiento 12.210 p.s.i. Aire bajo el agua: Asiento 85 p.s.i.	
Normas	Construcción ASME B16.34 Socket Welding ASME B16.11 Rosca ASME B1.20.1 Butt Welding ASME B16.25	
¹ Ver lista de materiales de construcción		

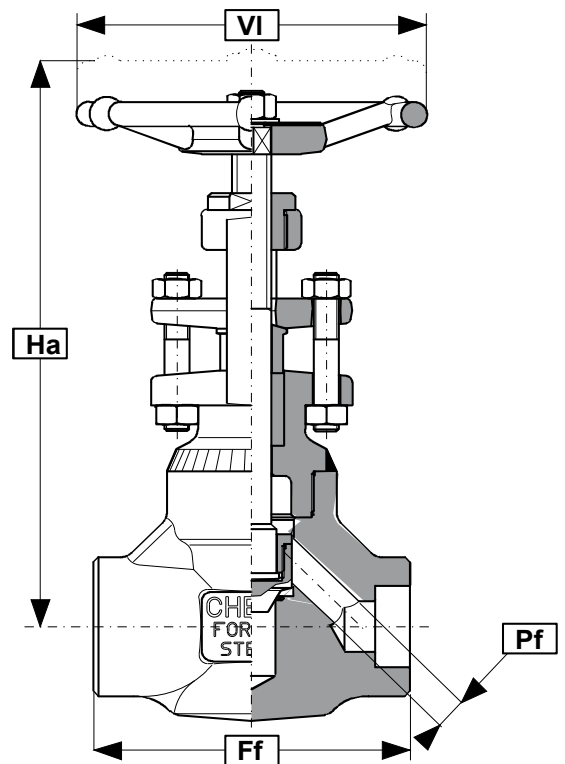

FIG. 215XWB - GLOBO A105/F6 TRIM N° 1 - 4500LBS SW W.B.

Código	DN	Ff (mm)	Ha (mm)	VI (mm)	Pf (mm)	Peso (kg)
-	1/2"	127	230	175	7	4.1
-	3/4"	155	277	200	11	6.2
-	1"	170	335	260	14	11.8
-	1.1/4"					
-	1.1/2"	240	431	350	25	28.0
-	2"	240	450	350	30	42.0

FIG. 215XWB - GLOBO A105/F6 U TRIM N° 5 - 4500LBS SW W.B.

Código	DN	Ff (mm)	Ha (mm)	VI (mm)	Pf (mm)	Peso (kg)
-	1/2"	127	230	175	7	4.1
-	3/4"	155	277	200	11	6.2
-	1"	170	335	260	14	11.8
-	1.1/4"					
-	1.1/2"	240	431	350	25	28.0
-	2"	240	450	350	30	42.0

» Diseño Paso Total y ejecuciones especiales, bajo demanda

GLOBO 800LBS SW/NPT CRIOGÉNICA

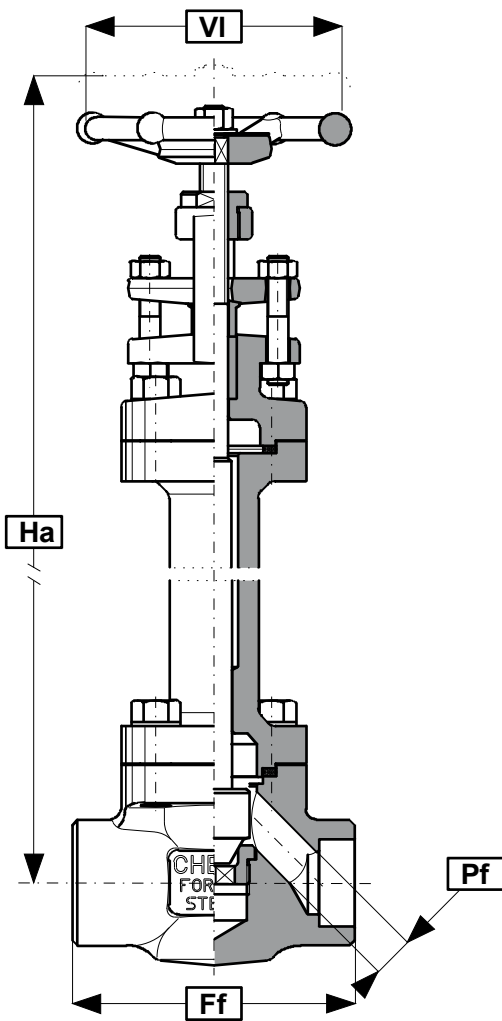

DOUGLAS CHERO Globo Fig. CR35xB		Clase: 800LBS
Válvula Globo Acero Carbono 800LBS SW/NPT Criogénica		
Especificaciones		
Material	Acero carbono ASTM A105 ¹	
Presiones	800 p.s.i. a 454°C 1.975 p.s.i. a 38°C	
Pruebas	Hidráulica (mínima): Cuerpo 3.000 p.s.i. Asiento 2.175 p.s.i. Aire bajo el agua: Asiento 85 p.s.i.	
Normas	Construcción ISO 15761 Socket Welding ASME B16.11 Rosca ASME B1.20.1	
¹ Ver lista de materiales de construcción		

FIG. CR35xB - GLOBO A105/F6 TRIM N° 1 - 800LBS SW CRIOGÉNICA

Código	DN	Ff (mm)	Ha (mm)	VI (mm)	Pf (mm)	Peso (kg)
-	1/2"	80	333	90	9	3.1
-	3/4"	90	365	90	12	3.6
-	1"	110	401	100	17.5	5.7
-	1.1/4"	127	462	120	22.5	8.8
-	1.1/2"	155	507	140	28 ¹	11.7
-	2"	170	531	140	32 ²	14.4

» Diseño Paso Total y ejecuciones especiales, bajo demanda

¹ Pf = 29.5 con asientos estrellados integrales

² Pf = 35.0 con asientos estrellados integrales

VÁLVULAS FORJADAS ANSI

GLOBO 800LBS SW/NPT CRIOGÉNICA W.B.

DOUGLAS CHERO Globo Fig. CR35x		Clase: 800LBS
Válvula Globo Acero Carbono 800LBS SW/NPT Criogénica W.B.		
Especificaciones		
Material	Acero carbono ASTM A105 ¹	
Presiones	800 p.s.i. a 454°C 1.975 p.s.i. a 38°C	
Pruebas	Hidráulica (mínima): Cuerpo 3.000 p.s.i. Asiento 2.175 p.s.i. Aire bajo el agua: Asiento 85 p.s.i.	
Normas	Construcción ISO 15761 Socket Welding ASME B16.11 Rosca ASME B1.20.1	
¹ Ver lista de materiales de construcción		

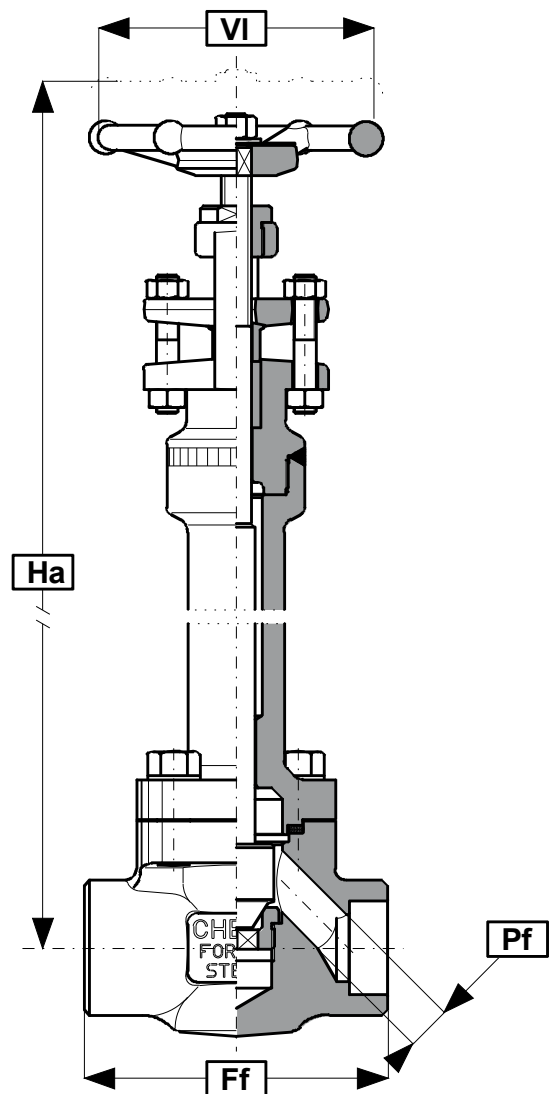

FIG. CR35x - GLOBO A105/F6 TRIM N° 1 - 800LBS SW CRIOGÉNICA W.B.

Código	DN	Ff (mm)	Ha (mm)	VI (mm)	Pf (mm)	Peso (kg)
-	1/2"	80	333	90	9.0	2.6
-	3/4"	90	365	90	12.5	3.1
-	1"	110	401	100	17.5	5.2
-	1.1/4"	127	462	120	22.5	8.6
-	1.1/2"	155	507	140	28 ¹	12.4
-	2"	170	531	140	32 ²	15.7

» Diseño Paso Total y ejecuciones especiales, bajo demanda

¹ Pf = 29.5 con asientos estrellados integrales

² Pf = 35.0 con asientos estrellados integrales

GLOBO 800LBS SW/NPT FUELLE

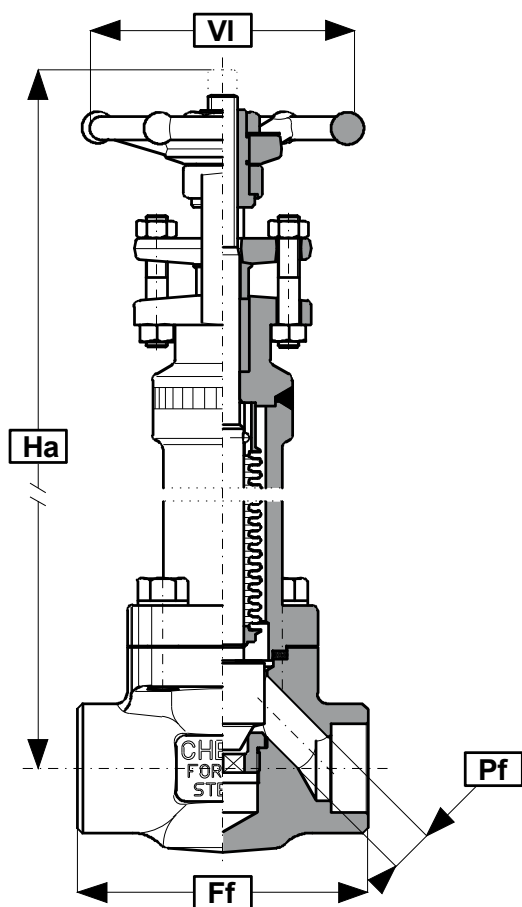

DOUGLAS CHERO Globo Fig. SR25xB		Clase: 800LBS
Válvula Globo Acero Carbono 800LBS SW/NPT Fuelle		
Especificaciones		
Material	Acero carbono ASTM A105 ¹	
Presiones	800 p.s.i. a 454°C 1.975 p.s.i. a 38°C	
Pruebas	Hidráulica (mínima): Cuerpo 2.180 p.s.i. Asiento 1.495 p.s.i. Aire bajo el agua: Asiento 85 p.s.i.	
Normas	Construcción ISO 15761 Socket Welding ASME B16.11 Rosca ASME B1.20.1	
¹ Ver lista de materiales de construcción		

FIG. SR25xB - GLOBO A105/F6 TRIM N° 1 - 800LBS SW CON FUELLE

Código	DN	Ff (mm)	Ha (mm)	VI (mm)	Pf (mm)	Peso (kg)
-	1/2"	80	234	90	9	2.5
-	3/4"	90	243	90	12.5	2.8
-	1"	110	290	100	17.5	5.2
-	1.1/4"	127	320	120	22.5	7.5
-	1.1/2"	155	363	140	28 ¹	11.4
-	2"	170	389	140	32 ²	15.4

» Diseño Paso Total y ejecuciones especiales, bajo demanda

¹ Pf = 29.5 con asientos estrellados integrales

² Pf = 35.0 con asientos estrellados integrales

VÁLVULAS FORJADAS ANSI

GLOBO 800LBS SW/NPT FUELLE W.B.

DOUGLAS CHERO Globo Fig. SR25x		Clase: 800LBS
Válvula Globo Acero Carbono 800LBS SW/NPT Fuelle W.B.		
Especificaciones		
Material	Acero carbono ASTM A105 ¹	
Presiones	800 p.s.i. a 454°C 1.975 p.s.i. a 38°C	
Pruebas	Hidráulica (mínima): Cuerpo 2.180 p.s.i. Asiento 1.495 p.s.i. Aire bajo el agua: Asiento 85 p.s.i.	
Normas	Construcción ISO 15761 Socket Welding ASME B16.11 Rosca ASME B1.20.1	
¹ Ver lista de materiales de construcción		

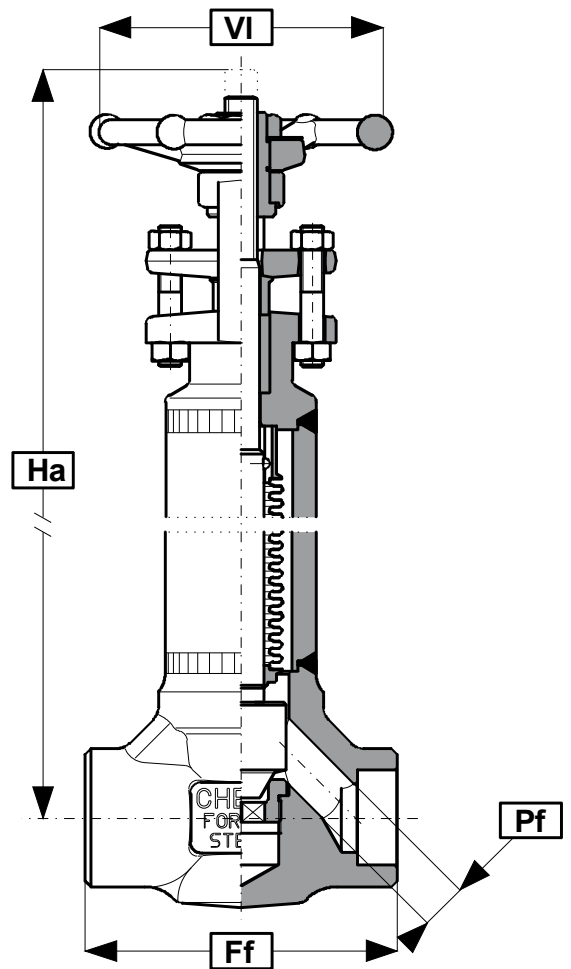

FIG. SR25x - GLOBO A105/F6 TRIM N° 1 - 800LBS SW CON FUELLE W.B.

Código	DN	Ff (mm)	Ha (mm)	VI (mm)	Pf (mm)	Peso (kg)
-	1/2"	80	235	90	9	2.3
-	3/4"	90	259	90	12.5	2.6
-	1"	110	302	100	17.5	4.3
-	1.1/4"	127	329	120	22.5	6.8
-	1.1/2"	155	354	140	28 ¹	9.6
-	2"	170	390	140	32 ²	13.8

» Diseño Paso Total y ejecuciones especiales, bajo demanda

¹ Pf = 29.5 con asientos estrellados integrales

² Pf = 35.0 con asientos estrellados integrales

GLOBO 800LBS SW/NPT ISRS

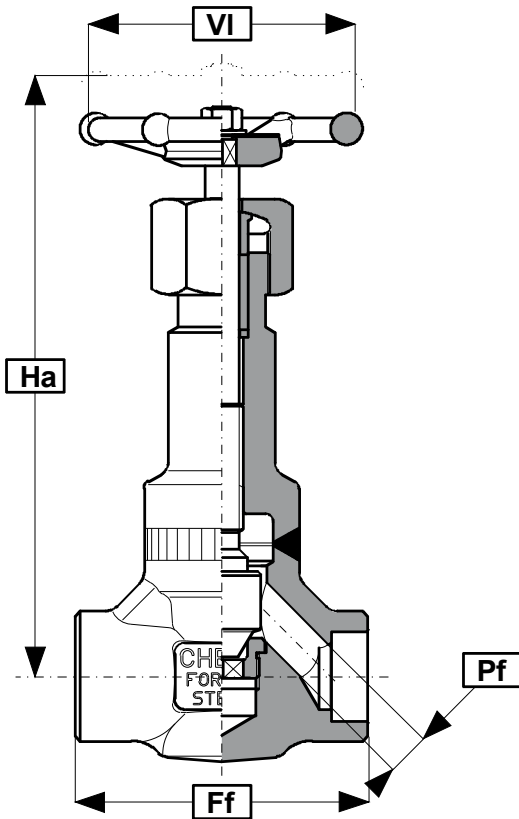

DOUGLAS CHERO Globo Fig. IR35xWF		Clase: 800LBS
Válvula Globo Acero Carbono 800LBS SW/NPT ISRS		
Especificaciones		
Material	Acero carbono ASTM A105 ¹	
Presiones	800 p.s.i. a 454°C 1.975 p.s.i. a 38°C	
Pruebas	Hidráulica (mínima): Cuerpo 3.000 p.s.i. Asiento 2.175 p.s.i. Aire bajo el agua: Asiento 85 p.s.i.	
Normas	Construcción ISO 15761 Socket Welding ASME B16.11 Rosca ASME B1.20.1	
¹ Ver lista de materiales de construcción ² ISRS = Inside screw, Rising stem (Husillo interior)		

FIG. IR35xWF - GLOBO A105/F6 TRIM N° 1 - 800LBS SW ISRS

Código	DN	Ff (mm)	Ha (mm)	VI (mm)	Pf (mm)	Peso (kg)
-	1/2"	80	162	90	9.0	1.5
-	3/4"	90	189	90	12.5	1.8
-	1"	110	222	100	17.5	3.3
-	1.1/4"	127	250	120	22.5	5.5
-	1.1/2"	155	278	140	28 ¹	8.0
-	2"	170	314	140	32 ²	10.6

» Diseño Paso Total y ejecuciones especiales, bajo demanda

¹ Pf = 29.5 con asientos estrellados integrales

² Pf = 35.0 con asientos estrellados integrales

VÁLVULAS FORJADAS ANSI

GLOBO 800LBS SW/NPT LANTERN RING W.B.

DOUGLAS CHERO Globo Fig. LR35xWB		Clase: 800LBS
Válvula Globo Acero Carbono 800LBS SW/NPT Lantern Ring W.B.		
Especificaciones		
Material	Acero carbono ASTM A105 ¹	
Presiones	800 p.s.i. a 454°C 1.975 p.s.i. a 38°C	
Pruebas	Hidráulica (mínima): Cuerpo 3.000 p.s.i. Asiento 2.175 p.s.i. Aire bajo el agua: Asiento 85 p.s.i.	
Normas	Construcción ISO 15761 Socket Welding ASME B16.11 Rosca ASME B1.20.1	
¹ Ver lista de materiales de construcción		

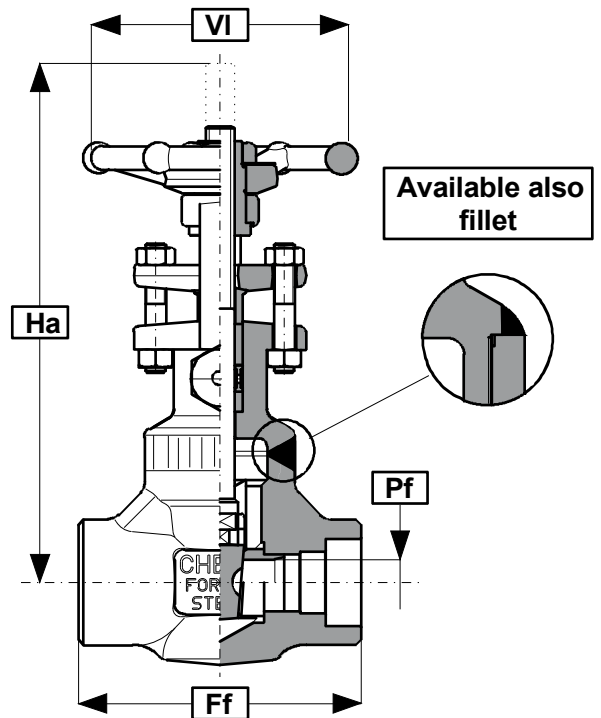

FIG. LR35xWB - GLOBO A105/F6 TRIM N° 1 - 800LBS SW LANTERN RING W.B.

Código	DN	Ff (mm)	Ha (mm)	VI (mm)	Pf (mm)	Peso (kg)
-	1/2"	80	163	90	9.0	1.6
-	3/4"	90	168	90	12.0	1.8
-	1"	110	191	100	17.5	3.3
-	1.1/4"	127	20	120	22.5	5.2
-	1.1/2"	155	262	140	28 ¹	7.1
-	2"	170	288	140	32 ²	9.9

» Diseño Paso Total y ejecuciones especiales, bajo demanda

¹ Pf = 29.5 con asientos estrellados integrales

² Pf = 35.0 con asientos estrellados integrales

GLOBO 'Y' 800LBS SW/NPT/BW WELDED BONNET

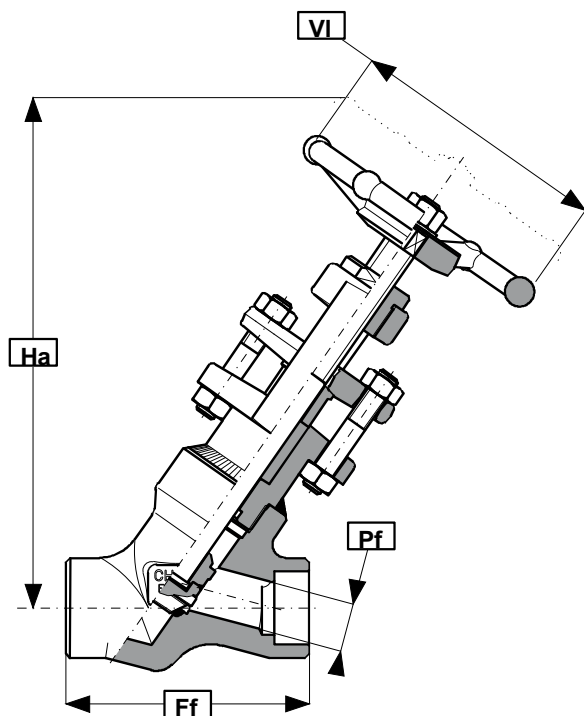

DOUGLAS CHERO Globo 'Y' Fig. Y31xWB		Clase: 800LBS
Válvula Globo 'Y' Acero Carbono 800LBS SW/NPT/BW Welded Bonnet		
Especificaciones		
Material	Acero carbono ASTM A105 ¹	
Presiones	800 p.s.i. a 454°C 1.975 p.s.i. a 38°C	
Pruebas	Hidráulica (mínima): Cuerpo 3.000 p.s.i. Asiento 2.175 p.s.i. Aire bajo el agua: Asiento 85 p.s.i.	
Normas	Construcción ISO 15761 Socket Welding ASME B16.11 Rosca ASME B1.20.1 Butt Welding ASME B16.25	
¹ Ver lista de materiales de construcción		

FIG. Y31xWB - GLOBO 'Y' A105/F6 TRIM N° 1 - 800LBS SW WELDED BONNET

Código	DN	Ff (mm)	Ha (mm)	VI (mm)	Pf (mm)	Peso (kg)
-	1/4"	80	147	90	8	2.4
-	3/8"	80	147	90	9	2.4
-	1/2"	80	147	90	12	2.4
-	3/4"	100	186	100	18	3.0
-	1"	110	220	120	22.5	4.0
-	1.1/4"	120	235	140	29.5	8.0
-	1.1/2"	160	305	140	35	10.0
-	2"	190	352	200	45.5	16.0

» Diseño Paso Total y ejecuciones especiales, bajo demanda

VÁLVULAS FORJADAS ANSI

GLOBO 'Y' 1500LBS SW/NPT/BW WELDED BONNET

DOUGLAS CHERO Globo 'Y' Fig. Y75xWB		Clase: 1500LBS
Válvula Globo 'Y' Acero Carbono 800LBS SW/NPT/BW Welded Bonnet		
Especificaciones		
Material	Acero carbono ASTM A105 ¹	
Presiones	1.500 p.s.i. a 454°C 3.705 p.s.i. a 38°C	
Pruebas	Hidráulica (mínima): Cuerpo 5.575 p.s.i. Asiento 4.100 p.s.i. Aire bajo el agua: Asiento 85 p.s.i.	
Normas	Construcción ISO 15761 - ASME B16.34 Socket Welding ASME B16.11 Rosca ASME B1.20.1 Butt Welding ASME B16.25	
¹ Ver lista de materiales de construcción		

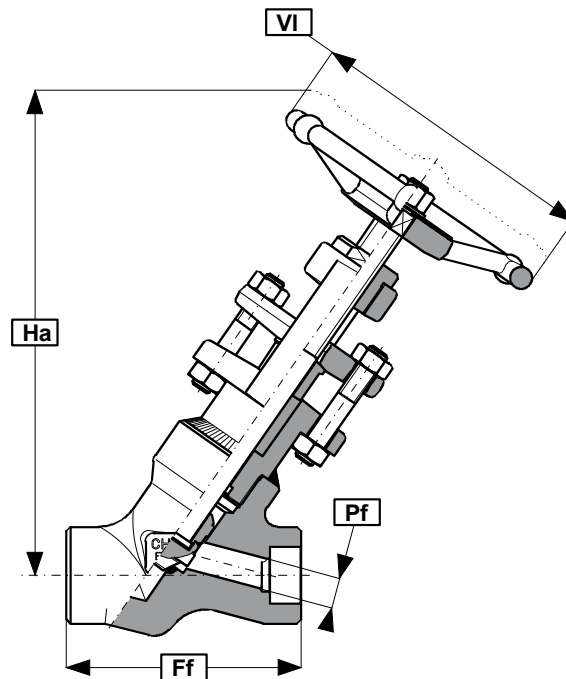
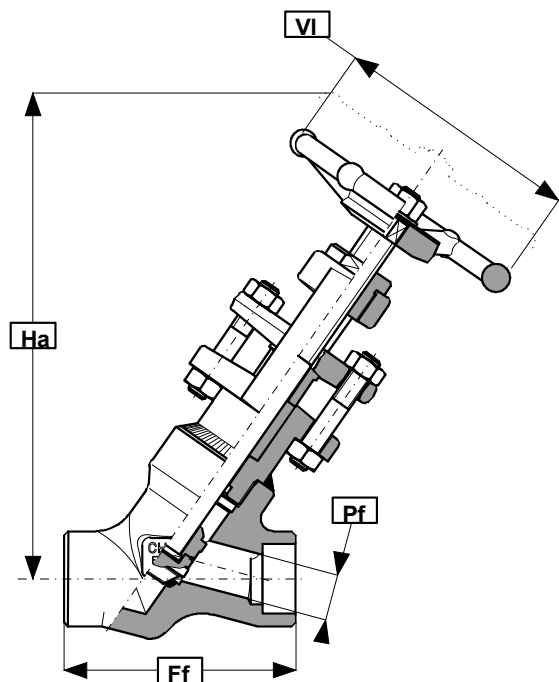

FIG. Y75xWB - GLOBO 'Y' A105/F6 TRIM N°1 - 1500LBS SW WELDED BONNET

Código	DN	Ff (mm)	Ha (mm)	VI (mm)	Pf (mm)	Peso (kg)
-	1/2"	100	186	120	12	3.0
-	3/4"	110	220	175	16	4.0
-	1"	120	229	175	20	7.0
-	1.1/4"	160	305	200	28	10.5
-	1.1/2"	190	348	200	32	15.0
-	2"	190	389	260	43	19.0

» Diseño Paso Total y ejecuciones especiales, bajo demanda

GLOBO 'Y' 2500LBS SW/NPT/BW WELDED BONNET



DOUGLAS CHERO Globo 'Y' Fig. Y115xWB		Clase: 2500LBS
Válvula Globo 'Y' Acero Carbono 2500LBS SW/NPT/BW Welded Bonnet		
Especificaciones		
Material	Acero carbono ASTM A105 ¹	
Presiones	2.500 p.s.i. a 454°C 6.170 p.s.i. a 38°C	
Pruebas	Hidráulica (mínima): Cuerpo 9.275 p.s.i. Asiento 6.800 p.s.i. Aire bajo el agua: Asiento 85 p.s.i.	
Normas	Construcción ASME B16.34 Socket Welding ASME B16.11 Rosca ASME B1.20.1 Butt Welding ASME B16.25	
¹ Ver lista de materiales de construcción		

FIG. Y115xWB - GLOBO 'Y' A105/F6 TRIM N° 1 - 2500LBS SW W.B.

Código	DN	Ff (mm)	Ha (mm)	V1 (mm)	Pf (mm)	Peso (kg)
-	1/2"	110	217	140	10	4.0
-	3/4"	120	276	200	13	5.0
-	1"	120	276	200	18	11.0
-	1.1/4"	190	388	260	24	11.0
-	1.1/2"	190	388	260	28	17.0
-	2"	210	402	350	35	23.0

» Diseño Paso Total y ejecuciones especiales, bajo demanda

VÁLVULAS FORJADAS ANSI

RETENCIÓN 800LBS SW/NPT/BW BOLTED COVER

DOUGLAS CHERO Retención Fig. Rtt5x		Clase: 800LBS
Válvula Retención Acero Carbono 800LBS SW/NPT/BW		
Especificaciones		
Material	Acero carbono ASTM A105 ¹	
Presiones	800 p.s.i. a 454°C 1.975 p.s.i. a 38°C	
Pruebas	Hidráulica (mínima): Cuerpo 3.000 p.s.i. Asiento 2.175 p.s.i.	
Normas	Construcción ISO 15761 Socket Welding ASME B16.11 Rosca ASME B1.20.1 Butt Welding ASME B16.25	
¹ Ver lista de materiales de construcción		

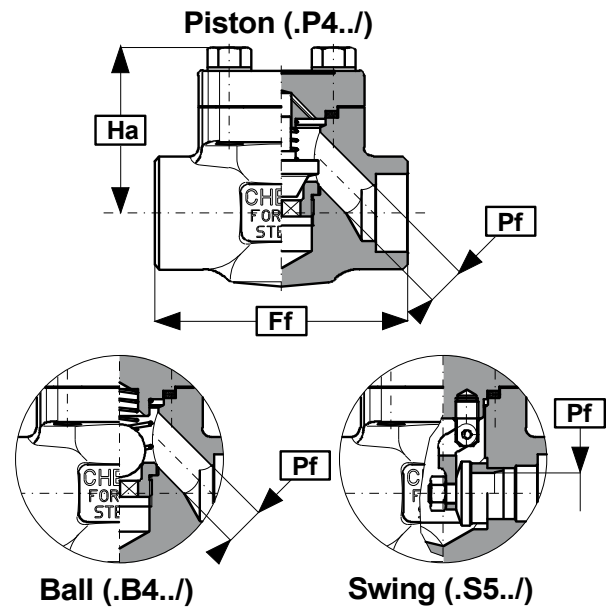

FIG. Rtt5x - RETENCIÓN A PISTÓN A105/F6 TRIM Nº 1 - 800LBS SW BOLTED COVER

Código	DN	Ff (mm)	Ha (mm)	Pf ¹ (mm)	Peso (kg)
010102304040486	1/2"	80	50	9.0	1.1
010102304040487	3/4"	90	56	12.5	1.8
010102304040488	1"	110	74	17.5	2.6
-	1.1/4"	127	79	22.5	3.6
010102304040490	1.1/2"	155	100	28 ¹	5.5
010102304040491	2"	170	109	32 ²	8.4

FIG. Rtt5x - RETENCIÓN A PISTÓN A105/F6 U TRIM Nº 5 - 800LBS SW BOLTED COVER

Código	DN	Ff (mm)	Ha (mm)	Pf ¹ (mm)	Peso (kg)
01010230404042941	1/2"	80	50	9.0	1.1
010102304040493	3/4"	90	56	12.5	1.8
010102304040494	1"	110	74	17.5	2.6
-	1.1/4"	127	79	22.5	3.6
010102304040492	1.1/2"	155	100	28 ¹	5.5
01010230404042942	2"	170	109	32 ²	8.4

FIG. Rtt5x - RETENCIÓN A PISTÓN A105/F6 TRIM Nº 1 - 800LBS NPT BOLTED COVER

Código	DN	Ff (mm)	Ha (mm)	Pf ¹ (mm)	Peso (kg)
010102304040504	1/2"	80	50	9.0	1.1
010102304040506	3/4"	90	56	12.5	1.8
010102304040483	1"	110	74	17.5	2.6
010102304040511	1.1/4"	127	79	22.5	3.6
010102304040510	1.1/2"	155	100	28 ¹	5.5
010102304040509	2"	170	109	32 ²	8.4

» Diseño Paso Total y ejecuciones especiales, bajo demanda

¹ Pf = 29.5 con asientos estrellados integrales

² Pf = 35.0 con asientos estrellados integrales

³ Pf = Dimensiones para Retención a Pistón y Bola

RETENCIÓN 800LBS SW/NPT/BW WELDED COVER

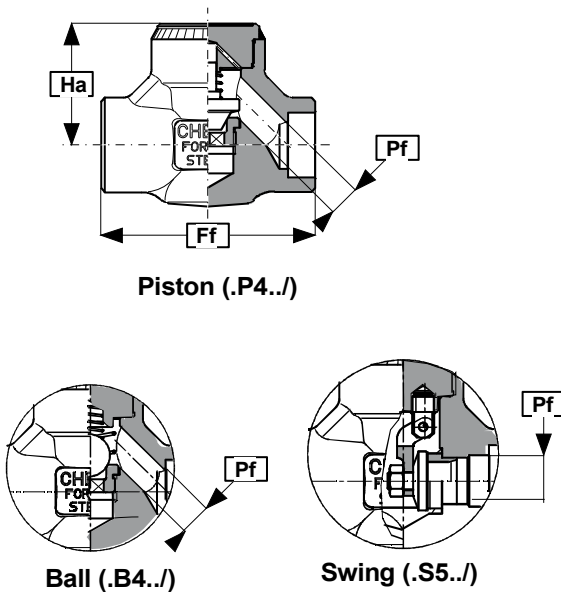

DOUGLAS CHERO Retención Fig. Rtt45xWC		Clase: 800LBS
Válvula Retención Acero Carbono 800LBS SW/NPT/BW Welded Cover		
Especificaciones		
Material	Acero carbono ASTM A105 ¹	
Presiones	800 p.s.i. a 454°C 1.975 p.s.i. a 38°C	
Pruebas	Hidráulica (mínima): Cuerpo 3.000 p.s.i. Asiento 2.175 p.s.i.	
Normas	Construcción ISO 15761 Socket Welding ASME B16.11 Rosca ASME B1.20.1 Butt Welding ASME B16.25	
¹ Ver lista de materiales de construcción		

FIG. Rtt45xWC - RETENCIÓN A PISTÓN A105/F6 TRIM Nº 1 - 800LBS SW WELDED COVER

Código	DN	Ff (mm)	Ha (mm)	Pf (mm)	Peso (kg)
-	1/2"	80	48	9.0	0.8
-	3/4"	90	51	12.5	1.1
-	1"	110	63	17.5	2.0
-	1.1/4"	127	71	22.5	3.3
-	1.1/2"	155	86	28 ¹	4.9
-	2"	170	99	32 ²	7.3

» Diseño Paso Total y ejecuciones especiales, bajo demanda

¹ Pf = 29.5 con asientos estrellados integrales

² Pf = 35.0 con asientos estrellados integrales

VÁLVULAS FORJADAS ANSI

RETENCIÓN 150LBS RF BOLTED COVER

DOUGLAS CHERO Retención Fig. Rtt5x/15		Clase: 150LBS
Válvula Retención Acero Carbono 150LBS RF		
Especificaciones		
Material	Acero carbono ASTM A105 ¹	
Presiones	150 p.s.i. a 288°C 285 p.s.i. a 38°C	
Pruebas	Hidráulica (mínima): Cuerpo 450 p.s.i. Asiento 325 p.s.i.	
Normas	Construcción ISO 15761 Bridas ASME B16.5, ASME B16.10	
¹ Ver lista de materiales de construcción		

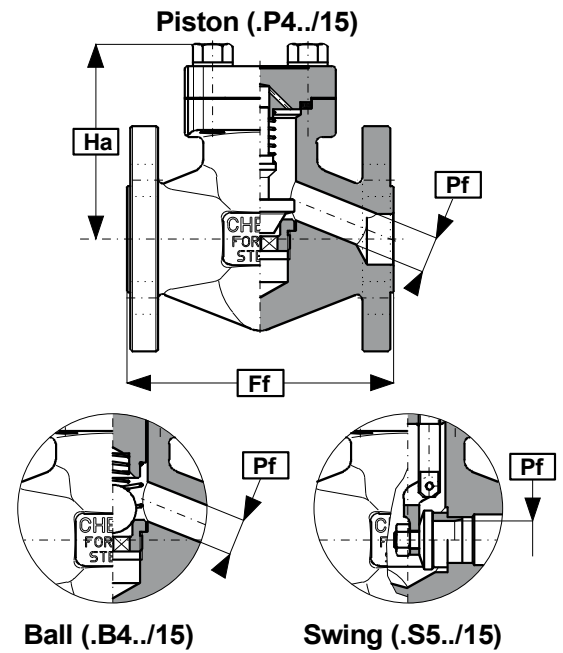

FIG. Rtt5x/15 - RETENCIÓN A PISTÓN A105/F6 TRIM N° 1 - 150LBS RF BOLTED COVER

Código	DN	Ff (mm)	Ha (mm)	PP ³ (mm)	Peso (kg)
-	1/2"	107.9	84	9.0	2.6
-	3/4"	117.5	87	12.5	3.8
010102304042282	1"	127.0	92	17.5	5.1
-	1.1/4"				
-	1.1/2"	165.1	97	28 ¹	8.4
-	2"	203.2	124	32 ²	14.2

» Diseño Paso Total y ejecuciones especiales, bajo demanda

- ¹ Pf = 29.5 con asientos estrellados integrales
- ² Pf = 35.0 con asientos estrellados integrales
- ³ Pf = Dimensiones para Retención a Pistón y Bola

RETENCIÓN 300LBS RF BOLTED COVER

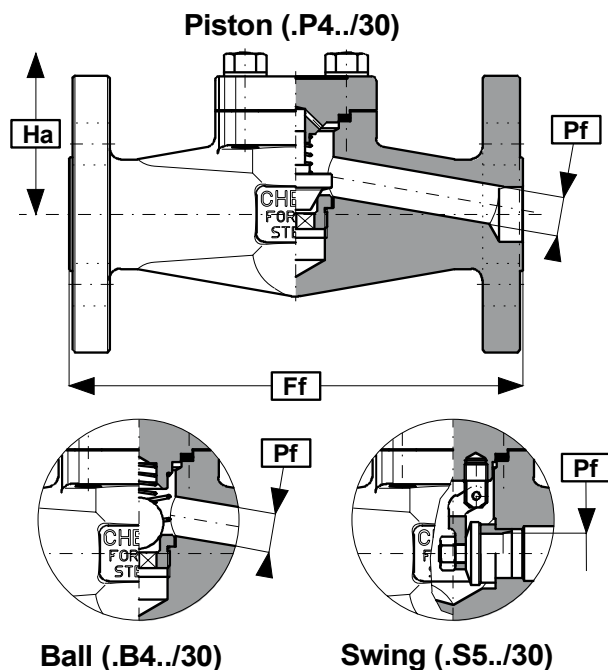

DOUGLAS CHERO Retención Fig. Rtt5x/30		Clase: 300LBS
Válvula Retención Acero Carbono 300LBS RF		
Especificaciones		
Material	Acero carbono ASTM A105 ¹	
Presiones	300 p.s.i. a 454°C 740 p.s.i. a 38°C	
Pruebas	Hidráulica (mínima): Cuerpo 1.125 p.s.i. Asiento 825 p.s.i.	
Normas	Construcción ISO 15761 Bridas ASME B16.5, ASME B16.10	
¹ Ver lista de materiales de construcción		

FIG. Rtt5x/30 - RETENCIÓN A PISTÓN A105/F6 TRIM N° 1 - 300LBS RF BOLTED COVER

Código	DN	Ff (mm)	Ha (mm)	Pf ¹ (mm)	Peso (kg)
-	1/2"	152.4	50	9.0	2.5
-	3/4"	177.8	56	12.5	4.2
-	1"	203.2 ²	74	17.5	5.7
-	1.1/4"				
-	1.1/2"	228.6 ²	100	28 ³	11.2
-	2"	266.7	109	32 ⁴	14.4

» Diseño Paso Total y ejecuciones especiales, bajo demanda

¹ Pf = Dimensiones para Retención a Pistón y Bola

² Para RETENCIÓN a clapeta 1" es 215.9 mm y para 1.1/2" es 241.3 mm

³ Pf = 29.5 con asientos estrellados integrales

⁴ Pf = 35.0 con asientos estrellados integrales

VÁLVULAS FORJADAS ANSI

RETENCIÓN 600LBS RF BOLTED COVER

DOUGLAS CHERO Retención Fig. Rtt5x/60		Clase: 600LBS
Válvula Retención Acero Carbono 600LBS RF		
Especificaciones		
Material	Acero carbono ASTM A105 ¹	
Presiones	600 p.s.i. a 454°C 1.480 p.s.i. a 38°C	
Pruebas	Hidráulica (mínima): Cuerpo 2.225 p.s.i. Asiento 1.650 p.s.i.	
Normas	Construcción ISO 15761 Bridas ASME B16.5, ASME B16.10	
¹ Ver lista de materiales de construcción		

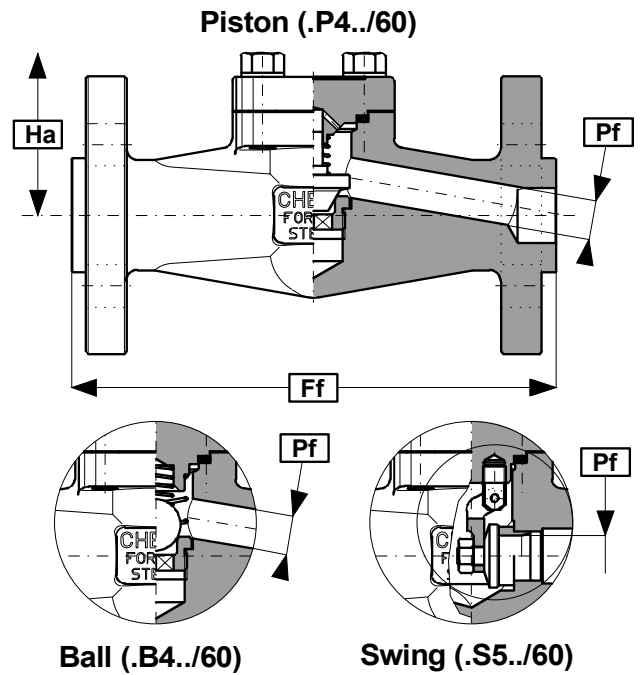

FIG. Rtt5x/60 - RETENCIÓN A PISTÓN A105/F6 TRIM N° 1 - 600LBS RF BOLTED COVER

Código	DN	Ff (mm)	Ha (mm)	Pf ¹ (mm)	Peso (kg)
-	1/2"	165.1	50	9.0	3.1
-	3/4"	190.5	56	12.5	5.0
-	1"	215.9	74	17.5	7.3
-	1.1/4"				
-	1.1/2"	241.3	100	28 ²	12
-	2"	292.1	109	32 ³	16.6

» Diseño Paso Total y ejecuciones especiales, bajo demanda

¹ Pf = Dimensiones para Retención a Pistón y Bola

² Pf = 29.5 con asientos estrellados integrales

³ Pf = 35.0 con asientos estrellados integrales

RETENCIÓN 1500LBS SW/NPT/BW BOLTED COVER

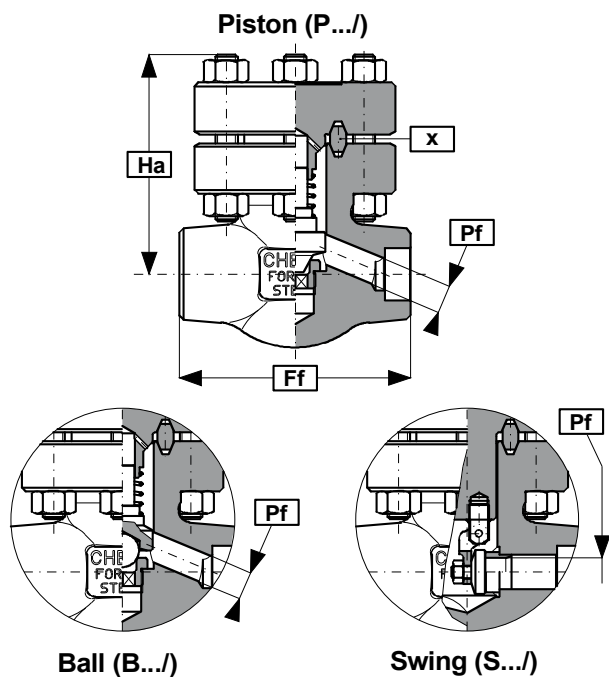

DOUGLAS CHERO Retención Fig. t85x		Clase: 1500LBS
Válvula Retención Acero Carbono 1500LBS SW/NPT/BW		
Especificaciones		
Material	Acero carbono ASTM A105 ¹	
Presiones	1.500 p.s.i. a 288°C 3.705 p.s.i. a 38°C	
Pruebas	Hidráulica (mínima): Cuerpo 5.575 p.s.i. Asiento 4.100 p.s.i.	
Normas	Construcción ISO 15761 Socket Welding ASME B16.11 Rosca ASME B1.20.1 Butt Welding ASME B16.25	
¹ Ver lista de materiales de construcción		

FIG. t85x - RETENCIÓN A PISTÓN A105/F6 TRIM N° 1 - 1500LBS SW BOLTED COVER

Código	DN	Ff (mm)	Ha (mm)	Pf (mm)	Peso (kg)
-	1/2"	110	93	11	3.8
-	3/4"	115	109	14.5	5.9
-	1"	130	122	19	6.8
-	1.1/4"				
-	1.1/2"	210	158	31	18.8
-	2"	240	171	37.5	23.7

» Diseño Paso Total y ejecuciones especiales, bajo demanda

¹ Pf = Dimensiones para Retención a Pistón y Bola

VÁLVULAS FORJADAS ANSI

RETENCIÓN 1500LBS SW/NPT/BW WELDED COVER

DOUGLAS CHERO Retención Fig. t85xWC		Clase: 1500LBS
Válvula Retención Acero Carbono 1500LBS SW/NPT/BW Welded Cover		
Especificaciones		
Material	Acero carbono ASTM A105 ¹	
Presiones	1.500 p.s.i. a 454°C 3.705 p.s.i. a 38°C	
Pruebas	Hidráulica (mínima): Cuerpo 5.575 p.s.i. Asiento 4.100 p.s.i.	
Normas	Construcción ISO 15761 Socket Welding ASME B16.11 Rosca ASME B1.20.1 Butt Welding ASME B16.25	
¹ Ver lista de materiales de construcción		

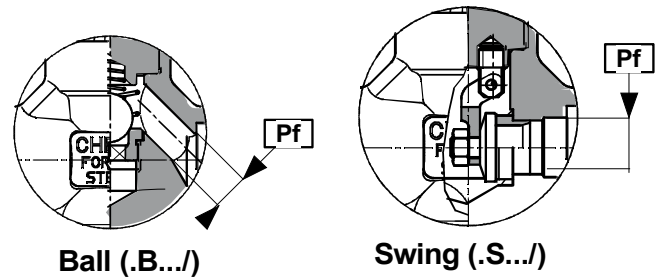
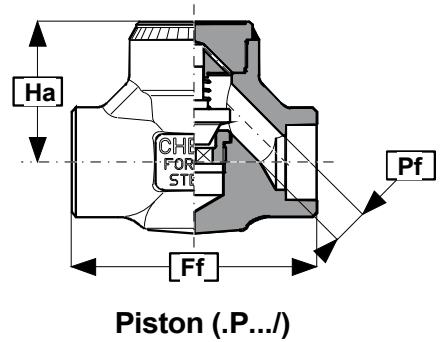

FIG. t85xWC - RETENCIÓN A PISTÓN A105/F6 TRIM N° 1 - 1500LBS SW WELDED COVER

Código	DN	Ff (mm)	Ha (mm)	Pf ¹ (mm)	Peso (kg)
-	1/2"	90	51	11	1.4
-	3/4"	110	57	14.5	2.4
-	1"	127	62	19	3.8
-	1.1/4"				
-	1.1/2"	170	90	31	8.0
-	2"	210	117	37.5	14.5

» Diseño Paso Total y ejecuciones especiales, bajo demanda

¹ Pf = Dimensiones para Retención a Pistón y Bola

RETENCIÓN 1500LBS RF BOLTED COVER

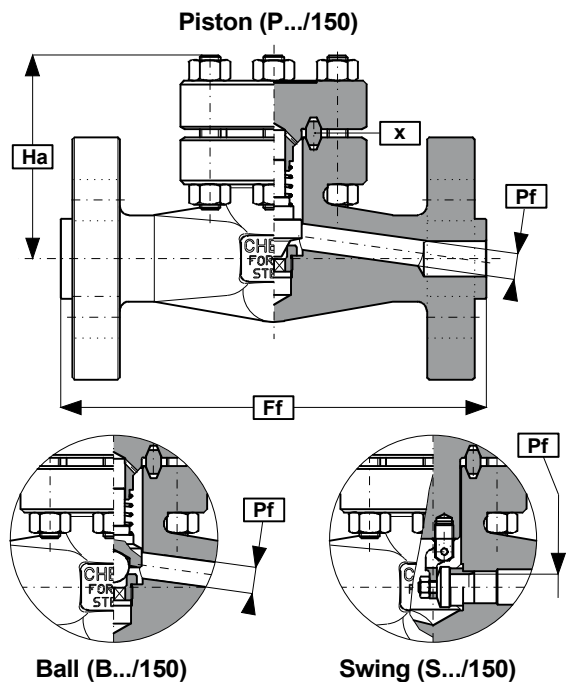

DOUGLAS CHERO Retención Fig. t85x/150		Clase: 1500LBS
Válvula Retención Acero Carbono 1500LBS RF Bolted Cover		
Especificaciones		
Material	Acero carbono ASTM A105 ¹	
Presiones	1.500 p.s.i. a 454°C 3.705 p.s.i. a 38°C	
Pruebas	Hidráulica (mínima): Cuerpo 5.575 p.s.i. Asiento 4.100 p.s.i.	
Normas	Construcción ISO 15761 Bridas ASME B16.5, ASME B16.10	
¹ Ver lista de materiales de construcción		

FIG. t85x/150 - RETENCIÓN A PISTÓN A105/F6 TRIM N° 1 - 1500LBS RF BOLTED COVER

Código	DN	Ff (mm)	Ha (mm)	Pf ¹ (mm)	Peso (kg)
-	1/2"	215.9	93	11	7.5
-	3/4"	228.6	109	14.5	10.9
-	1"	254.0	122	19	14.4
-	1.1/4"				
-	1.1/2"	304.8	158	31	30.3
-	2"	368.3	171	37.5	44.0

» Diseño Paso Total y ejecuciones especiales, bajo demanda

¹ Pf = Dimensiones para Retención a Pistón y Bola

VÁLVULAS FORJADAS ANSI

RETENCIÓN 2500LBS SW/NPT/BW BOLTED COVER

DOUGLAS CHERO Retención Fig. t125x		Clase: 2500LBS
Válvula Retención Acero Carbono 2500LBS SW/NPT/BW Bolted Cover		
Especificaciones		
Material	Acero carbono ASTM A105 ¹	
Presiones	2.500 p.s.i. a 454°C 6.170 p.s.i. a 38°C	
Pruebas	Hidráulica (mínima): Cuerpo 9.275 p.s.i. Asiento 6.800 p.s.i.	
Normas	Construcción ASME B16.34 Socket Welding ASME B16.11 Rosca ASME B1.20.1 Butt Welding ASME B16.25	
¹ Ver lista de materiales de construcción		

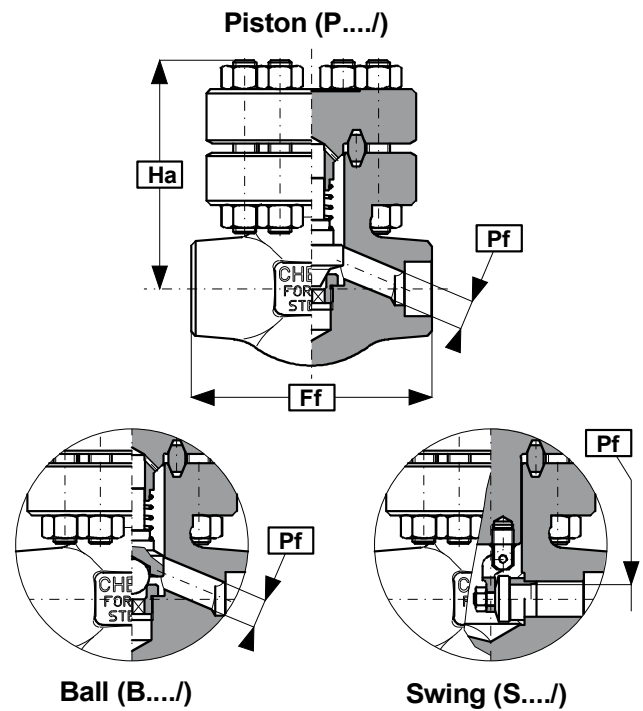

FIG. t125x - RETENCIÓN A PISTÓN A105/F6 TRIM N° 1 - 2500LBS SW BOLTED COVER

Código	DN	Ff (mm)	Ha (mm)	Pf ¹ (mm)	Peso (kg)
-	1/2"	110	93	10	4.0
-	3/4"	115	109	13	6.2
-	1"	130	122	18	7.2
-	1.1/4"				
-	1.1/2"	210	158	25	19.4
-	2"	240	171	34	24.5

» Diseño Paso Total y ejecuciones especiales, bajo demanda

¹ Pf = Dimensiones para Retención a Pistón y Bola

RETENCIÓN 2500LBS SW/NPT/BW WELDED COVER

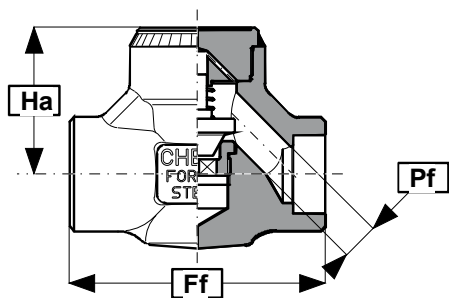

Piston (.P.../)

DOUGLAS CHERO Retención Fig. t125xWC		Clase: 2500LBS
Válvula Retención Acero Carbono 2500LBS SW/NPT/BW Welded Cover		
Especificaciones		
Material	Acero carbono ASTM A105 ¹	
Presiones	2.500 p.s.i. a 454°C 6.170 p.s.i. a 38°C	
Pruebas	Hidráulica (mínima): Cuerpo 9.275 p.s.i. Asiento 6.800 p.s.i.	
Normas	Construcción ASME B16.34 Socket Welding ASME B16.11 Rosca ASME B1.20.1 Butt Welding ASME B16.25	
¹ Ver lista de materiales de construcción		

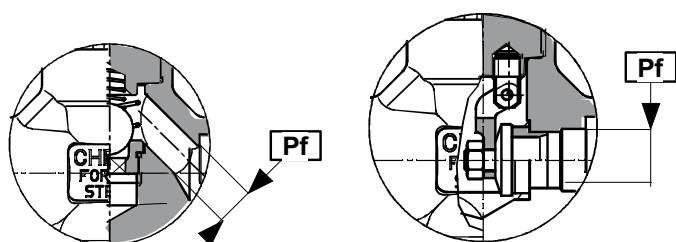

Ball (.B.../)

Swing (.S.../)

FIG. t125xWC - RETENCIÓN A PISTÓN A105/F6 TRIM Nº 1 - 2500LBS SW WELDED COVER

Código	DN	Ff (mm)	Ha (mm)	Pf ¹ (mm)	Peso (kg)
-	1/2"	110	60	10	2.0
-	3/4"	127	71	13	3.2
-	1"	155	85	18	4.8
-	1.1/4"				
-	1.1/2"	210	120	25	9.6
-	2"	240	130	34	16

» Diseño Paso Total y ejecuciones especiales, bajo demanda

¹ Pf = Dimensiones para Retención a Pistón y Bola

VÁLVULAS FORJADAS ANSI

RETENCIÓN 2500LBS RF BOLTED COVER

DOUGLAS CHERO Retención Fig. t125x/250		Clase: 2500LBS
Válvula Retención Acero Carbono 2500LBS RF Bolted Cover		
Especificaciones		
Material	Acero carbono ASTM A105 ¹	
Presiones	2.500 p.s.i. a 454°C 6.170 p.s.i. a 38°C	
Pruebas	Hidráulica (mínima): Cuerpo 9.275 p.s.i. Asiento 6.800 p.s.i.	
Normas	Construcción ASME B16.34 Bridas ASME B16.5, ASME B16.10	
¹ Ver lista de materiales de construcción		

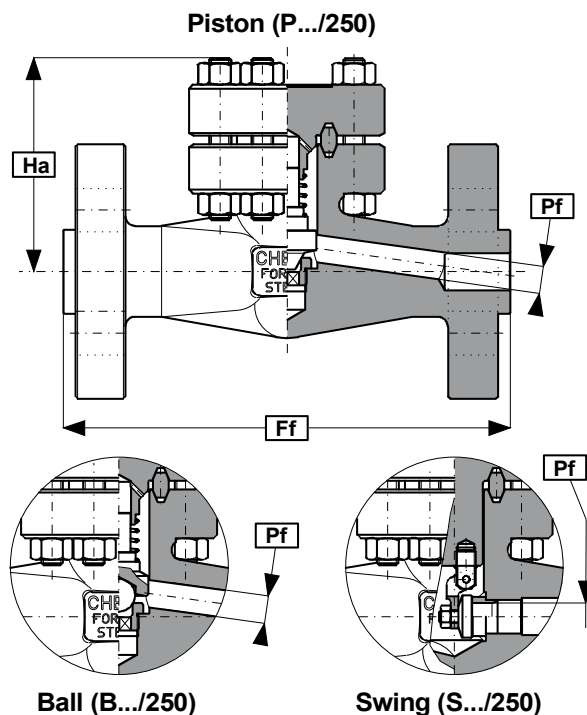

FIG. t125x/250 - RETENCIÓN A PISTÓN A105/F6 TRIM N° 1 - 2500LBS RF BOLTED COVER

Código	DN	Ff (mm)	Ha (mm)	Pf ¹ (mm)	Peso (kg)
-	1/2"	263.5	93	10	8.5
-	3/4"	273.0	109	13	12.5
-	1"	308.0	122	18	19.2
-	1.1/4"				
-	1.1/2"	384.2	158	25	40.8
-	2"	450.8	171	34	59.0

» Diseño Paso Total y ejecuciones especiales, bajo demanda

¹ Pf = Dimensiones para Retención a Pistón y Bola

RETENCIÓN 4500LBS SW/NPT/BW WELDED COVER

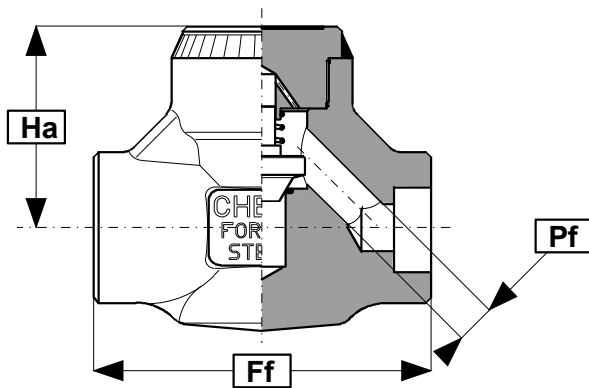

DOUGLAS CHERO Retención Fig. P225xWC		Clase: 4500LBS
Válvula Retención Acero Carbono 4500LBS SW/NPT/BW Welded Cover		
Especificaciones		
Material	Acero carbono ASTM A105 ¹	
Presiones	4.010 p.s.i. a 454°C 11.110 p.s.i. a 38°C	
Pruebas	Hidráulica (mínima): Cuerpo 16.650 p.s.i. Asiento 12.210 p.s.i.	
Normas	Construcción ASME B16.34 Socket Welding ASME B16.11 Rosca ASME B1.20.1 Butt Welding ASME B16.25	
¹ Ver lista de materiales de construcción		

FIG. P225xWC - RETENCIÓN A PISTÓN A105/F6 TRIM N° 1 - 4500LBS SW WELDED COVER

Código	DN	Ff (mm)	Ha (mm)	Pf (mm)	Peso (kg)
-	1/2"	127	75	7	3.2
-	3/4"	155	90	11	4.8
-	1"	170	125	15	8
-	1.1/4"				
-	1.1/2"	240	145	25	16
-	2"	240	140	30	26

» Diseño Paso Total y ejecuciones especiales, bajo demanda

¹ Pf = Dimensiones para Retención a Pistón y Bola

VÁLVULAS FORJADAS ANSI

RETENCIÓN 'Y' 800LBS SW/NPT/BW WELDED COVER

DOUGLAS CHERO Retención 'Y' Fig. YP41xWC		Clase: 800LBS
Válvula Retención 'Y' Acero Carbono 800LBS SW/NPT/BW Welded Cover		
Especificaciones		
Material	Acero carbono ASTM A105 ¹	
Presiones	800 p.s.i. a 454°C 1.975 p.s.i. a 38°C	
Pruebas	Hidráulica (mínima): Cuerpo 3.000 p.s.i. Asiento 2.175 p.s.i.	
Normas	Construcción ISO 15761 Socket Welding ASME B16.11 Rosca ASME B1.20.1 Butt Welding ASME B16.25	
¹ Ver lista de materiales de construcción		

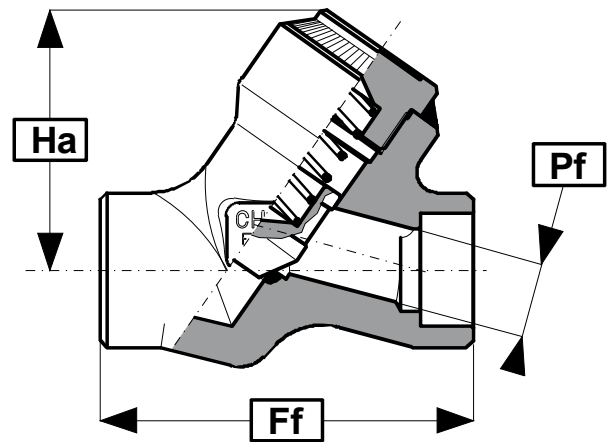
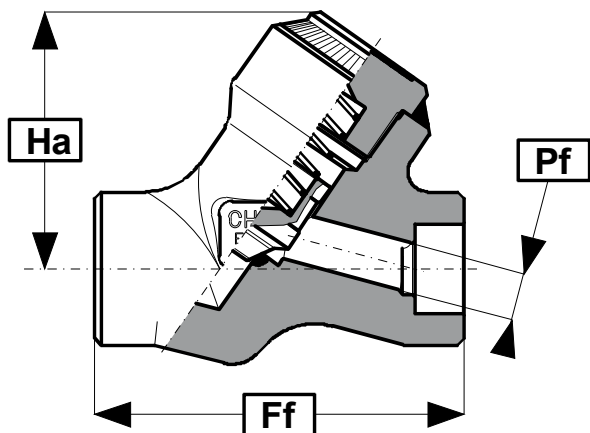

FIG. YP41xWC - RETENCIÓN A PISTÓN 'Y' A105/F6 TRIM N° 1 - 800LBS SW WELDED COVER

Código	DN	Ff (mm)	Ha (mm)	Pf (mm)	Peso (kg)
-	1/4"	80	58	8	1.5
-	3/8"	80	58	9	1.5
-	1/2"	80	58	12.5	1.5
-	3/4"	100	74	18	2.5
-	1"	110	80	22.5	3.0
-	1.1/4"	120	86	29.5	5.5
-	1.1/2"	160	118	35	6.0
-	2"	190	142	45.5	9.0

» Diseño Paso Total y ejecuciones especiales, bajo demanda

RETENCIÓN 'Y' 1500LBS SW/NPT/BW WELDED COVER



DOUGLAS CHERO Retención 'Y' Fig. YP85xWC		Clase: 1500LBS
Válvula Retención 'Y' Acero Carbono 1500LBS SW/NPT/BW Welded Cover		
Especificaciones		
Material	Acero carbono ASTM A105 ¹	
Presiones	1.500 p.s.i. a 454°C 3.705 p.s.i. a 38°C	
Pruebas	Hidráulica (mínima): Cuerpo 5.575 p.s.i. Asiento 4.100 p.s.i.	
Normas	Construcción ISO 15761, ASME B16.34 Socket Welding ASME B16.11 Rosca ASME B1.20.1 Butt Welding ASME B16.25	
¹ Ver lista de materiales de construcción		

FIG. YP85xWC - RETENCIÓN A PISTÓN 'Y' A105/F6 TRIM Nº 1 - 1500LBS SW WELDED COVER

Código	DN	Ff (mm)	Ha (mm)	Pf (mm)	Peso (kg)
-	1/2"	100	80	12	2.5
-	3/4"	110	87	16	3.0
-	1"	120	90	20	4.5
-	1.1/4"	160	121	28	5.5
-	1.1/2"	190	146	32	8.0
-	2"	190	146	43	9.5

» Diseño Paso Total y ejecuciones especiales, bajo demanda

VÁLVULAS FORJADAS ANSI

RETENCIÓN 'Y' 2500LBS SW/NPT/BW WELDED COVER

DOUGLAS CHERO Retención 'Y' Fig. YP125xWC		Clase: 2500LBS
Válvula Retención 'Y' Acero Carbono 2500LBS SW/NPT/BW Welded Cover		
Especificaciones		
Material	Acero carbono ASTM A105 ¹	
Presiones	2.500 p.s.i. a 454°C 6.170 p.s.i. a 38°C	
Pruebas	Hidráulica (mínima): Cuerpo 9.275 p.s.i. Asiento 6.800 p.s.i.	
Normas	Construcción ASME B16.34 Socket Welding ASME B16.11 Rosca ASME B1.20.1 Butt Welding ASME B16.25	
¹ Ver lista de materiales de construcción		

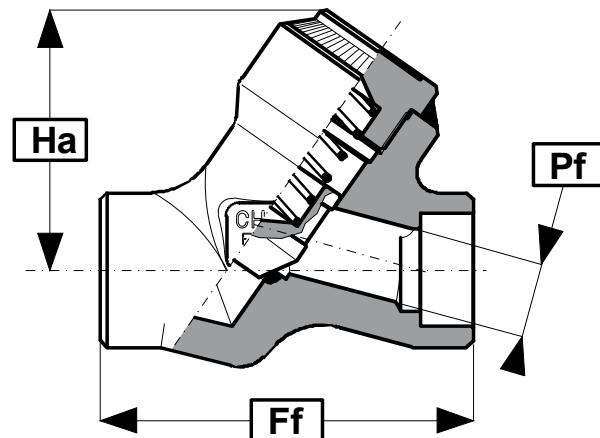
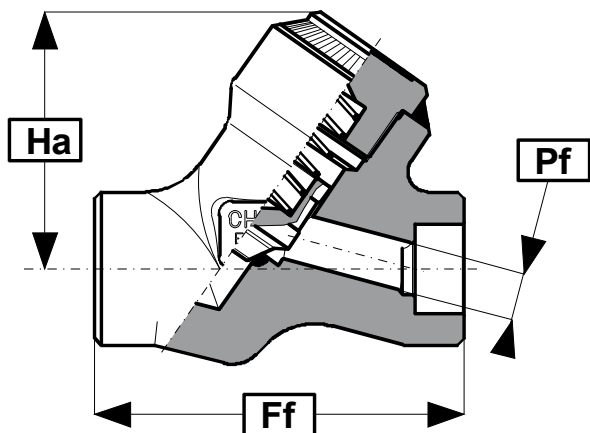

FIG. YP125xWC - RETENCIÓN A PISTÓN 'Y' A105/F6 TRIM N° 1 - 2500LBS SW WELDED COVER

Código	DN	Ff (mm)	Ha (mm)	Pf (mm)	Peso (kg)
-	1/2"	110	87	10	3.2
-	3/4"	120	92	13	4.5
-	1"	120	92	18	4.5
-	1.1/4"	190	146	24	9.5
-	1.1/2"	190	146	28	9.5
-	2"	210	158	35	12.0

» Diseño Paso Total y ejecuciones especiales, bajo demanda

RETENCIÓN 'Y' 4500LBS SW/NPT/BW WELDED COVER



DOUGLAS CHERO Retención 'Y' Fig. YP225xWC		Clase: 4500LBS
Válvula Retención 'Y' Acero Carbono 4500LBS SW/NPT/BW Welded Cover		
Especificaciones		
Material	Acero carbono ASTM A105 ¹	
Presiones	4.010 p.s.i. a 454°C 11.110 p.s.i. a 38°C	
Pruebas	Hidráulica (mínima): Cuerpo 16.650 p.s.i. Asiento 12.210 p.s.i.	
Normas	Construcción ASME B16.34 Socket Welding ASME B16.11 Rosca ASME B1.20.1 Butt Welding ASME B16.25	
¹ Ver lista de materiales de construcción		

FIG. YP225xWC - RETENCIÓN A PISTÓN 'Y' A105/F6 TRIM N° 1 - 4500LBS SW WELDED COVER

Código	DN	Ff (mm)	Ha (mm)	Pf (mm)	Peso (kg)
-	1/2"	120	90	7	4.5
-	3/4"	160	120	11	7.5
-	1"	190	145	14	9.5
-	1.1/4"				
-	1.1/2"	210	160	25	12.0
-	2"	230	200	30	23.0

» Diseño Paso Total y ejecuciones especiales, bajo demanda

VÁLVULAS FORJADAS PRESSURE SEAL

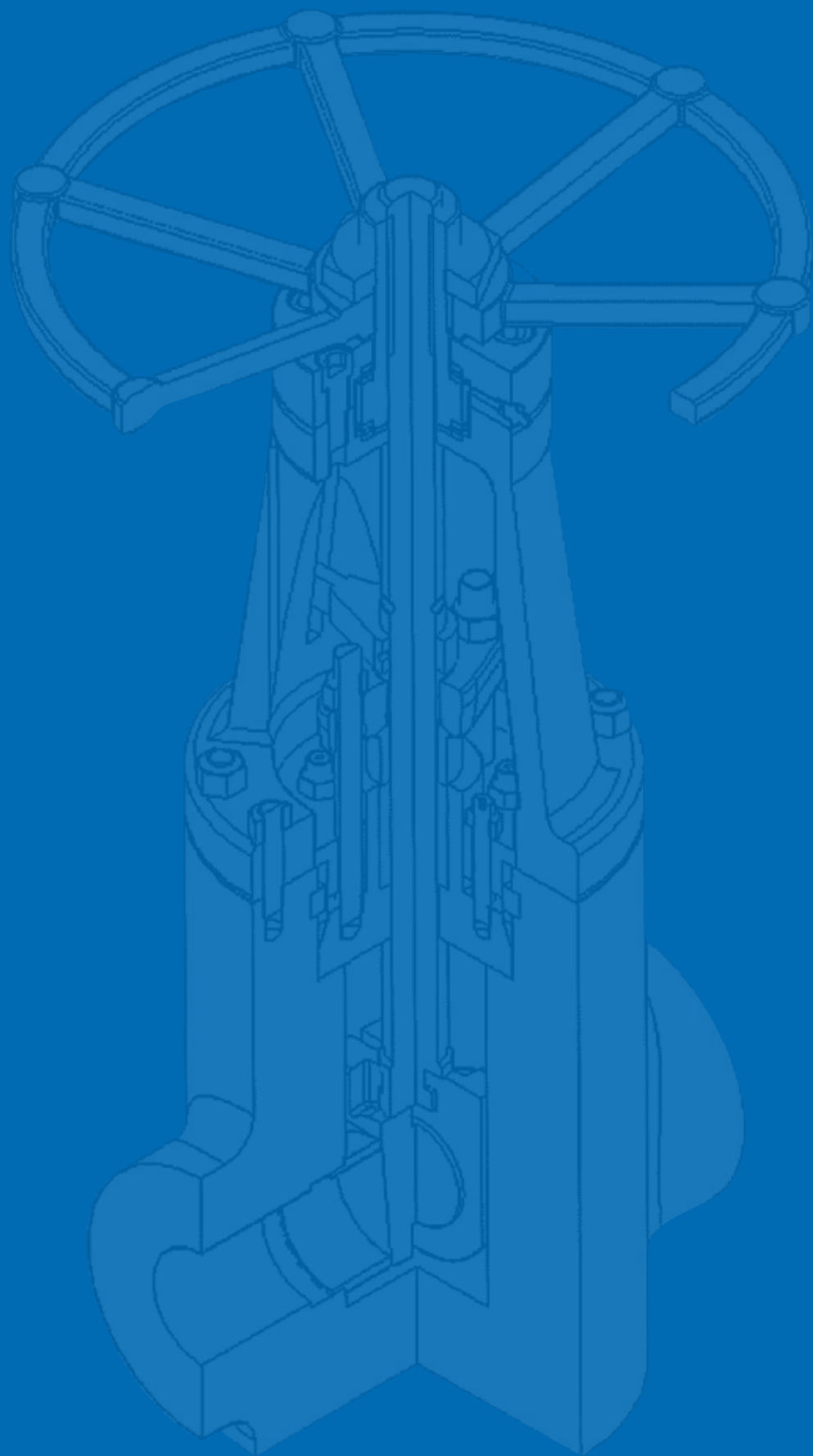

VÁLVULAS PARA ALTAS PRESIONES



VÁLVULAS FORJADAS PRESSURE SEAL

COMPUERTA 1500LBS SW/BW PRESSURE SEAL

DOUGLAS CHERO COMPUERTA Fig. 65xPS		Clase: 1500LBS
Válvula Compuerta Acero Carbono 1500LBS SW/BW		
Especificaciones		
Material	Acero carbono ASTM A105 ¹	
Presiones	1.500 p.s.i. a 454°C 3.705 p.s.i. a 38°C	
Pruebas	Hidráulica (mínima): Cuerpo 5.575 p.s.i. Asiento 4.100 p.s.i. Aire bajo el agua: Asiento 85 p.s.i.	
Diseño	ASME B16.34	
Normas	Basada en ASME B16.34 Socket Welding ASME B16.11 Butt Welding ASME B16.25	
¹ Ver lista de materiales de construcción		

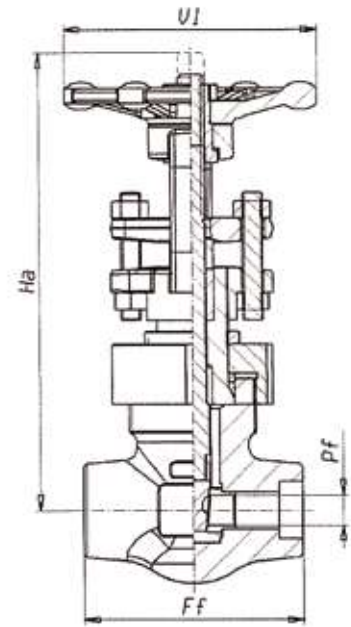

FIG. 65xPS - COMPUERTA A105/F6 TRIM N° 1 - 1500LBS SW PRESSURE SEAL

Código	DN	Ff (mm)	Ha (mm)	U1 (mm)	Pf (mm)	Peso (kg)
-	1/2"	110	219	120	11,5	5,9
-	3/4"	115	263	175	15,0	8,4
-	1"	130	278	175	19,5	9,8
-	1.1/4"					
-	1.1/2"	210	400	225	32	26,8
-	2"	240	414	250	40	35,0

FIG. 65xPS - COMPUERTA A105/F6 U TRIM N° 5 - 1500LBS SW PRESSURE SEAL

Código	DN	Ff (mm)	Ha (mm)	U1 (mm)	Pf (mm)	Peso (kg)
-	1/2"	110	219	120	11,5	5,9
-	3/4"	115	263	175	15,0	8,4
-	1"	130	278	175	19,5	9,8
-	1.1/4"					
-	1.1/2"	210	400	225	32	26,8
-	2"	240	414	250	40	35,0

COMPUERTA 2500LBS SW/BW PRESSURE SEAL

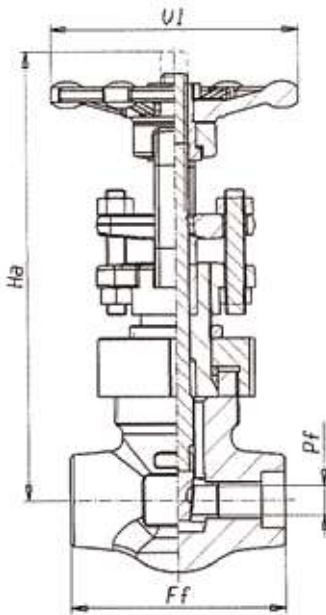

DOUGLAS CHERO COMPUERTA Fig. 105xPS		Clase: 2500LBS
Válvula Compuerta Acero Carbono 2500LBS SW/BW		
Especificaciones		
Material	Acero carbono ASTM A105 ¹	
Presiones	2.500 p.s.i. a 454°C 6.170 p.s.i. a 38°C	
Pruebas	Hidráulica (mínima): Cuerpo 9.275 p.s.i. Asiento 6.800 p.s.i. Aire bajo el agua: Asiento 85 p.s.i.	
Diseño	ASME B16.34	
Normas	Construcción basada en ASME B16.34 Socket Welding ASME B16.11 Butt Welding ASME B16.25	
¹ Ver lista de materiales de construcción		

FIG. 105xPS - COMPUERTA A105/F6 TRIM N° 1 - 2500LBS SW PRESSURE SEAL

Código	DN	Ff (mm)	Ha (mm)	VI (mm)	Pf (mm)	Peso (kg)
-	1/2"	110	233	140	10,0	6,1
-	3/4"	115	272	175	14,0	8,7
-	1"	130	287	175	18,0	10,2
-	1.1/4"					
-	1.1/2"	210	398	250	31,0	27,4
-	2"	240	438	350	36,5	36,0

VÁLVULAS FORJADAS PRESSURE SEAL

COMPUERTA 900LBS SW/BW PRESSURE SEAL

DOUGLAS CHERO COMPUERTA Fig. 60xPS		Clase: 900LBS
Válvula Compuerta Acero Carbono 900LBS SW/BW		
Especificaciones		
Material	Acero carbono ASTM A105 ¹	
Presiones	900 p.s.i. a 454°C 2.220 p.s.i. a 38°C	
Pruebas	Hidráulica (mínima): Cuerpo 3.330 p.s.i. Asiento 2.442 p.s.i. Aire bajo el agua: Asiento 85 p.s.i.	
Diseño	API 598, BS EN 12266 (Parte 1)	
Normas	Construcción basada en API 600 Socket Welding ASME B16.11 Butt Welding ASME B16.25	
¹ Ver lista de materiales de construcción		

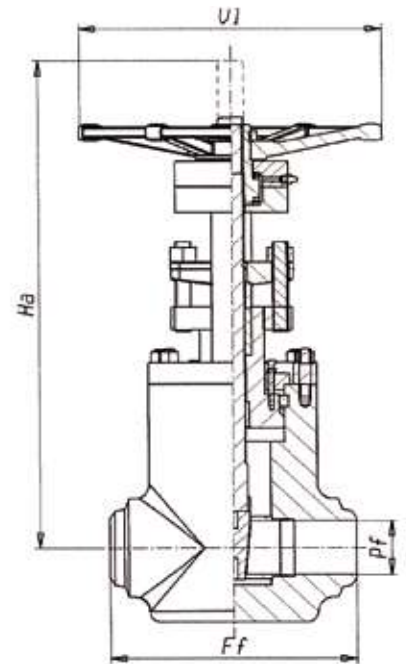

FIG. 60xPS - COMPUERTA A105/F6 TRIM N° 1 - 900LBS SW PRESSURE SEAL

Código	DN	Ff (mm)	Ha (mm)	VI (mm)	Pf (mm)	Peso (kg)
-	3"	305	600	350	72	85
-	4"	356	660	350	98	160
-	6"	508	1000	Con Reductor	146	410
-	8"	660	1300	Con Reductor	190	737
-	10"	787	1495	Con Reductor	210	245
-	12"	864	1690	Con Reductor	245	1545

FIG. 60xPS - COMPUERTA A105/F6 U TRIM N° 5 - 900LBS SW PRESSURE SEAL

Código	DN	Ff (mm)	Ha (mm)	VI (mm)	Pf (mm)	Peso (kg)
-	3"	305	600	350	72	85
-	4"	356	660	350	98	160
-	6"	508	1000	Con Reductor	146	410
-	8"	660	1300	Con Reductor	190	737
-	10"	787	1495	Con Reductor	210	245
-	12"	864	1690	Con Reductor	245	1545

COMPUERTA 1500LBS SW/BW PRESSURE SEAL

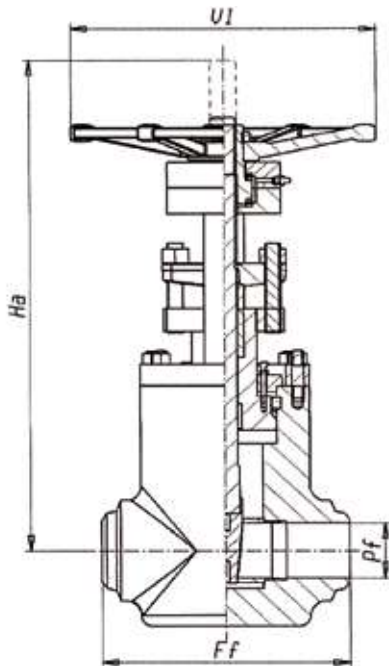

DOUGLAS CHERO COMPUERTA Fig. 65xPS		Clase: 1500LBS
Válvula Compuerta Acero Carbono 1500LBS SW/BW		
Especificaciones		
Material	Acero carbono ASTM A105 ¹	
Presiones	1.500 p.s.i. a 454°C 3.705 p.s.i. a 38°C	
Pruebas	Hidráulica (mínima): Cuerpo 5.557 p.s.i. Asiento 4.075 p.s.i. Aire bajo el agua: Asiento 85 p.s.i.	
Diseño	API 598, BS EN 12266 (Parte 1)	
Normas	Construcción basada en API 600 Socket Welding ASME B16.11 Butt Welding ASME B16.25	
¹ Ver lista de materiales de construcción		

FIG. 65xPS - COMPUERTA A105/F6 TRIM N° 1 - 1500LBS SW PRESSURE SEAL

Código	DN	Ff (mm)	Ha (mm)	Vi (mm)	Pf (mm)	Peso (kg)
-	3"	305	630	350	69	90
-	4"	406	690	350	98	170
-	6"	559	1100	Con Reductor	137	430
-	8"	711	1350	Con Reductor	178	750
-	10"	864	1495	Con Reductor	210	1015
-	12"	864	1690	Con Reductor	245	1545

VÁLVULAS FORJADAS PRESSURE SEAL

COMPUERTA 2500LBS SW/BW PRESSURE SEAL

DOUGLAS CHERO COMPUERTA Fig. 105xPS		Clase: 2500LBS
Válvula Compuerta Acero Carbono 2500LBS SW/BW		
Especificaciones		
Material	Acero carbono ASTM A105 ¹	
Presiones	2.500 p.s.i. a 454°C 6.170 p.s.i. a 38°C	
Pruebas	Hidráulica (mínima): Cuerpo 9.255 p.s.i. Asiento 6.787 p.s.i. Aire bajo el agua: Asiento 85 p.s.i.	
Diseño	API 598, BS EN 12266 (Parte 1)	
Normas	Construcción basada en API 600 Socket Welding ASME B16.11 Butt Welding ASME B16.25	
¹ Ver lista de materiales de construcción		

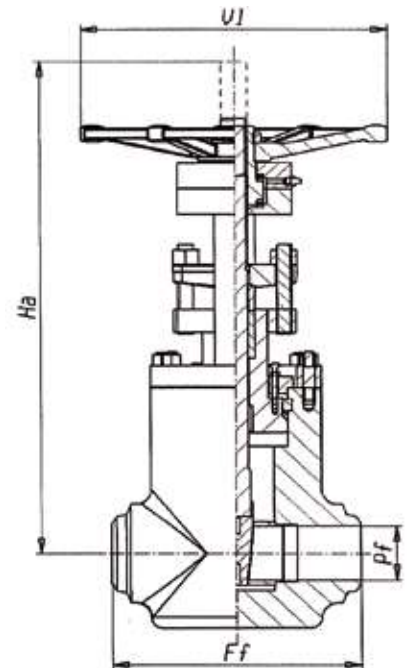
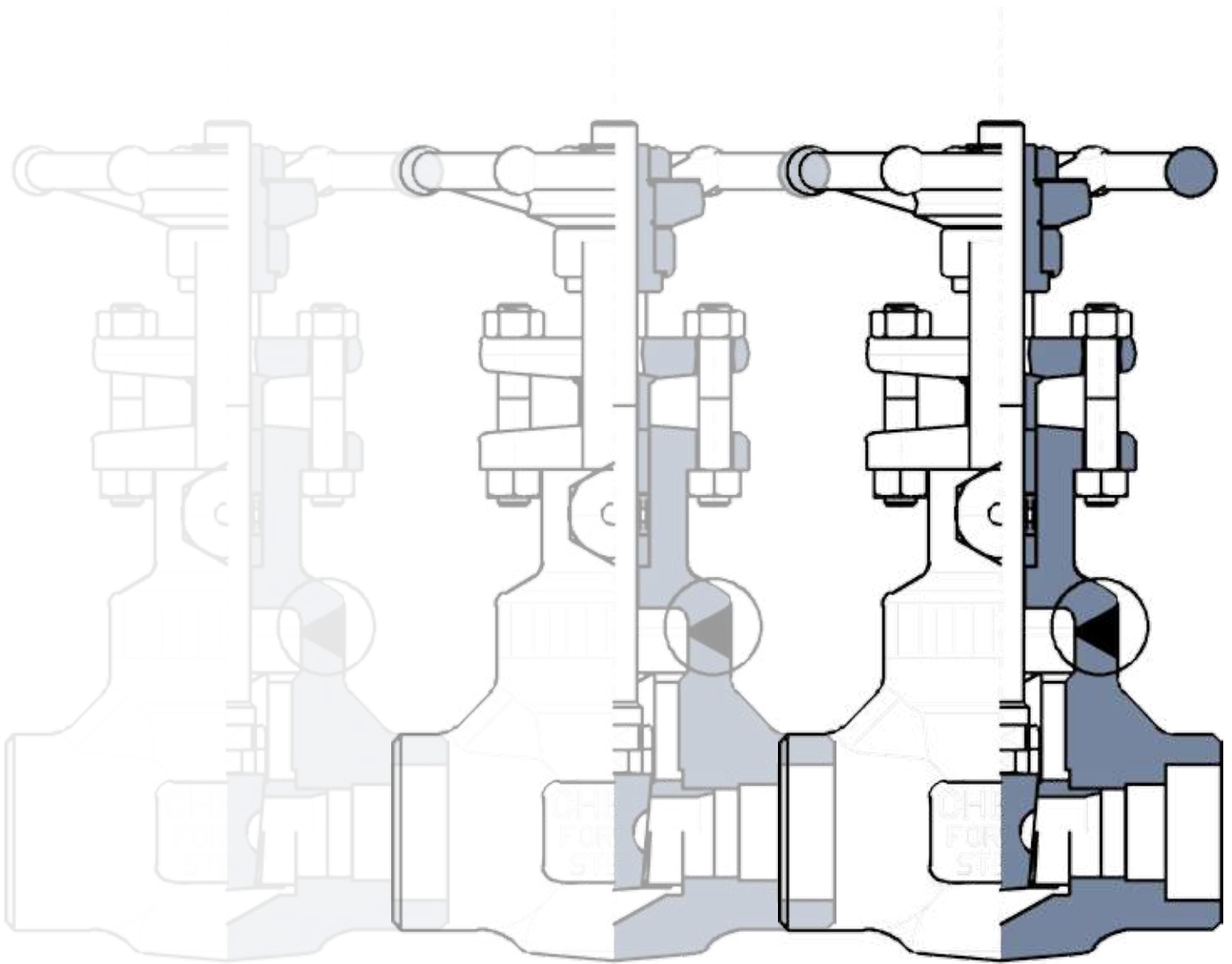

FIG. 105xPS - COMPUERTA A105/F6 TRIM N° 1 - 2500LBS SW PRESSURE SEAL

Código	DN	Ff (mm)	Ha (mm)	VI (mm)	Pf (mm)	Peso (kg)
-	3"	368	600	350	57	95
-	4"	457	660	Con Reductor	73	170
-	6"	610	1000	Con Reductor	111	430
-	8"	762	1300	Con Reductor	146	790
-	10"	864	1400	Con Reductor	184	1400
-	12"	864	1770	Con Reductor	218	1850



GLOBEVALVES

VÁLVULAS FORJADAS PRESSURE SEAL

GLOBO 1500LBS SW/BW PRESSURE SEAL

DOUGLAS CHERO GLOBO Fig. 75xPS		Clase: 1500LBS
Válvula Globo Acero Carbono 1500LBS SW/BW		
Especificaciones		
Material	Acero carbono ASTM A105 ¹	
Presiones	1.500 p.s.i. a 454°C 3.705 p.s.i. a 38°C	
Pruebas	Hidráulica (mínima): Cuerpo 5.575 p.s.i. Asiento 4.100 p.s.i. Aire bajo el agua: Asiento 85 p.s.i.	
Diseño	ASME B16.34	
Normas	Construcción basada en ASME B16.34 Socket Welding ASME B16.11 Butt Welding ASME B16.25	
¹ Ver lista de materiales de construcción		

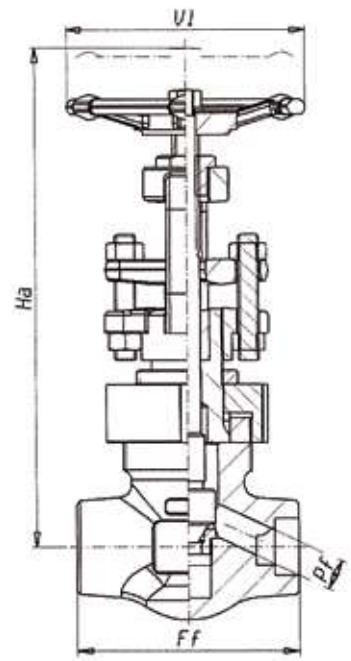
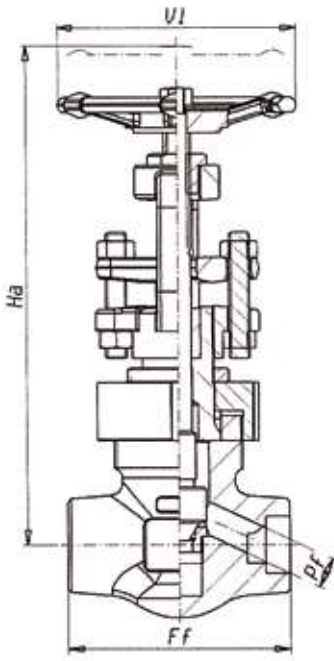

FIG. 75xPS - GLOBO A105/F6 TRIM N° 1 - 1500LBS SW PRESSURE SEAL

Código	DN	Ff (mm)	Ha (mm)	VI (mm)	Pf (mm)	Peso (kg)
-	1/2"	110	223	120	11,0	4,7
-	3/4"	115	270	140	14	7,4
-	1"	130	286	140	18,0	8,4
-	1.1/4"					
-	1.1/2"	210	408	260	30	24,8
-	2"	240	420	260	35	26

GLOBO 2500LBS SW/BW PRESSURE SEAL



DOUGLAS CHERO GLOBO Fig. 115xPS		Clase: 2500LBS
Válvula Globo Acero Carbono 2500LBS SW/BW		
Especificaciones		
Material	Acero carbono ASTM A105 ¹	
Presiones	2.500 p.s.i. a 454°C 6.170 p.s.i. a 38°C	
Pruebas	Hidráulica (mínima): Cuerpo 9.275 p.s.i. Asiento 6.800 p.s.i. Aire bajo el agua: Asiento 85 p.s.i.	
Diseño	ASME B16.34	
Normas	Construcción basada en ASME B16.34 Socket Welding ASME B16.11 Butt Welding ASME B16.25	
¹ Ver lista de materiales de construcción		

FIG. 115xPS - GLOBO A105/F6 TRIM N° 1 - 2500LBS SW PRESSURE SEAL

Código	DN	Ff (mm)	Ha (mm)	Vi (mm)	Pf (mm)	Peso (kg)
-	1/2"	110	238	120	11,0	5,7
-	3/4"	115	276	200	14,0	7,9
-	1"	130	295	200	18,0	9,2
-	1.1/4"					
-	1.1/2"	210	406	260	30,0	29,1
-	2"	240	437	350	35,0	35,0

VÁLVULAS FORJADAS PRESSURE SEAL

GLOBO 900LBS SW/BW PRESSURE SEAL

DOUGLAS CHERO GLOBO Fig. 70xPS		Clase: 900LBS
Válvula Globo Acero Carbono 900LBS SW/BW		
Especificaciones		
Material	Acero carbono ASTM A105 ¹	
Presiones	900 p.s.i. a 454°C 2.220 p.s.i. a 38°C	
Pruebas	Hidráulica (mínima): Cuerpo 3.330 p.s.i. Asiento 2.442 p.s.i. Aire bajo el agua: Asiento 85 p.s.i.	
Diseño	API 598, BS EN 12266 (Parte 1)	
Normas	Construcción basada en BS 1873 Socket Welding ASME B16.11 Butt Welding ASME B16.25	
¹ Ver lista de materiales de construcción		

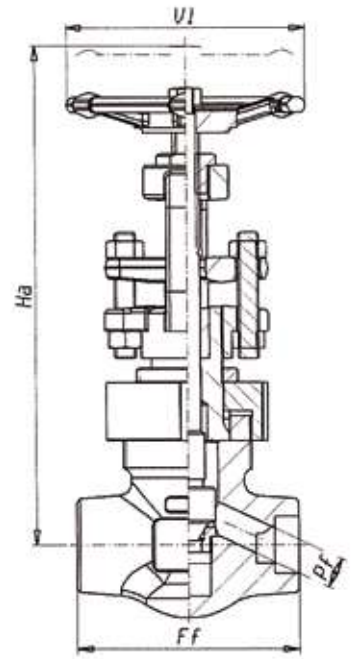
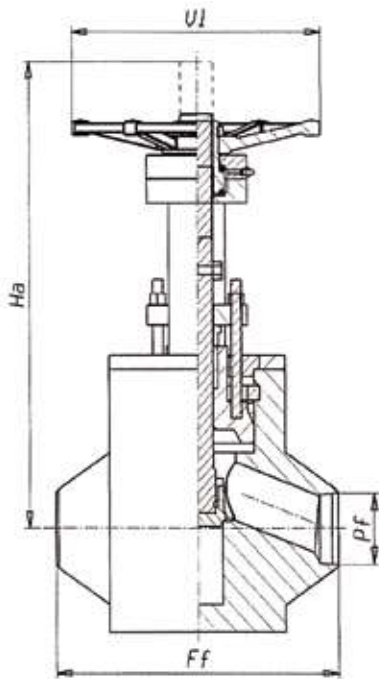

FIG. 70xPS - GLOBO A105/F6 TRIM N° 1 - 900LBS SW PRESSURE SEAL

Código	DN	Ff (mm)	Ha (mm)	VI (mm)	Pf (mm)	Peso (kg)
-	3"	305	600	350	78	90
-	4"	356	650	350	102	170
-	6"	508	750	Con Reductor	154	430
-	8"	660	1000	Con Reductor	180	750
-	10"	838	1750	Con Reductor	195	1195
-	12"	965	1970	Con Reductor	231	1910

GLOBO 1500LBS SW/BW PRESSURE SEAL



DOUGLAS CHERO GLOBO Fig. 75xPS		Clase: 1500LBS
Válvula Globo Acero Carbono 1500LBS SW/BW		
Especificaciones		
Material	Acero carbono ASTM A105 ¹	
Presiones	1.500 p.s.i. a 454°C 3.705 p.s.i. a 38°C	
Pruebas	Hidráulica (mínima): Cuerpo 5.557 p.s.i. Asiento 4.075 p.s.i. Aire bajo el agua: Asiento 85 p.s.i.	
Diseño	API 598, BS EN 12266 (Parte 1)	
Normas	Construcción basada en BS 1873 Socket Welding ASME B16.11 Butt Welding ASME B16.25	
¹ Ver lista de materiales de construcción		

FIG. 75xPS - GLOBO A105/F6 TRIM N° 1 - 1500LBS SW PRESSURE SEAL

Código	DN	Ff (mm)	Ha (mm)	U1 (mm)	Pf (mm)	Peso (kg)
-	3"	305	600	350	78	90
-	4"	406	650	350	102	170
-	6"	559	750	Con Reductor	154	430
-	8"	711	1000	Con Reductor	180	750
-	10"	991	1410	Con Reductor	195	1250
-	12"	1130	1590	Con Reductor	231	1980

VÁLVULAS FORJADAS PRESSURE SEAL

GLOBO 2500LBS SW/BW PRESSURE SEAL

DOUGLAS CHERO GLOBO Fig. 115xPS		Clase: 2500LBS
Válvula Globo Acero Carbono 2500LBS SW/BW		
Especificaciones		
Material	Acero carbono ASTM A105 ¹	
Presiones	2.500 p.s.i. a 454°C 6.170 p.s.i. a 38°C	
Pruebas	Hidráulica (mínima): Cuerpo 9.255 p.s.i. Asiento 6.787 p.s.i. Aire bajo el agua: Asiento 85 p.s.i.	
Diseño	API 598, BS EN 12266 (Parte 1)	
Normas	Construcción basada en BS 1873 Socket Welding ASME B16.11 Butt Welding ASME B16.25	
¹ Ver lista de materiales de construcción		

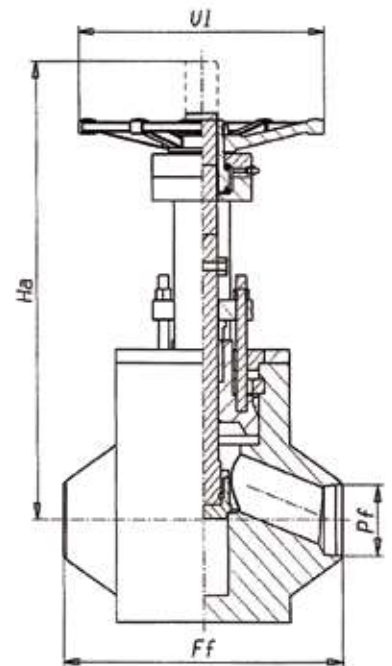
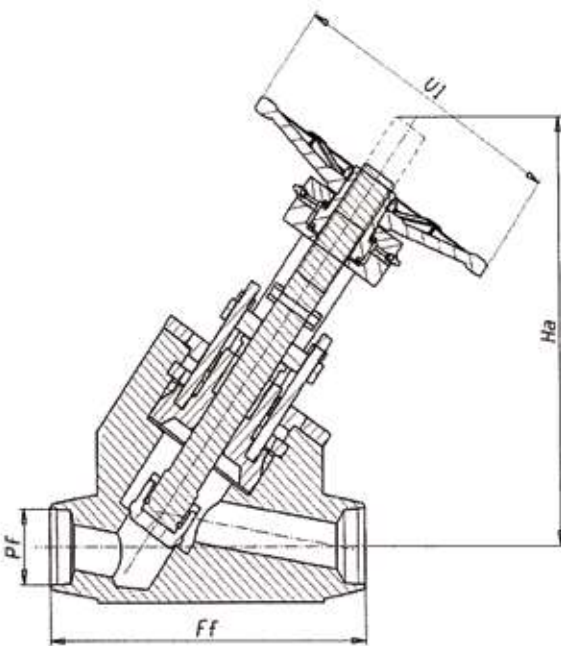

FIG. 115xPS - GLOBO A105/F6 TRIM N° 1 - 2500LBS SW PRESSURE SEAL

Código	DN	Ff (mm)	Ha (mm)	VI (mm)	Pf (mm)	Peso (kg)
-	3"	368	600	350	78	95
-	4"	457	660	Con Reductor	102	170
-	6"	610	800	Con Reductor	154	430
-	8"	762	1100	Con Reductor	180	790
-	10"	914	1500	Con Reductor	200	1500
-	12"	1041	1950	Con Reductor	220	2000

GLOBO 'Y' 900LBS SW/BW PRESSURE SEAL



DOUGLAS CHERO GLOBO 'Y' Fig. Y70xPS		Clase: 900LBS
Válvula Globo 'Y' Acero Carbono 900LBS SW/BW		
Especificaciones		
Material	Acero carbono ASTM A105 ¹	
Presiones	900 p.s.i. a 454°C 2.220 p.s.i. a 38°C	
Pruebas	Hidráulica (mínima): Cuerpo 3.330 p.s.i. Asiento 2.442 p.s.i. Aire bajo el agua: Asiento 85 p.s.i.	
Diseño	API 598, BS EN 12266 (Parte 1)	
Normas	Construcción basada en BS 1873 Socket Welding ASME B16.11 Butt Welding ASME B16.25	
¹ Ver lista de materiales de construcción		

FIG. Y70xPS - GLOBO 'Y' A105/F6 TRIM N° 1 - 900LBS SW PRESSURE SEAL

Código	DN	Ff (mm)	Ha (mm)	U1 (mm)	Pf (mm)	Peso (kg)
-	3"	350	450	350	78	90
-	4"	400	510	350	102	120
-	6"	500	630	Con Reductor	154	430
-	8"	625	825	Con Reductor	202	750

VÁLVULAS FORJADAS PRESSURE SEAL

GLOBO 'Y' 1500LBS SW/BW PRESSURE SEAL

DOUGLAS CHERO GLOBO 'Y' Fig. Y75xPS		Clase: 1500LBS
Válvula Globo 'Y' Acero Carbono 1500LBS SW/BW		
Especificaciones		
Material	Acero carbono ASTM A105 ¹	
Presiones	1.500 p.s.i. a 454°C 3.705 p.s.i. a 38°C	
Pruebas	Hidráulica (mínima): Cuerpo 5.557 p.s.i. Asiento 4.075 p.s.i. Aire bajo el agua: Asiento 85 p.s.i.	
Diseño	API 598, BS EN 12266 (Parte 1)	
Normas	Construcción basada en BS 1873 Socket Welding ASME B16.11 Butt Welding ASME B16.25	
¹ Ver lista de materiales de construcción		

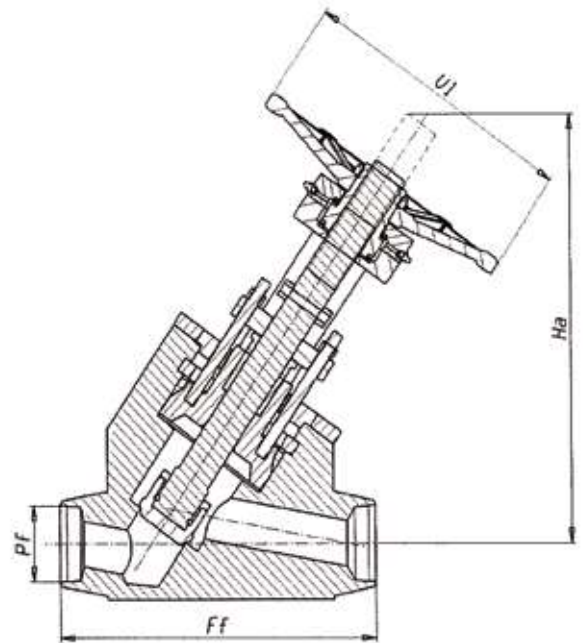
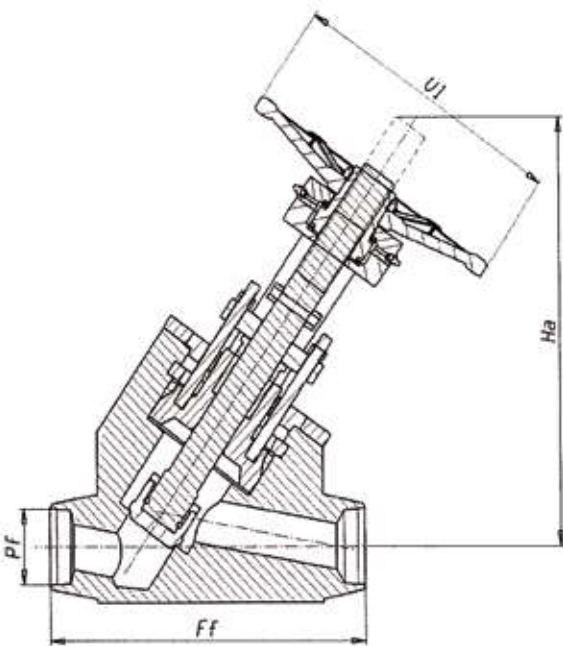

FIG. Y75xPS - GLOBO 'Y' A105/F6 TRIM N° 1 - 1500LBS SW PRESSURE SEAL

Código	DN	Ff (mm)	Ha (mm)	V1 (mm)	Pf (mm)	Peso (kg)
-	3"	350	450	350	78	90
-	4"	400	510	500	102	170
-	6"	500	630	Con Reductor	154	430
-	8"	625	825	Con Reductor	202	750

GLOBO 'Y' 2500LBS SW/BW PRESSURE SEAL



DOUGLAS CHERO GLOBO 'Y' Fig. Y115xPS		Clase: 2500LBS
Válvula Globo 'Y' Acero Carbono 2500LBS SW/BW		
Especificaciones		
Material	Acero carbono ASTM A105 ¹	
Presiones	2.500 p.s.i. a 454°C 6.170 p.s.i. a 38°C	
Pruebas	Hidráulica (mínima): Cuerpo 9.255 p.s.i. Asiento 6.787 p.s.i. Aire bajo el agua: Asiento 85 p.s.i.	
Diseño	API 598, BS EN 12266 (Parte 1)	
Normas	Construcción basada en BS 1873 Socket Welding ASME B16.11 Butt Welding ASME B16.25	
¹ Ver lista de materiales de construcción		

FIG. Y115xPS - GLOBO 'Y' A105/F6 TRIM N° 1 - 2500LBS SW PRESSURE SEAL

Código	DN	Ff (mm)	Ha (mm)	U1 (mm)	Pf (mm)	Peso (kg)
-	3"	350	450	350	78	95
-	4"	400	510	Con Reductor	102	170
-	6"	500	630	Con Reductor	154	430
-	8"	625	825	Con Reductor	202	790

VÁLVULAS FORJADAS PRESSURE SEAL

RETENCIÓN CLAPETA 1500LBS SW/BW PRESSURE SEAL

DOUGLAS CHERO RET. CLAPETA Fig. 85xPS		Clase: 1500LBS
Válvula Retención a Clapeta Acero Carbono 1500LBS SW/BW		
Especificaciones		
Material	Acero carbono ASTM A105 ¹	
Presiones	1.500 p.s.i. a 454°C 3.705 p.s.i. a 38°C	
Pruebas	Hidráulica (mínima): Cuerpo 5.575 p.s.i. Asiento 4.100 p.s.i. Aire bajo el agua: Asiento 85 p.s.i.	
Diseño	ASME B16.34	
Normas	Construcción basada en ASME B16.34 Socket Welding ASME B16.11 Butt Welding ASME B16.25	
¹ Ver lista de materiales de construcción		

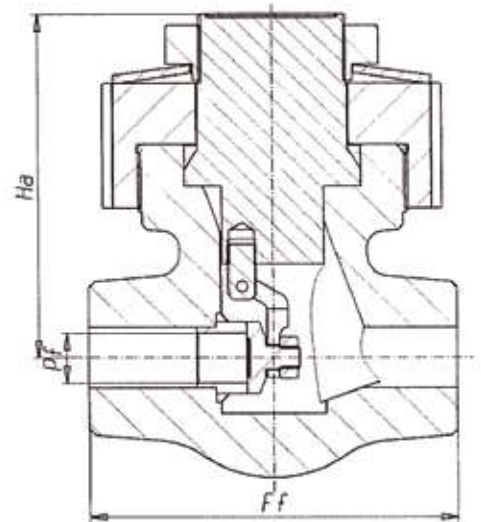
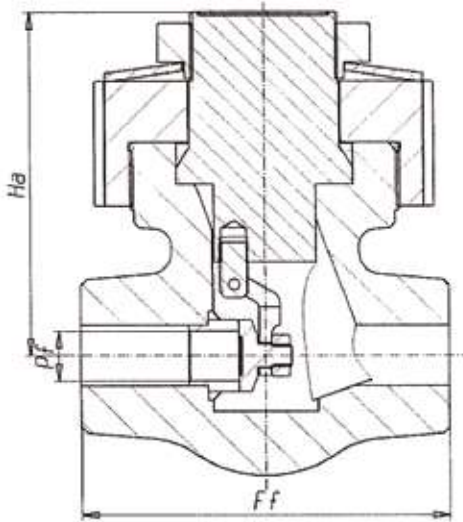

FIG. 85xPS - RETENCIÓN CLAPETA A105/F6 TRIM N° 1 - 1500LBS BW PRESSURE SEAL

Código	DN	Ff (mm)	Ha (mm)	Pf (mm)	Peso (kg)
-	1/2"	110	86	11,5	2,9
-	3/4"	115	100	15	4,2
-	1"	130	110	19,5	5,4
-	1.1/4"				
-	1.1/2"	210	153	32	17,7
-	2"	240	170	40	22

RETENCIÓN CLAPETA 2500LBS SW/BW PRESSURE SEAL



DOUGLAS CHERO RET. CLAPETA Fig. 215xPS		Clase: 2500LBS
Válvula Retención a Clapeta Acero Carbono 2500LBS SW/BW		
Especificaciones		
Material	Acero carbono ASTM A105 ¹	
Presiones	2.500 p.s.i. a 454°C 6.170 p.s.i. a 38°C	
Pruebas	Hidráulica (mínima): Cuerpo 9.275 p.s.i. Asiento 6.800 p.s.i. Aire bajo el agua: Asiento 85 p.s.i.	
Diseño	ASME B16.34	
Normas	Construcción basada en ASME B16.34 Socket Welding ASME B16.11 Butt Welding ASME B16.25	
¹ Ver lista de materiales de construcción		

FIG. 215xPS - RETENCIÓN CLAPETA A105/F6 TRIM N° 1 - 2500LBS BW PRESSURE SEAL

Código	DN	Ff (mm)	Ha (mm)	Pf (mm)	Peso (kg)
-	1/2"	110	90	10,0	2,9
-	3/4"	115	100	14	4,2
-	1"	130	124	18,0	5,4
-	1.1/4"				
-	1.1/2"	210	164	31	17,7
-	2"	240	170	36,5	22,0

VÁLVULAS FORJADAS PRESSURE SEAL

RETENCIÓN CLAPETA 900LBS SW/BW PRESSURE SEAL

DOUGLAS CHERO RET. CLAPETA Fig. 80xPS		Clase: 900LBS
Válvula Retención a Clapeta Acero Carbono 900LBS SW/BW		
Especificaciones		
Material	Acero carbono ASTM A105 ¹	
Presiones	900 p.s.i. a 454°C 2.220 p.s.i. a 38°C	
Pruebas	Hidráulica (mínima): Cuerpo 3.330 p.s.i. Asiento 2.442 p.s.i. Aire bajo el agua: Asiento 85 p.s.i.	
Diseño	BS 1873	
Normas	Construcción basada en BS 1873 Socket Welding ASME B16.11 Butt Welding ASME B16.25	
¹ Ver lista de materiales de construcción		

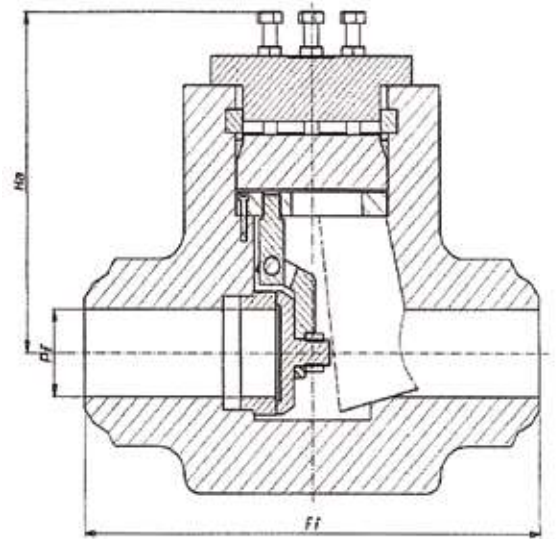
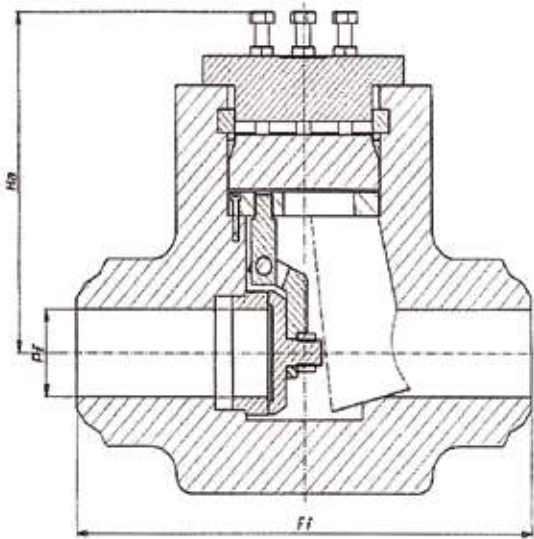

FIG. 80xPS - RETENCIÓN CLAPETA A105/F6 TRIM N° 1 - 900LBS BW PRESSURE SEAL

Código	DN	Ff (mm)	Ha (mm)	Pf (mm)	Peso (kg)
-	3"	305	220	72	70
-	4"	356	323	98	110
-	6"	508	400	146	250
-	8"	660	450	190	500
-	10"	787	505	210	880
-	12"	864	590	245	1620

RETENCIÓN CLAPETA 1500LBS SW/BW PRESSURE SEAL



DOUGLAS CHERO RET. CLAPETA Fig. 85xPS		Clase: 1500LBS
Válvula Retención a Clapeta Acero Carbono 1500LBS SW/BW		
Especificaciones		
Material	Acero carbono ASTM A105 ¹	
Presiones	1.500 p.s.i. a 454°C 3.705 p.s.i. a 38°C	
Pruebas	Hidráulica (mínima): Cuerpo 5.575 p.s.i. Asiento 4.100 p.s.i. Aire bajo el agua: Asiento 85 p.s.i.	
Diseño	API598, BS EN 12266 (Parte 1)	
Normas	Construcción basada en BS 1873 Socket Welding ASME B16.11 Butt Welding ASME B16.25	
¹ Ver lista de materiales de construcción		

FIG. 85xPS - RETENCIÓN CLAPETA A105/F6 TRIM N°1 - 1500LBS BW PRESSURE SEAL

Código	DN	Ff (mm)	Ha (mm)	Pf (mm)	Peso (kg)
-	3"	305	220	72	70
-	4"	406	323	98	110
-	6"	559	400	146	250
-	8"	711	450	190	500
-	10"	864	505	210	880
-	12"	864	590	245	1620

VÁLVULAS FORJADAS PRESSURE SEAL

RETENCIÓN CLAPETA 2500LBS SW/BW PRESSURE SEAL

DOUGLAS CHERO RET. CLAPETA Fig. 215xPS		Clase: 2500LBS
Válvula Retención a Clapeta Acero Carbono 2500LBS SW/BW		
Especificaciones		
Material	Acero carbono ASTM A105 ¹	
Presiones	2.500 p.s.i. a 454°C 6.170 p.s.i. a 38°C	
Pruebas	Hidráulica (mínima): Cuerpo 9.255 p.s.i. Asiento 6.787 p.s.i. Aire bajo el agua: Asiento 85 p.s.i.	
Diseño	API 598, BS EN 12266 (Parte 1)	
Normas	Construcción basada en BS 1873 Socket Welding ASME B16.11 Butt Welding ASME B16.25	
¹ Ver lista de materiales de construcción		

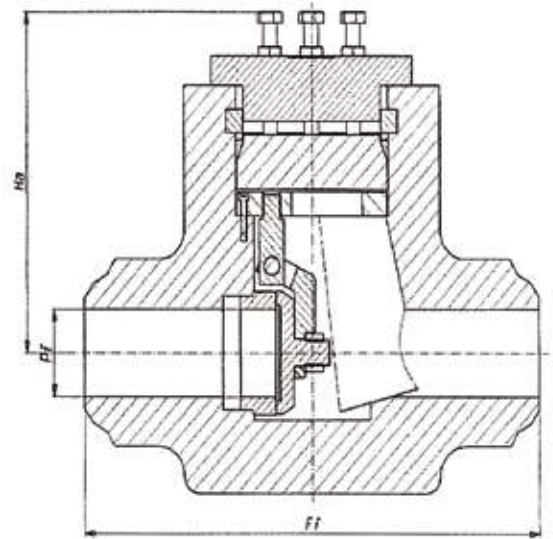

FIG. 215xPS - RETENCIÓN CLAPETA A105/F6 TRIM N° 1 - 2500LBS BW PRESSURE SEAL

Código	DN	Ff (mm)	Ha (mm)	Pf (mm)	Peso (kg)
-	3"	368	276	57	90
-	4"	457	290	75	120
-	6"	610	380	110	300
-	8"	762	486	147	700
-	10"	864	500	185	850
-	12"	864	600	218	1300

ALGUNOS DETALLES DE LA CONSTRUCCIÓN DE LAS VÁLVULAS PRESSURE SEAL

Cuña

La conexión de la cuña posee un diseño de cabeza en forma de “T”, de manera que “abraza” al husillo. El estándar de nuestras válvulas forjadas es cuña partida flexible. Gracias a este diseño, el área de contacto entre cuña y asientos es mayor.

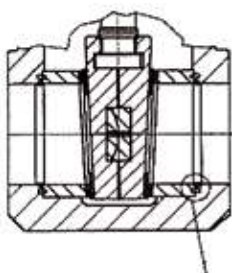

Diseño flexible estándar

Bajo demanda

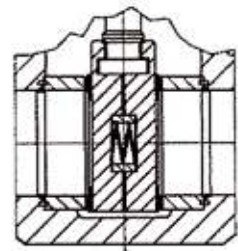

Asientos soldados

Tapa

El diseño Pressure Seal avanzado permite que la tapa sea fácilmente desmontada. El anillo segmentado permanece en la posición correcta gracias al anillo de seguridad.

La junta de grafito, alojada entre camisas de Acero inoxidable F316 a ambos lados, permite un alto grado de estanqueidad.

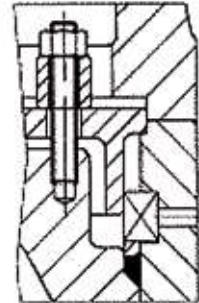

Empaquetadura

El nuevo diseño de la empaquetadura asegura el sellado mediante anillos a presión de grafito puro, junto con dos anillos de grafito trenzado en la parte superior e inferior. Al mismo tiempo, permite ser utilizado como servicio de vacío y de protección frente a emisión de partículas (“fugitive emissions”).

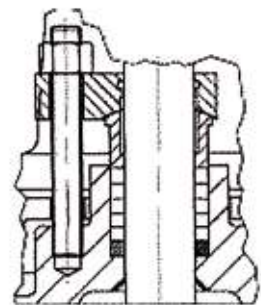





VÁLVULAS PARA ALTAS PRESIONES

VÁLVULAS PARA ALTAS PRESIONES

VÁLVULAS PARA ALTAS PRESIONES

Tipos

- » Globo
- » Interrupción / Retención
- » Globo en 'Y'
- » Globo Angular (90°)
- » Globo para Regulación
- » Retención a Clapeta
- » Retención a Pistón
- » Retención a Pistón 'Y'
- » Retención Tilting Disc
- » Retención Angular (90°)
- » Compuerta flexible
- » Doble compuerta

P
V
PICTOR
VALVES



VÁLVULAS PARA SERVICIOS ESPECIALES

- » Servicio Criogénico
- » Purga Vapor principal
- » Purga continua (agua sobrecalentada)
- » Fuelle
- » Bola Regulación
- » Diseños especiales

Accesorios

- » Columna de maniobra
- » Extensión de husillo
- » Mecanización de piezas forjadas
- » Enclavamientos
- » Indicadores de posición

Accionamientos

- » Neumático (Simple / Doble Efecto)
- » Oleohidráulico
- » Eléctrico

MATERIALES DE FABRICACIÓN

MATERIALES FORJADOS

Tipo	ASTM	DIN
Rango	800 - 4500LBS	PN25 - PN760
Acero Carbono	ASTM A105	C22.8
Baja Temperatura	ASTM A350 LF2	TT St 35 V
Acero Aleado	ASTM A182 F11 / F22 / F91	13 Cr Mo 44 / 10 Cr Mo 9.10
Acero Inoxidable	ASTM A182 F304 / F316 / F321	X10 Cr Ni Ti 18.9 / X5 Cr Ni Mo 18.10 / X10 Cr Ni Nb 18.9

MATERIALES FUNDIDOS

Tipo	ASTM	DIN
Rango	150 - 2500LBS	PN16 - PN160
Acero Carbono	ASTM A216 WCB	GSC 25 / 1.0619
Baja Temperatura	ASTM A352 LCB / LC1 / LC2	GSCK 24V / GS26 Cr Mo 4 / GS 10 Ni 14
Acero Aleado	ASTM A217 WC1 / WC5 / WC6 / WC9 / C5 / C12	GS 22 Cr Mo 4 / GS 17 Cr Mo 55 / GS 12 Cr Mo 9.10
Acero Inoxidable	ASTM A351 CF8 / CF8M / CF3 / CF3M / CF8C	GX 6 Cr N 18.9 / GX 6 Cr Ni Mo 18.10 / GX 2 Cr Ni 18.9 / GX 2 Cr Ni Mo 18.10 / GX 7 Cr Ni Nb 18.9

MATERIALES ESPECIALES

Alloy 20 / Monel / Inconel / Hastelloy B, C / Antinit / Duplex / Titanio...

RANGO DE PRESIONES

DIN

- » PN10 a PN100 (Fundición)
- » PN160 a PN420 (Fundición o Forja)
- » PN760 (Forja)

ANSI

- » 150 a 600LBS (Fundición)
- » 900 a 2500LBS (Fundición o Forja)
- » 4500LBS (Forja)

DISEÑO

PRESSURE SEAL

- » Clase 600/900/1500/2500/4500
- » PN63/100/160/250/320/420/500/760
- » **Certificaciones** (tanto en Forja como Fundición): Radiografías, Ultrasonidos, Partículas Magnéticas, Líquidos Penetrantes...
- » **TASA A (Fuga cero)** al cierre según DIN 3230 (bajo demanda)

VÁLVULAS FORJADAS THROUGH CONDUIT

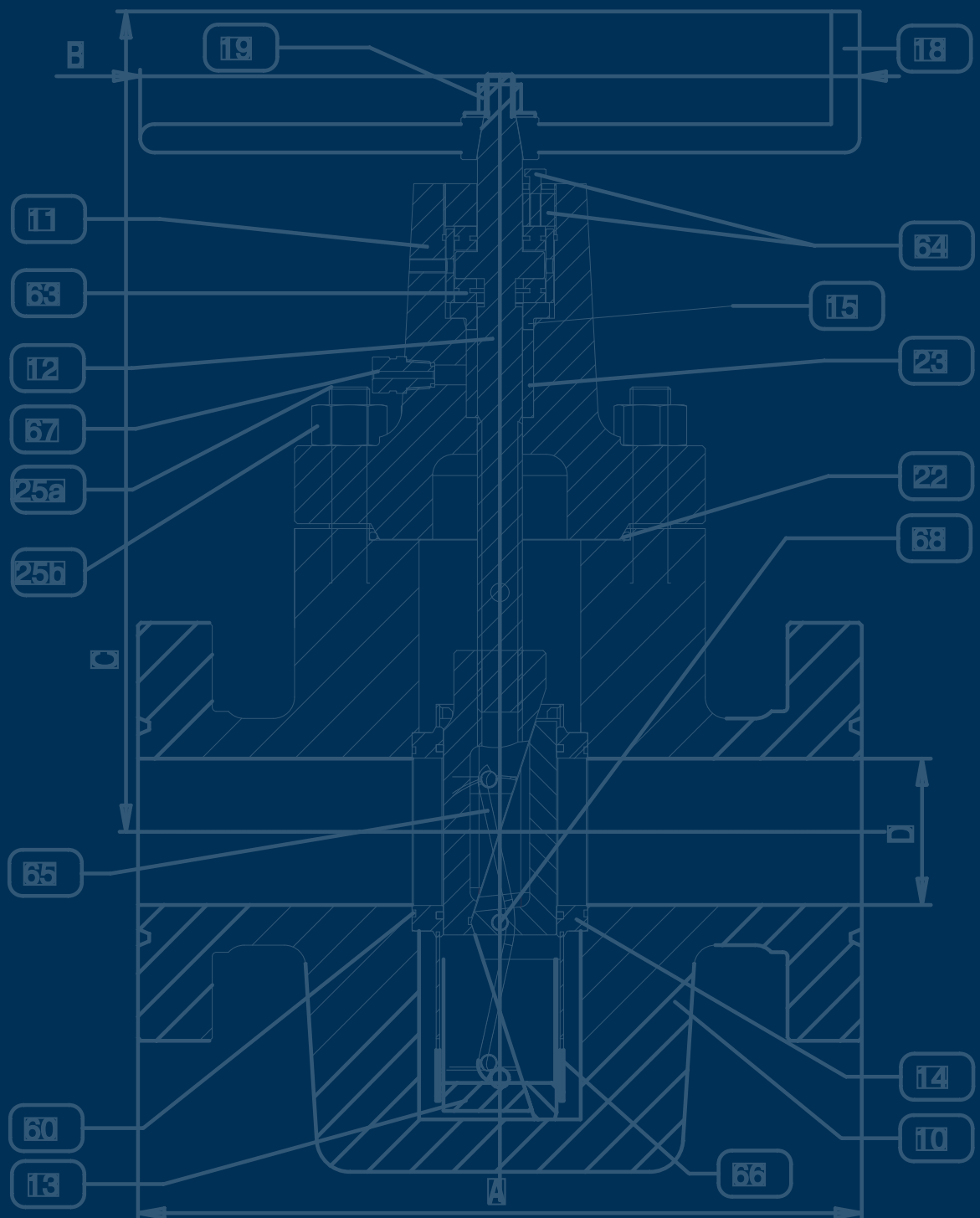



VÁLVULAS THROUGH CONDUIT



VÁLVULAS THROUGH CONDUIT

THROUGH CONDUIT 3000LBS BRIDAS API 6A / API 6D



DOUGLAS CHERO THROUGH CONDUIT		Clase: 3000LBS
Válvula Through Conduit 3000LBS		
Especificaciones		
Paso	Paso Total / Double Block and Bleed	
Asientos	Con inserto de PTFE o totalmente Metal/Metal Fire Safe	
Empaquetadura	Apta para servicio Altas Temperaturas (hasta 520° C) bajo demanda	
Accionamiento	Volante, Reductor manual, Actuador (eléctrico, hidráulico o pneumo-hidráulico)	
Normas	Hasta API 10.000	

Componentes Ejecución estándar con engrasador de husillo	
Pos.	Denominación
10	Cuerpo
11	Tapa
12	Husillo
13	Cuña
14	Asientos
15	Prensaestopas
17	Tuerca husillo
18	Volante
19	Tapón volante
22a	Junta RTJ
23	Empaquetadura
25a	Espárragos cuerpo
25b	Tuercas cuerpo
60	Junta asientos
61	Tuerca
62	Soporte cojinetes
63	Cojinete
64	Tapón husillo
65	Anillo empaquetadura
66	Cuña
67	Engrasador

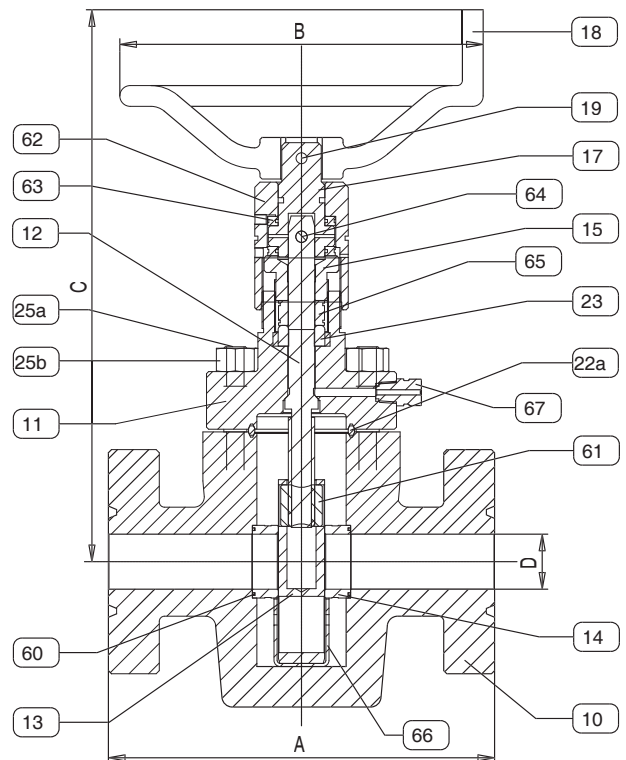

THROUGH CONDUIT 3000 P.S.I. API 6A / API 6D

Dimensiones	2.1/16"		2.9/16"		3.1/8"		4.1/16"	
	mm.	inches	mm.	inches	mm.	inches	mm.	inches
A (Dist. entre caras)	371	14.5/8"	422	16.5/8"	435	17.1/8"	511	20.1/8"
B (Diám. volante)	350	13"	350	13"	500	20"	500	20"
C (Altura)	500	19.5/8"	525	20.5/8"	580	23"	675	26.5/8"
D (Diám. de paso)	52,4	2.1/16"	65,1	2.9/16"	79,4	3.1/8"	103,2	4.1/16"
Peso aprox.	80	176	100	220	140	308	280	617

THROUGH CONDUIT 5000LBS BRIDAS API 6A / API 6D



DOUGLAS CHERO THROUGH CONDUIT		Clase: 5000LBS
Válvula Through Conduit 5000LBS		
Especificaciones		
Paso	Paso Total / Double Block and Bleed	
Asientos	Con inserto de PTFE o totalmente Metal/Metal Fire Safe	
Empaquetadura	Apta para servicio Altas Temperaturas (hasta 520° C) bajo demanda	
Accionamiento	Volante, Reductor manual, Actuador (eléctrico, hidráulico o neumohidráulico)	
Normas	Hasta API 10.000	

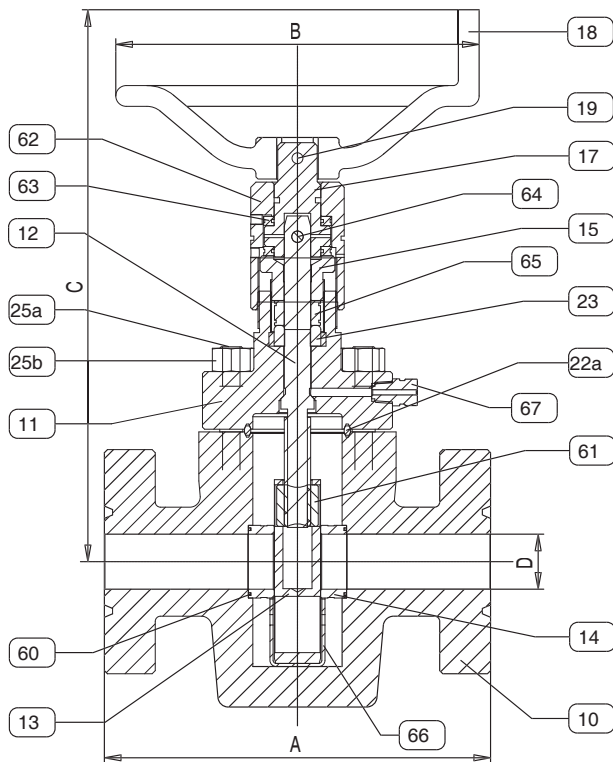

Componentes Ejecución estándar con 1 engrasador de husillo y 2 engrasadores de cuña	
Pos.	Denominación
10	Cuerpo
11	Tapa
12	Husillo
13	Conjunto cuña
14	Asientos
15	Prensaestopas
18	Volante
19	Tuerca volante
22	Junta
23	Empaquetadura
25a	Espárragos cuerpo
25b	Tuercas cuerpo
60	Junta asientos
63	Cojinete de empuje
64	Juego de tornillo y tuerca
65	Muelle
66	Cuña
67	Engrasador
68	Pasador

THROUGH CONDUIT 5000 P.S.I. API 6A / API 6D

Dimensiones	2.1/16"		2.9/16"		3.1/8"		4.1/16"	
	mm.	inches	mm.	inches	mm.	inches	mm.	inches
A (Dist. entre caras)	371	14.5/8"	422	16.5/8"	473	18.5/8"	549	21.5/8"
B (Diám. volante)	350	13"	350	13"	500	20"	500	20"
C (Altura)	500	19.5/8"	525	20.5/8"	580	23"	675	26.5/8"
D (Diám. de paso)	52,4	2.1/16"	65,1	2.9/16"	79,4	3.1/8"	103,2	4.1/16"
Peso aprox.	80	176	100	220	150	330	300	660

VÁLVULAS THROUGH CONDUIT

THROUGH CONDUIT 3000LBS BRIDAS API 6A / API 6D CUÑA PARTIDA

DOUGLAS CHERO THROUGH CONDUIT		Clase: 3000LBS
Válvula Through Conduit 3000LBS CUÑA PARTIDA		
Especificaciones		
Paso	Paso Total / Double Block and Bleed	
Asientos	Con inserto de PTFE o totalmente Metal/Metal Fire Safe	
Empaquetadura	Apta para servicio Altas Temperaturas (hasta 520° C) bajo demanda	
Accionamiento	Volante, Reductor manual, Actuador (eléctrico, hidráulico o pneumo-hidráulico)	
Normas	Hasta API 10.000	



Componentes Ejecución estándar con engrasador de husillo	
Pos.	Denominación
10	Cuerpo
11	Tapa
12	Husillo
13	Cuña
14	Asientos
15	Prensaestopas
17	Tuerca husillo
18	Volante
19	Tapón volante
22a	Junta RTJ
23	Empaquetadura
25a	Espárragos cuerpo
25b	Tuercas cuerpo
60	Junta asientos
61	Tuerca
62	Soporte cojinetes
63	Cojinete
64	Tapón husillo
65	Anillo empaquetadura
66	Cuña
67	Engrasador

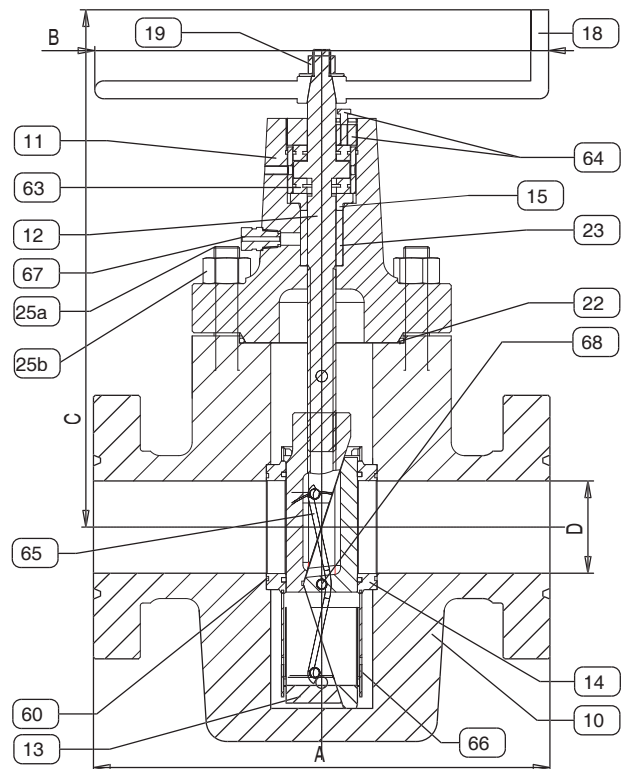

THROUGH CONDUIT 3000 P.S.I. API 6A / API 6D CUÑA PARTIDA

Dimensiones	2.1/16"		2.9/16"		3.1/8"		4.1/16"	
	mm.	inches	mm.	inches	mm.	inches	mm.	inches
A (Dist. entre caras)	371	14.5/8"	422	16.5/8"	435	17.1/8"	511	20.1/8"
B (Diám. volante)	350	13"	350	13"	500	20"	500	20"
C (Altura)	500	19.5/8"	525	20.5/8"	580	23"	675	26.5/8"
D (Diám. de paso)	52,4	2.1/16"	65,1	2.9/16"	79,4	3.1/8"	103,2	4.1/16"
Peso aprox.	80	176	100	220	140	308	280	617

THROUGH CONDUIT 5000LBS BRIDAS API 6A / API 6D CUÑA PARTIDA



DOUGLAS CHERO THROUGH CONDUIT Clase: 5000LBS

Válvula Through Conduit 5000LBS Cuña partida

Especificaciones

Paso	Paso Total / Double Block and Bleed
Asientos	Con inserto de PTFE o totalmente Metal/Metal Fire Safe
Empaquetadura	Apta para servicio Altas Temperaturas (hasta 520° C) bajo demanda
Accionamiento	Volante, Reductor manual, Actuador (eléctrico, hidráulico o neumohidráulico)
Normas	Hasta API 10.000

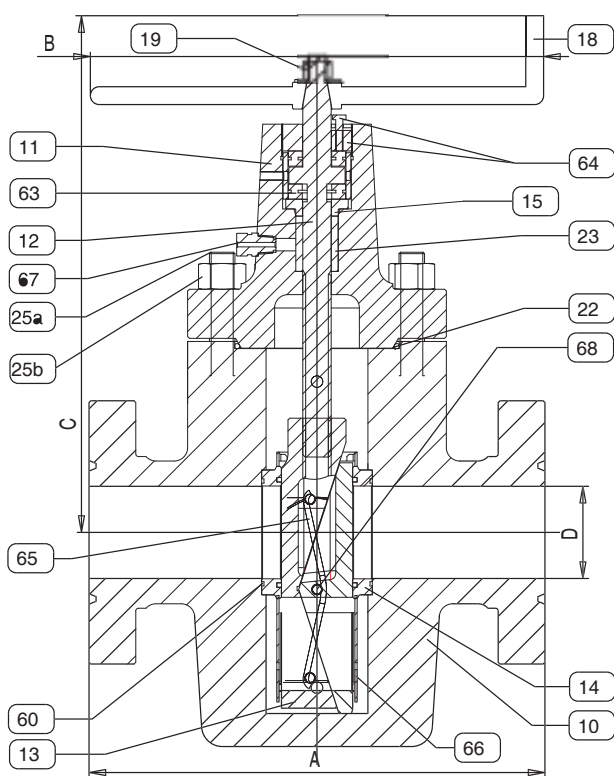

Componentes Ejecución estándar
con 1 engrasador de husillo y 2 engrasadores de cuña

Pos.	Denominación
10	Cuerpo
11	Tapa
12	Husillo
13	Conjunto cuña
14	Asientos
15	Prensaestopas
18	Volante
19	Tuerca volante
22	Junta
23	Empaquetadura
25a	Espárragos cuerpo
25b	Tuercas cuerpo
60	Junta asientos
63	Cojinete de empuje
64	Juego de tornillo y tuerca
65	Muelle
66	Cuña
67	Engrasador
68	Pasador

THROUGH CONDUIT 5000 P.S.I. API 6A / API 6D CUÑA PARTIDA

Dimensiones	2.1/16"		2.9/16"		3.1/8"		4.1/16"	
	mm.	inches	mm.	inches	mm.	inches	mm.	inches
A (Dist. entre caras)	371	14.5/8"	422	16.5/8"	473	18.5/8"	549	21.5/8"
B (Diám. volante)	350	13"	350	13"	500	20"	500	20"
C (Altura)	500	19.5/8"	525	20.5/8"	580	23"	675	26.5/8"
D (Diám. de paso)	52,4	2.1/16"	65,1	2.9/16"	79,4	3.1/8"	103,2	4.1/16"
Peso aprox.	80	176	100	220	150	330	300	660

VÁLVULAS FORJADAS SERVICIO UREA

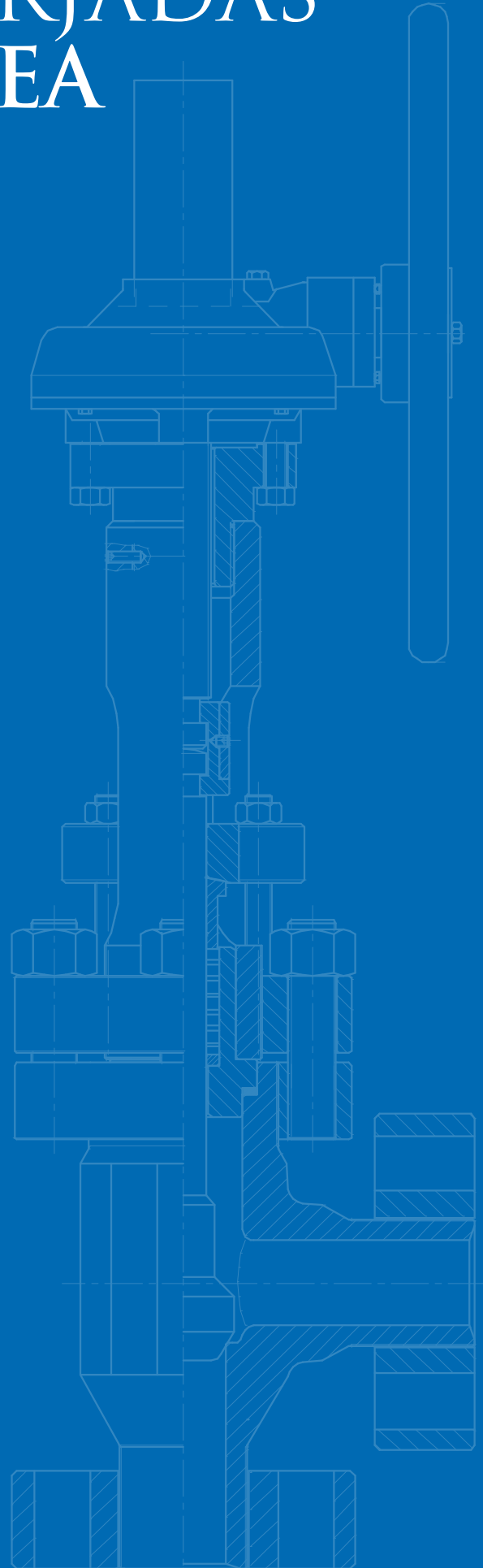



VÁLVULAS PARA SERVICIO UREA



VÁLVULAS SERVICIO UREA

RETENCIÓN SERVICIO UREA PN325 1/2" a 2"

DOUGLAS CHERO RETENCIÓN UREA		Rating: PN325
Válvula Retención Servicio Urea PN325		
Especificaciones		
Tipo	Retención "Drop check"	
Pruebas	Estándar: Cuerpo 490 bar. Asiento 360 bar	
Rating	Clase 2500LBS, PN325 y PN455	
Certificados	Con el fin de controlar el grado de corrosión del material se pueden emitir (entre otros) los siguientes certificados: Tratamiento térmico, Microestructura, Test 'Huey' (Corrosión), Contenido en ferrita, etc...	



Componentes		
Pos.	Denominación	Material
10	Medio cuerpo (asiento int.)	ASTM A182 / F316LM (Grado Urea)
11	Medio cuerpo	ASTM A182 / F316LM (Grado Urea)
12	Brida cuerpo	ASTM A105N
13	Obturador	ASTM A182 / F316LM (Grado Urea)
22	Junta anillo	ASTM A182 / F316LM (Grado Urea)
25a	Tornillos cuerpo	ASTM A193 / B7 Galvanizado
25b	Tuercas cuerpo	ASTM A194 / 2H Galvanizado
50	Placa identificación	Acero inoxidable
51	Brida	ASTM A105N

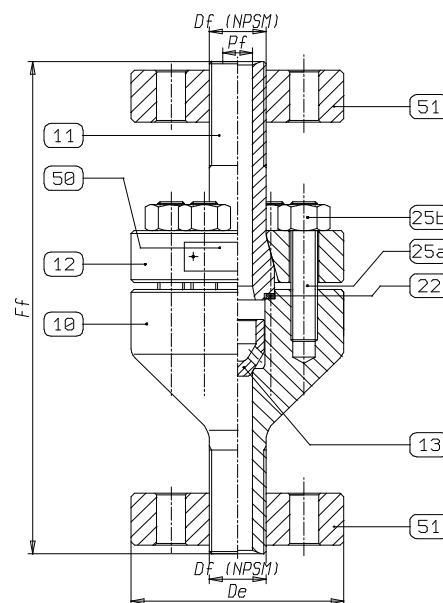

RETENCIÓN SERVICIO UREA PN325

Código	DN	Df	Pf	De	Ff	Peso (kg)
-	1/2"	1/2"	11	95	180	4,50
-	3/4"	3/4"	15	100	215	4,50
-	1"	1"	19	105	245	9,50
-	1.1/2"	1.1/2"	28	135	300	19,70
-	2"	2"	37	155	430	43,34

RETENCIÓN SERVICIO UREA PN325 3" a 10"



DOUGLAS CHERO RETENCIÓN UREA Rating: PN325

Válvula Retención Servicio Urea PN325

Especificaciones

Tipo	Retención "Drop check"
Pruebas	Estándar: Cuerpo 490 bar. Asiento 360 bar
Rating	Clase 2500LBS, PN325 y PN455
Certificados	Con el fin de controlar el grado de corrosión del material se pueden emitir (entre otros) los siguientes certificados: Tratamiento térmico, Microestructura, Test 'Huey' (Corrosión), Contenido en ferrita, etc...

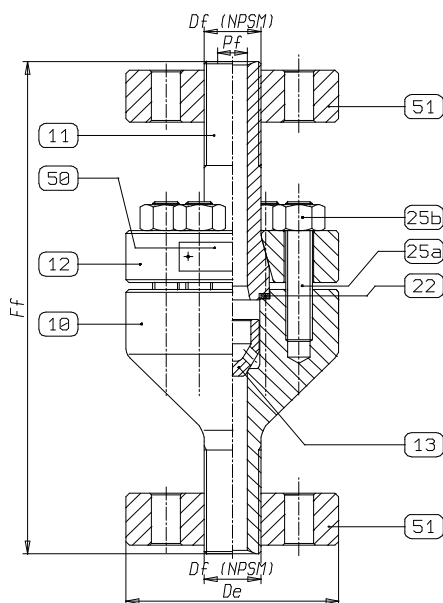

Componentes		
Pos.	Denominación	Material
10	Medio cuerpo (asiento int.)	ASTM A182 / F316LM (Grado Urea)
11	Medio cuerpo	ASTM A182 / F316LM (Grado Urea)
12	Brida cuerpo	ASTM A105N
13	Obturador	ASTM A182 / F316LM (Grado Urea)
22	Junta anillo	ASTM A182 / F316LM (Grado Urea)
25a	Tornillos cuerpo	ASTM A193 / B7 Galvanizado
25b	Tuercas cuerpo	ASTM A194 / 2H Galvanizado
50	Placa identificación	Acero inoxidable
51	Brida	ASTM A105N

RETENCIÓN SERVICIO UREA PN325

Código	DN	Df	Pf	De	Ff	Peso (kg)
-	3"	3"	58	200	485	76
-	4"	4"	73	250	560	130
-	6"	6"	102	330	800	315
-	8"	8"	135	410	900	560
-	10"	10"	180	480	1205	1100

VÁLVULAS SERVICIO UREA

BLOQUE ANGULAR SERVICIO UREA PN325



BLOQUE ANGULAR SERVICIO UREA		Rating: PN325
Válvula Bloque Angular Servicio Urea PN325		
Especificaciones		
Tipo	Paso Angular	
Pruebas	Estándar: Cuerpo 490 bar. Asiento 360 bar. Aire 6 bar	
Rating	Clase 2500LBS, PN325 y PN455	
Certificados	Con el fin de controlar el grado de corrosión del material se pueden emitir (entre otros) los siguientes certificados: Tratamiento térmico, Microestructura, Test 'Huey' (Corrosión), Contenido en ferrita, etc...	

Componentes		
Pos.	Denominación	Material
10	Cuerpo (asiento interior)	ASTM A182 / F316LM (Grado Urea)
11a	Cuerpo caja prensaestopas	ASTM A182 / F316LM (Grado Urea)
11b	Extensión tapa	ASTM A105N
12a	Husillo	Ferralium Alloy 255
12b	Husillo superior	ASTM A182 F6a
15	Prensaestopas	ASTM A182 / F316LM (Grado Urea)
16	Brida prensaestopas	ASTM A105N
17	Tuerca husillo	Hierro Fundido Ni-resist
18	Volante	Acero carbono
19	Tuerca volante	Acero carbono
22	Junta anillo	ASTM A182 / F316LM (Grado Urea)
23	Empaquetadura	Grafito preformado
26	Arandela volante	Acero carbono
37	Casquillo prensa	ASTM A182 F316
38	Arandela empaquetadura	ASTM A182 / F316LM (Grado Urea)
45a	Manguito partido	Acero templado
45b	Anillo manguito partido	AlSi 410
46	Tornillo prisionero	Acero carbono
47	Tornillo prisionero	Acero carbono
50	Placa identificación	Acero inoxidable
51	Tuerca cuerpo	ASTM A105N

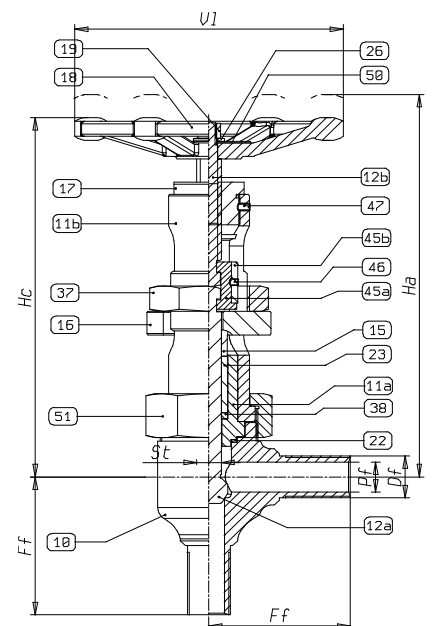

BLOQUE ANGULAR SERVICIO UREA PN325 R.MACHO

Código	DN	Df	Pf	St	Hc	Ha	Ff	VI	Peso (kg)
-	1/2"	1/2"	10	14,3	270	290	100	120	9,0
-	3/4"	3/4"	15	19,0	292	312	110	200	10,5
-	1"	1"	20	19,0	290	315	110	200	10,5

BLOQUE ANGULAR SERVICIO UREA PN325



BLOQUE ANGULAR SERVICIO UREA		Rating: PN325
Válvula Bloque Angular Servicio Urea PN325		
Especificaciones		
Tipo	Paso Angular	
Pruebas	Estándar: Cuerpo 490 bar. Asiento 360 bar. Aire 6 bar	
Rating	Clase 2500LBS, PN325 y PN455	
Certificados	Con el fin de controlar el grado de corrosión del material se pueden emitir (entre otros) los siguientes certificados: Tratamiento térmico, Microestructura, Test 'Huey' (Corrosión), Contenido en ferrita, etc...	

Componentes		
Pos.	Denominación	Material
10	Cuerpo	ASTM A182 / F316LM (Grado Urea)
11a	Cuerpo caja prensaestopas	ASTM A182 / F316LM (Grado Urea)
11b	Extensión cuerpo	ASTM A105N
12a	Husillo	Ferralium Alloy 255
12b	Husillo superior	ASTM A182 F6a
15	Prensaestopas	ASTM A182 / F316LM (Grado Urea)
16	Brida prensaestopas	ASTM A105N
17	Tuerca husillo	Hierro Fundido Ni-Resist
18	Volante	Acero carbono
20	Espárrago prensa	ASTM A193 B8
21	Tuerca prensa	ASTM A194 Gr.8
22	Junta anillo	ASTM A182 / F316LM (Grado Urea)
23	Empaquetadura	Grafito preformado
25a	Tornillos cuerpo	ASTM A193 B7 Galvanizado
25b	Tuercas cuerpo	ASTM A194 2H Galvanizado
38	Arandela empaquetadura	ASTM A182 / F316LM (Grado Urea)
45a	Manguito partido	Acero templado
45b	Anillo manguito partido	AISI 410
46	Tornillo prisionero	Acero carbono
47	Tornillo prisionero	Acero carbono
50	Placa identificación	Acero inoxidable
51	Brida inferior cuerpo	ASTM A105N
52	Brida superior cuerpo	ASTM A105N
53	Reductor manual	-
54	Tornillos reductor	Acero carbono

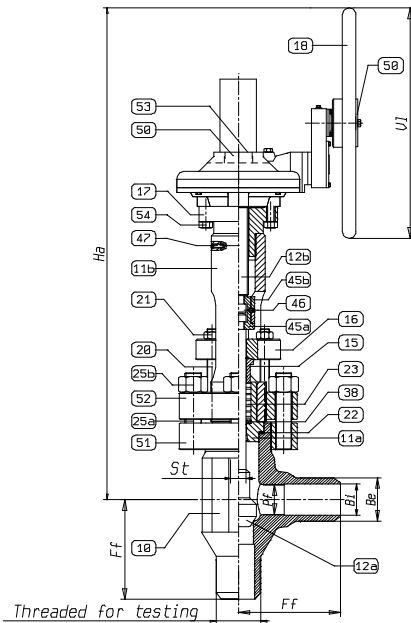

RETENCIÓN SERVICIO UREA PN325 BW¹

Código	DN	Bi	Be	Pf	St	Ha	Ff	VI	Peso (kg)
-	4"	92,0	115	73	40	1140	260	600	270
-	6"	136,5	169	110	54	1715	310	600	575

⁽¹⁾ 4" BW Sch.120 | 6" BW Sch.160

VÁLVULAS SERVICIO UREA

BLOQUE ANGULAR SERVICIO UREA 2500LBS



BLOQUE ANGULAR SERVICIO UREA		Clase: 2500
Válvula Bloque Angular Servicio Urea 2500LBS		
Especificaciones		
Tipo	Paso Angular	
Pruebas	Estándar: Cuerpo 490 bar. Asiento 360 bar. Aire 6 bar	
Rating	Clase 2500LBS, PN325 y PN455	
Certificados	Con el fin de controlar el grado de corrosión del material se pueden emitir (entre otros) los siguientes certificados: Tratamiento térmico, Microestructura, Test 'Huey' (Corrosión), Contenido en ferrita, etc...	

Componentes		
Pos.	Denominación	Material
10	Cuerpo	ASTM A182 / F316LM (Grado Urea)
11a	Cuerpo caja prensaestopas	ASTM A182 / F316LM (Grado Urea)
11b	Extensión cuerpo	ASTM A105N
12a	Husillo	Ferralium Alloy 255
12b	Husillo superior	ASTM A182 F6a
15	Prensaestopas	ASTM A182 / F316LM (Grado Urea)
16	Brida prensaestopas	ASTM A105N
17	Tuerca husillo	Hierro Fundido Ni-Resist
18	Volante	Acero carbono
20	Espárrago prensa	ASTM A193 B8
21	Tuerca prensa	ASTM A194 Gr.8
22	Junta anillo	ASTM A182 / F316LM (Grado Urea)
23	Empaquetadura	Grafito preformado
25a	Tornillos cuerpo	ASTM A193 B7 Galvanizado
25b	Tuercas cuerpo	ASTM A194 2H Galvanizado
38	Arandela empaquetadura	ASTM A182 / F316LM (Grado Urea)
45a	Manguito partido	Acero templado
45b	Anillo manguito partido	AISI 410
46	Tornillo prisionero	Acero carbono
47	Tornillo prisionero	Acero carbono
50	Placa identificación	Acero inoxidable
51	Brida inferior cuerpo	ASTM A105N
52	Brida superior cuerpo	ASTM A105N
53	Reductor manual	-
54	Tornillos reductor	Acero carbono
55	Brida	ASTM A105N

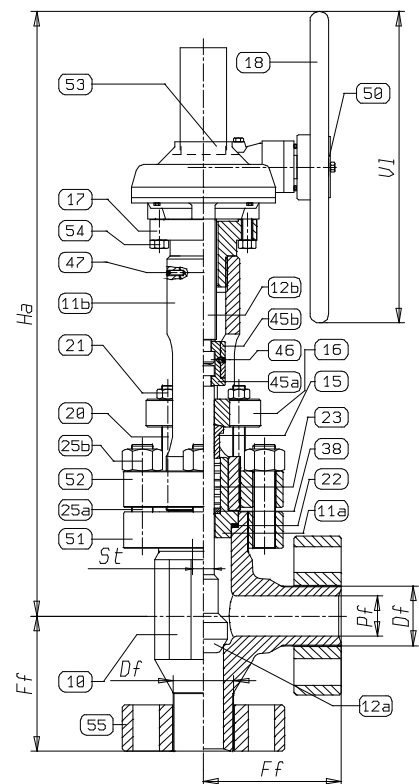

BLOQUE ANGULAR SERVICIO UREA 2500LBS BRIDAS

Código	DN	Df	Pf	St	Ha	Ff	V1	Peso (kg)
-	4"	4"	73	40	1140	260	600	270
-	6"	6"	110	54	1715	310	600	575
-	8"	8"	135	73	1842	360	800	780
-	10"	10"	180	83	2020	500	800	2050

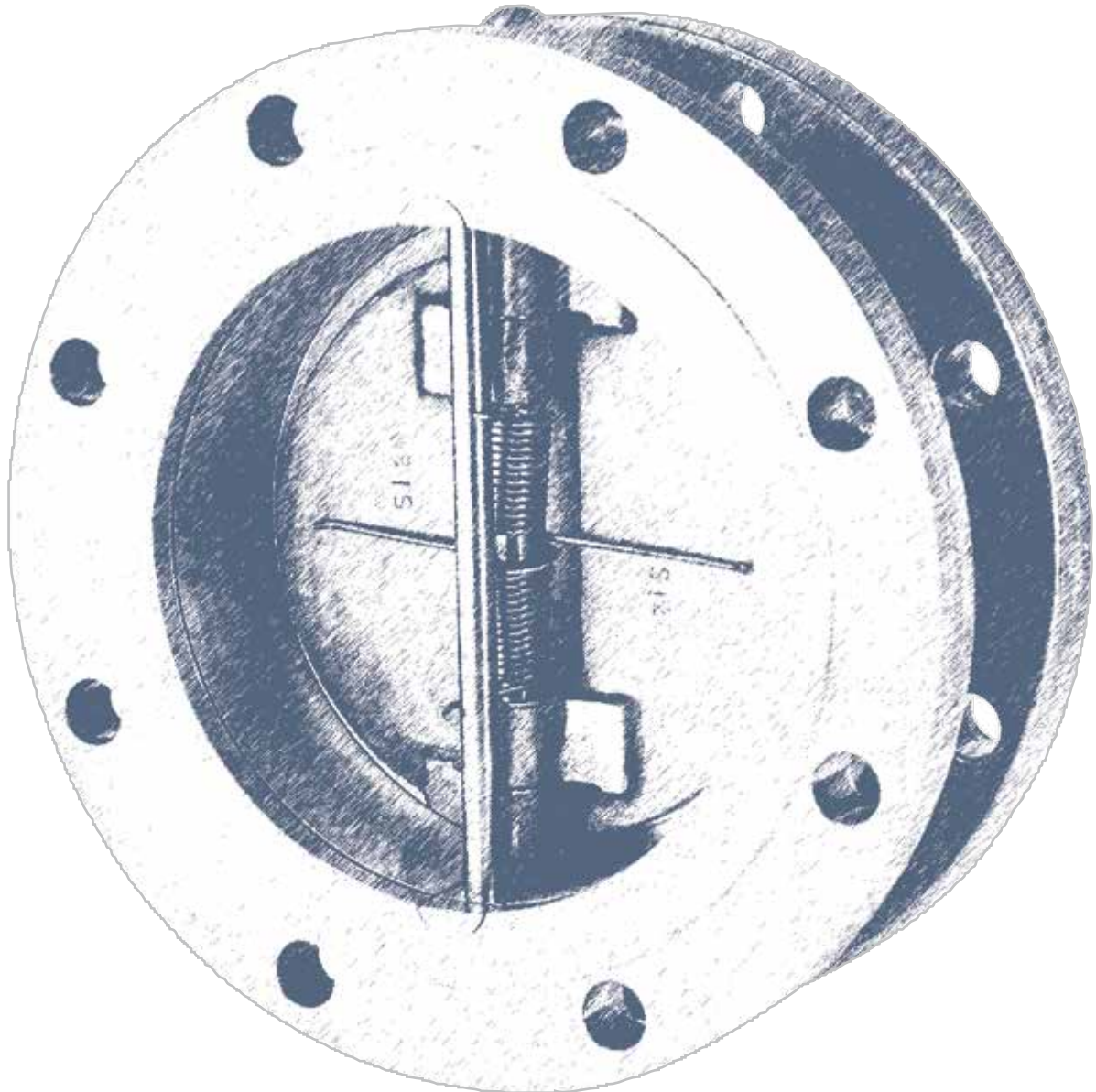

CHECKVALVES

VÁLVULAS DE RETENCIÓN DISCO DUO-CHEK®

CRANE®



High Performance Non-Slam **Check Valves**



VÁLVULAS RETENCIÓN DISCO



VÁLVULAS RETENCIÓN DISCO

CRANE® Retención	Tipo: Duo-Chek®
Válvula Retención High Performance Non-Slam	
Especificaciones	
Materiales cuerpo	Hierro Fundido, Acero carbono WCB, Acero inox. 316 y todo tipo de Aleaciones
Materiales asientos	EPDM, Buna-N, Neopreno, Elastómero para Refrigeración, Viton®, etc.
Presiones	ASME Clase 125 a 2500, API 6A, API 6D
Tipos	Wafer, Lug, Doble Brida y Cuerpo extendido
Normas	DIN, JIS, BS, AS e ISO
Conexiones	Raised Face, Plain Face, Ring Joint, Weld-End, Hub-End

Petroleum Refining

- » Hydrogen
- » Cracking
- » Steam
- » Crude oil
- » Gasoline
- » Visbreakers
- » Naptha
- » Sulphur

Oil and Gas Production

- » Centrifugal Compressor Discharge
- » Fire Water Lines
- » Oil/Steam Separation
- » Steam and CO₂ Injection
- » Gas/Oil Gathering Systems
- » Flowlines
- » Wellheads

Petrochemicals

- » Ethylene
- » Propylene
- » Steam
- » Reboilers
- » Gases

Chemicals

- » Chlorine
- » Phosgene
- » Aromatics
- » Polymers
- » Acids
- » Air Separation
- » Caustics

Power Generation

- » Steam
- » Condensate
- » Boiler Feed Pumps
- » Cooling Towers
- » Service Water Recirculators
- » River Water Intake

Steel / Primary Metals

- » Quench Lines
- » De-Scaling
- » Continuous Casters
- » Steam
- » Condensate
- » Strippers
- » Electro-Galvanizing

APLICACIONES EN LA INDUSTRIA

Marine

- » Oil Tankers
- » Tanker Loading Terminals
- » Offshore Platforms
- » Sub-Sea Manifolds
- » Terminal Transfer Lines
- » Barge Unloading Lines
- » Shipboard Services

Water and Wastewater

- » Distribution Lines
- » Pumping Stations
- » Sewage Plant Blower Discharge
- » Chemical Treatment
- » Fire Protection Systems
- » HVAC Systems

Pulp and Paper

- » Bleaching Lines
- » Black Liquor
- » Green Liquor
- » White Water
- » Steam
- » Chemical Recovery



VÁLVULAS RETENCIÓN DISCO

RETENCIÓN DISCO TIPO WAFER

CRANE® Retención		Tipo: Duo-Chek®
Válvula Retención High Performance Non-Slam		
Especificaciones		
Materiales cuerpo	Hierro Fundido, Acero carbono WCB, Acero inox. 316 y todo tipo de Aleaciones	
Materiales asientos	EPDM, Buna-N, Neopreno, Elastómero para Refrigeración, Viton®, etc.	
Presiones	ASME Clase 125 a 2500, API 6A, API 6D	
Tipos	Wafer, Lug, Doble Brida y Cuerpo extendido	
Normas	DIN, JIS, BS, AS e ISO	
Conexiones	Raised Face, Plain Face, Ring Joint, Weld-End, Hub-End	

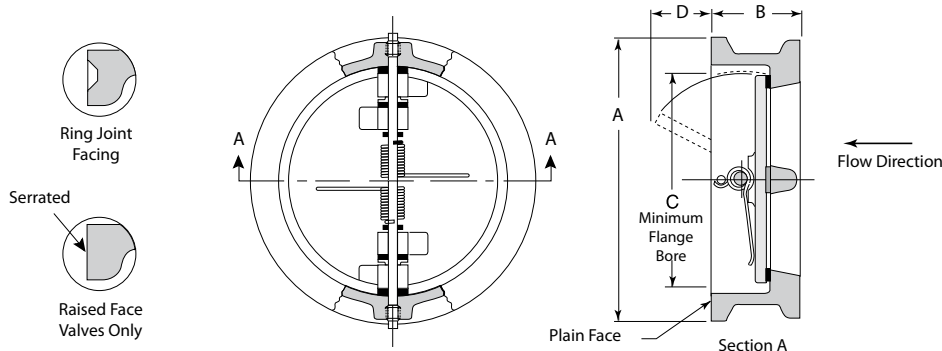

RETENCIÓN DISCO WAFER ASME CLASE 125¹

Tamaño	A	B	C	D	Peso (kg)	
In. mm.						
2"	50	105	54	52	-	1.8
2.1/2"	65	124	54	63	-	2.7
3"	80	137	57	78	16	3.2
4"	100	175	64	102	25	5.4
5"	125	197	70	127	33	6.8
6"	150	222	76	154	35	9.0
8"	200	279	95	203	54	18
10"	250	340	108	254	70	29
12"	300	410	143	303	83	50
14"	350	451	184	318	83	83
16"	400	514	191	381	113	116
18"	450	549	203	429	137	143
20"	500	606	213	478	160	172
24"	600	718	222	575	210	261
30"	750	883	305	743	229	486
36"	900	1048	368	889	303	890
42"	1050	1219	432	1041	381	1270
48"	1200	1384	524	1194	425	1178
54"	1350	1549	540	1308	502	2800
60"	1500	1715	660	1422	-	3538
66"	1650	1886	787	1657	-	5443
72"	1800	2051	914	1727	-	6350

¹ Sólo para válvulas en Hierro Fundido

RETENCIÓN DISCO WAFER ASME CLASE 150

Tamaño	A	B	C	D	Peso (kg)	
In. mm.						
2"	50	105	60	49	-	3
2.1/2"	65	124	67	60	-	5
3"	80	137	73	74	6	6
4"	100	175	73	97	16	8
5"	125	197	86	122	22	12
6"	150	222	98	146	35	16
8"	200	279	127	194	54	32
10"	250	340	146	243	70	48
12"	300	410	181	289	83	78
14"	350	451	184	318	83	91
16"	400	514	191	381	113	125
18"	450	549	203	429	137	143
20"	500	606	219	478	160	197
24"	600	718	222	575	210	281
26"	650	775	356	616	203	705
30"	750	883	330	743	229	558
36"	900	1048	387	889	303	915
42"	1050	1219	432	1041	381	1270
48"	1200	1384	524	1194	425	1178
54"	1350	1549	540	1308	502	2800
60"	1500	1715	660	1422	-	3538
66"	1650	1886	787	1657	-	5443
72"	1800	2051	914	1727	-	6350

RETENCIÓN DISCO WAFER ASME CLASE 300

Tamaño		A	B	C	D	Peso (kg)
In.	mm.					
2"	50	111	60	49	-	3
2.1/2"	65	130	67	60	-	5
3"	80	149	73	74	6	7
4"	100	181	73	97	16	8
5"	125	216	86	122	22	16
6"	150	251	98	146	35	20
8"	200	308	127	194	54	37
10"	250	362	146	243	70	57
12"	300	422	181	289	83	91
14"	350	486	222	318	81	147
16"	400	540	232	364	105	188
18"	450	597	264	429	122	252
20"	500	654	292	456	143	329
24"	600	775	318	548	179	499
26"	650	835	356	619	203	728
30"	750	953	368	730	230	930
36"	900	1118	483	889	284	1621
42"	1050	1289	568	1041	375	2622
48"	1200	1492	629	1194	419	2981

RETENCIÓN DISCO WAFER ASME CLASE 600

Tamaño		A	B	C	D	Peso (kg)
In.	mm.					
2"	50	111	60	49	-	3
2.1/2"	65	130	67	60	3	5
3"	80	149	73	74	6	7
4"	100	194	79	97	22	12
5"	125	241	105	122	25	22.7
6"	150	267	137	146	36	36
8"	200	321	165	194	51	61
10"	250	400	213	243	58	108
12"	300	457	229	289	88	151
14"	350	492	273	318	70	206
16"	400	565	305	364	110	290
18"	450	613	362	410	94	404
20"	500	683	368	456	135	508
24"	600	791	438	548	167	925
26"	650	867	547	610	184	1148
30"	750	972	505	730	243	1531
36"	900	1130	635	857	303	2858
42"	1050	1295	702	1003	362	3832

RETENCIÓN DISCO WAFER ASME CLASE 900

Tamaño		A	B	C	D	Peso (kg)
In.	mm.					
2"	50	143	70	43	-	6
2.1/2"	65	165	83	54	2	7
3"	80	168	83	67	8	11
4"	100	206	102	87	14	18
5"	125	248	-	110	-	-
6"	150	289	159	132	27	52
8"	200	359	206	173	36	104
10"	250	435	241	216	46	176
12"	300	498	292	257	59	245
14"	350	521	356	292	51	420
16"	400	575	384	325	67	523
18"	450	638	451	367	65	598
20"	500	699	451	456	135	647
24"	600	838	495	546	143	1238

RETENCIÓN DISCO WAFER ASME CLASE 1500

Tamaño		A	B	C	D	Peso (kg)
In.	mm.					
2"	50	143	70	43	-	6
2.1/2"	65	165	83	54	2	7
3"	80	175	83	67	8	11
4"	100	210	102	87	14	20
5"	125	254	-	110	-	-
6"	150	283	159	132	27	50
8"	200	352	206	173	36	99
10"	250	435	248	216	43	180
12"	300	521	305	257	57	329
14"	350	578	356	292	51	430
16"	400	641	381	325	67	627
18"	450	705	468	349	68	863
20"	500	756	533	375	102	1247
24"	600	902	559	384	105	2658

RETENCIÓN DISCO WAFER ASME CLASE 2500

Tamaño		A	B	C	D	Peso (kg)
In.	mm.					
2"	50	146	70	43	-	7
2.1/2"	65	168	83	54	2	10
3"	80	197	86	67	6	14
4"	100	235	105	87	11	25
5"	125	279	-	110	-	-
6"	150	318	159	132	27	86
8"	200	387	206	173	43	129
10"	250	476	254	216	46	228
12"	300	549	305	257	56	437

VÁLVULAS RETENCIÓN DISCO

RETENCIÓN DISCO TIPO DOBLE BRIDA

CRANE® Retención		Tipo: Duo-Chek®
Válvula Retención High Performance Non-Slam		
Especificaciones		
Materiales cuerpo	Hierro Fundido, Acero carbono WCB, Acero inox. 316 y todo tipo de Aleaciones	
Materiales asientos	EPDM, Buna-N, Neopreno, Elastómero para Refrigeración, Viton®, etc.	
Presiones	ASME Clase 125 a 2500, API 6A, API 6D	
Tipos	Wafer, Lug, Doble Brida y Cuerpo extendido	
Normas	DIN, JIS, BS, AS e ISO	
Conexiones	Raised Face, Plain Face, Ring Joint, Weld-End, Hub-End	



Componentes	
Pos.	Denominación
1	Cuerpo
2	Obturador
3	Sellado
4	Pasador
5	Bulón
6	Muelle
7	Inserto pasador
8	Anillo retén
9	Cojinete cuerpo
10	Cojinete pletina
11	Cojinete muelle

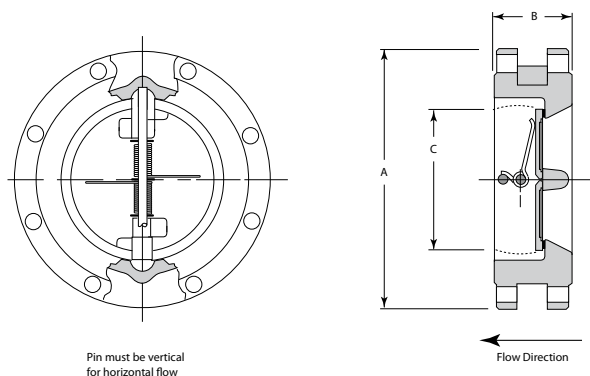
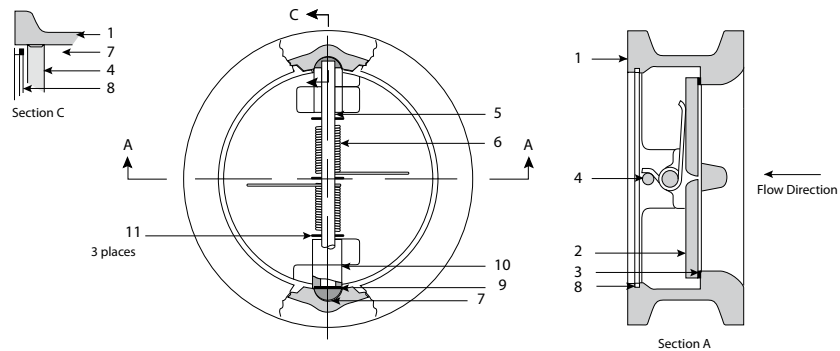

RETENCIÓN DOBLE BRIDA ASME CLASE 150

Tamaño		A	B	C	Peso (kg)
in.	mm.				
8"	200	343	127	194	42
10"	250	406	146	243	86
12"	300	483	181	289	99
14"	350	533	184	318	124
16"	400	597	191	381	160
18"	450	635	203	428	185
20"	500	699	219	480	250
24"	600	813	222	575	389
30"	750	984	330	743	687
36"	900	1168	387	889	1145
42"	1050	1346	432	1041	1888
48"	1200	1511	524	1194	2667
54"	1350	1683	539	1308	-
60"	1500	1854	660	1422	-
66"	1650	2032	787	1588	-
72"	1800	2197	914	1727	-

RETENCIÓN DOBLE BRIDA ASME CLASE 600

Tamaño		A	B	C	Peso (kg)
in.	mm.				
12"	300	559	229	289	277
14"	350	603	273	318	309
16"	400	685	305	365	430
18"	450	743	362	409	553
20"	500	813	368	457	728
24"	600	940	445	548	1111
30"	750	1130	505	730	1735
36"	900	1314	635	8575	2747
42"	1050	1403	702	1003	4529
48"	1200	1594	787	914	5715

RETENCIÓN DOBLE BRIDA ASME CLASE 300

Tamaño		A	B	C	Peso (kg)
in.	mm.				
12"	300	521	181	289	152
14"	350	584	222	318	195
16"	400	648	232	365	280
18"	450	711	264	409	385
20"	500	775	292	454	488
24"	600	914	318	562	686
30"	750	1092	368	730	1406
36"	900	1270	483	864	2109
42"	1050	1289	568	1041	3932
48"	1200	1467	629	1193	4513
54"	1350	1657	692	1308	-
60"	1500	1854	826	1422	-

RETENCIÓN DOBLE BRIDA ASME CLASE 900

Tamaño		A	B	C	Peso (kg)
in.	mm.				
12"	300	610	292	257	349
14"	350	641	356	292	561
16"	400	705	384	327	548
18"	450	787	451	368	835
20"	500	857	451	457	1787
24"	600	1041	495	546	1893
30"	750	1222	635	660	2948
36"	900	1461	711	787	-
42"	1050	1562	800	914	-

» Las medidas que aquí no aparecen pueden ser suministradas con diseño Lug (ver página siguiente). Otros tamaños o presiones, consultar.

VÁLVULAS RETENCIÓN DISCO

RETENCIÓN DISCO TIPO LUG

CRANE® Retención		Tipo: Duo-Chek®
Válvula Retención High Performance Non-Slam		
Especificaciones		
Materiales cuerpo	Hierro Fundido, Acero carbono WCB, Acero inox. 316 y todo tipo de Aleaciones	
Materiales asientos	EPDM, Buna-N, Neopreno, Elastómero para Refrigeración, Viton®, etc.	
Presiones	ASME Clase 125 a 2500, API 6A, API 6D	
Tipos	Wafer, Lug, Doble Brida y Cuerpo extendido	
Normas	DIN, JIS, BS, AS e ISO	
Conexiones	Raised Face, Plain Face, Ring Joint, Weld-End, Hub-End	

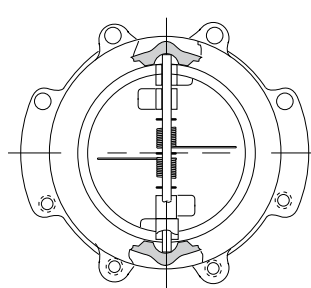

Scallop

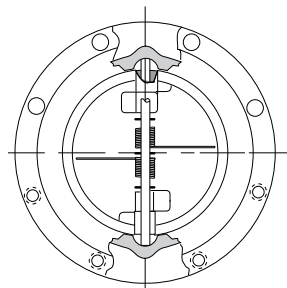

Full Body

Pin must be vertical for horizontal flow.

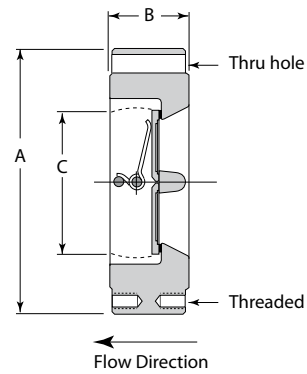

RETENCIÓN LUG ASME CLASE 150¹

Tamaño		A	B	C	Peso (kg)
In.	mm.				
2"	50	152	60	49	8
2.1/2"	65	191	67	60	8
3"	80	210	73	74	8
4"	100	229	73	97	13
5"	125	254	86	122	16
6"	150	279	98	146	22

RETENCIÓN LUG ASME CLASE 600¹

Tamaño		A	B	C	Peso (kg)
In.	mm.				
2"	50	152	60	49	8
2.1/2"	65	191	67	60	10
3"	80	210	73	74	14
4"	100	273	79	97	23
6"	150	356	137	146	83
8"	200	419	165	194	134
10"	250	508	213	243	245

RETENCIÓN LUG ASME CLASE 300¹

Tamaño		A	B	C	Peso (kg)
In.	mm.				
2"	50	152	60	49	8
2.1/2"	65	191	67	60	10
3"	80	210	73	74	14
4"	100	254	73	97	16
5"	125	279	86	122	23
6"	150	318	98	146	38
8"	200	381	127	194	61
10"	250	445	146	243	123

RETENCIÓN LUG ASME CLASE 900¹

Tamaño		A	B	C	Peso (kg)
In.	mm.				
2"	50	216	70	43	17
3"	80	241	83	67	26
4"	100	292	102	87	45
6"	150	381	159	132	114
8"	200	470	206	173	200
10"	250	546	241	216	357

(1) Otros tamaños y presiones, consultar

RETENCIÓN LUG ASME CLASE 1500¹

Tamaño		A	B	C	Peso (kg)
In.	mm.				
2"	50	216	70	43	17
3"	80	267	83	67	32
4"	100	311	102	87	51
6"	150	394	159	132	119
8"	200	483	206	173	221
10"	250	584	248	216	416
12"	300	673	305	257	646
14"	350	749	356	292	928
16"	400	826	384	325	1179
18"	450	914	468	349	1761
20"	500	984	533	348	2580
24"	600	1168	559	384	3236

RETENCIÓN LUG ASME CLASE 2500¹

Tamaño		A	B	C	Peso (kg)
In.	mm.				
2"	50	235	70	43	22
3"	80	305	86	67	42
4"	100	356	105	87	69
6"	150	483	159	132	175
8"	200	552	206	173	309
10"	250	673	254	216	559
12"	200	762	305	257	853

⁽¹⁾ Otros tamaños y presiones, consultar

VÁLVULAS DE RETENCIÓN NOZZLE

CRANE



High Performance Non-Slam **Check Valves**

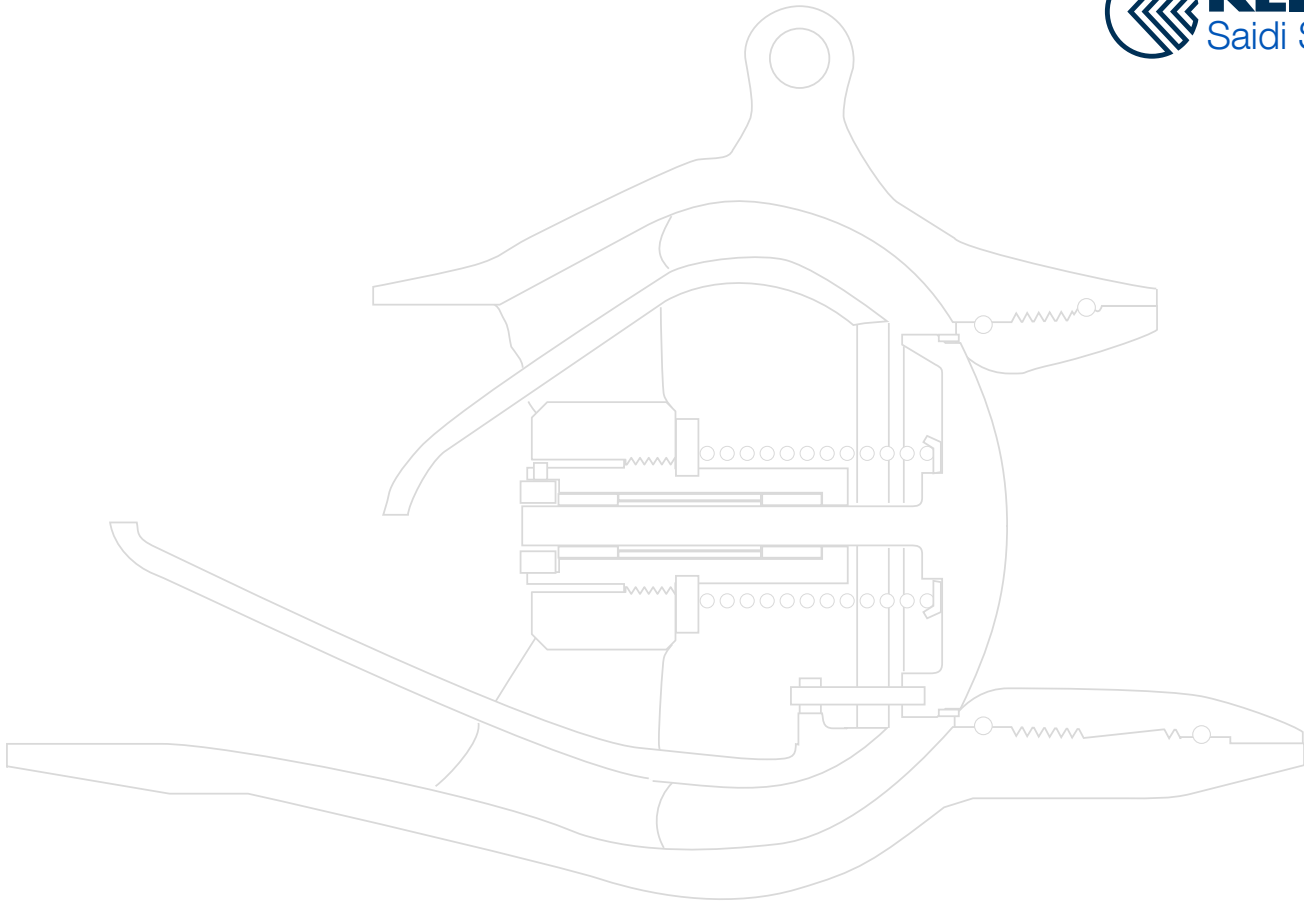

VÁLVULAS RETENCIÓN NOZZLE



APLICACIONES EN LA INDUSTRIA

Gas Transmission

- » Compressor Suction / Discharge / By-pass

Hydrocarbon Processing

- » Catalytic Cracking
- » Hydrotreating

Power Generation

- » Feedwater
- » Cooling water
- » Blowdown
- » Steam

Water Transmission

- » Pipeline
- » Pump Compressor Station

Petrochemical / Chemical Processing

- » Extreme Units
- » Propylene Units



High Performance Non-Slam Check Valves

Gama de productos

- » Tamaño: 2" - 60"
- » ASME B16.34 y API 6D. Presiones 150 a 4500LBS
- » API 6A. Presiones 2000 a 15000 psi
- » Conexiones: Bridas, Butt Weld, Hub y otros extremos especiales
- » Paso estándar (distancia larga) y distancia corta
- » Amplia gama de materiales de construcción disponibles. Consúltenos cualquier especificación de materiales para aplicaciones especiales.

Válvulas de Retención Non-Slam de alto rendimiento

En el diseño de sistemas de tuberías, uno de los puntos más importantes consiste en conjugar la protección de los elementos mecánicos y la prevención de daños causados por el retorno de flujo (backflow). La prevención del retorno de flujo se consigue habitualmente mediante el uso de válvulas de retención a clapeta o válvulas de retención de doble plato.

Las válvulas de retención Nozzle están específicamente diseñadas para sistemas en los que el retorno del flujo es constante. En muchas aplicaciones críticas, las válvulas de retención Non-Slam proporcionan los siguientes beneficios:

- » Minimiza los efectos dañinos provocados por el golpe de ariete
- » Elimina los ruidos que se dan con válvulas convencionales
- » Protege los equipos de bombas rotativas en los que se da el retorno de flujo
- » Reduce la pérdida de carga en los sistemas de tuberías
- » Proporciona una rápida respuesta reduciendo a su vez la velocidad del reflujo

Las válvulas de retención Nozzle están diseñadas y fabricadas siguiendo los más estrictos estándares de Calidad según ISO 9001, Stoomwezen y TÜV.



NORMAS DE LA INDUSTRIA APLICABLES

API 598	Ensayos e Inspecciones de Presión en Válvulas
ASME B16.34	Rango Presión / Temperatura
API 6D	Válvulas para tuberías
API 6A	Válvulas para producción

VÁLVULAS RETENCIÓN NOZZLE

RETENCIÓN NOZZLE TIPO BRIDAS

CRANE® Retención		Tipo: Noz-Chek®
Válvula Retención High Performance Non-Slam		
Especificaciones		
Materiales cuerpo	Acero carbono WCB, Acero inox. CF8M, CA15, Fundición Dúctil EN GJS-450-10, Acero aleado LCC, Duplex...	
Materiales asientos	Buna-N, Viton-B®, Metal, PTFE, EPDM alimentario	
Presiones	ASME Clase 150 a 4500, API 2000 a 15000, DIN, JIS, BS, AS	
Longitud	Estándar (larga) y Corta	
Diseño	API 598, ASME B16.34, API 6D y 6A	
Conexiones	Bridas, Butt Welding, Hub-Ends (otros tipos, bajo demanda)	

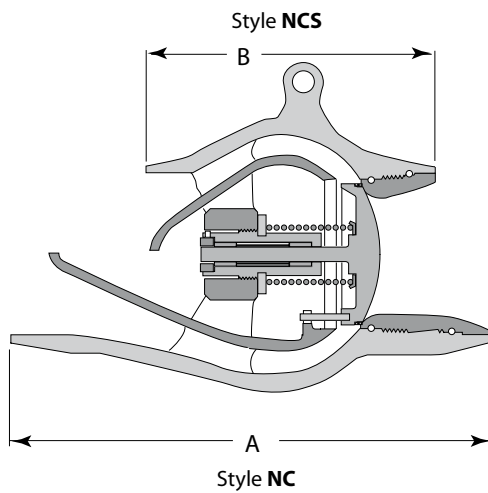

RETENCIÓN NOZZLE 150 RF

Tamaño	Distancia Estándar	Distancia Corta	Peso (kg)	
	A	B	A	B
2"	203	-	10	-
3"	241	-	30	-
4"	292	-	48	-
6"	356	-	76	-
8"	495	-	194	-
10"	622	365	243	220
12"	699	438	285	282
14"	787	475	428	347
16"	864	545	489	415
18"	978	610	814	538
20"	978	850	1441	1075
24"	1295	810	1152	1310
28"	1448	945	2006	1560
30"	1524	1010	2457	1965
36"	1956	1000	2714	2605
42"	-	1415	-	4100
48"	-	1461	-	5275
54"	-	1850	-	9450
60"	-	2035	-	10800

RETENCIÓN NOZZLE 300 RF

Tamaño	Distancia Estándar	Distancia Corta	Peso (kg)	
	A	B	A	B
2"	267	-	13	-
3"	318	-	30	-
4"	356	-	48	-
6"	445	254	95	88
8"	533	311	204	190
10"	622	365	278	248
12"	711	438	331	305
14"	838	475	538	445
16"	864	545	647	530
18"	978	610	820	690
20"	1016	810	1173	1090
24"	1346	810	1514	1370
28"	1499	1035	2387	2200
30"	1524	1010	2645	2394
36"	2083	1000	4358	3670
42"	-	1415	-	5620
48"	-	1461	-	5325
54"	-	1850	-	10140
60"	-	2035	-	11100

RETENCIÓN NOZZLE 600 RF

Tamaño	Distancia Estándar	Distancia Corta	Peso (kg)	
	A	B	A	B
2"	292	-	17	-
3"	356	-	30	-
4"	432	-	74	-
6"	559	390	193	169
8"	660	311	250	203
10"	787	365	399	335
12"	838	438	516	426
14"	889	475	652	538
16"	991	546	957	790
18"	1092	810	1547	1355
20"	1194	810	1537	1380
24"	1397	810	2411	1935
28"	1600	870	3934	2660
30"	1651	1010	3935	3000
36"	2083	1215	8779	4500
42"	-	1461	-	6584
48"	-	1615	-	10250
54"	-	1829	-	12400
60"	-	2159	-	18500

RETENCIÓN NOZZLE 1500 RF

Tamaño				
	A	B	A	B
2"	368	-	36	-
3"	470	-	78	-
4"	546	-	123	-
6"	705	403	365	270
8"	832	346	457	365
10"	991	394	897	628
12"	1130	457	1202	900
14"	1257	648	2237	1600
16"	1384	750	2488	1840
18"	1537	813	3677	2700
20"	1664	869	4176	2950
24"	1943	869	6046	5190

RETENCIÓN NOZZLE 900 RF

Tamaño	Distancia Estándar	Distancia Corta	Peso (kg)	
	A	B	A	B
2"	368	-	36	-
3"	381	-	55	-
4"	457	-	100	-
6"	610	391	257	193
8"	737	346	335	290
10"	838	394	684	483
12"	965	457	885	675
14"	1029	473	1328	695
16"	1130	750	1463	1220
18"	1219	775	2021	1440
20"	1321	869	2941	2120
24"	1549	1016	3686	3182
28"	-	1016	-	4650
30"	-	1026	-	4750
36"	-	1190	-	7250
42"	-	1524	-	9920
48"	-	1626	-	14400

RETENCIÓN NOZZLE 2500 RF

Tamaño	Distancia Estándar	Distancia Corta	Peso (kg)	
	A	B	A	B
2"	451	-	52	-
3"	578	-	119	-
4"	673	-	168	-
6"	914	403	593	485
8"	1022	449	873	700
10"	1270	562	1650	1227
12"	1422	914	2542	2073

VÁLVULAS DE BRONCE Y LATÓN

- » Steam applications
- » Irrigation
- » Petrochemical industry
- » Ship-yard industry
- » Compressed air
- » Textile industry
- » Mechanical industry



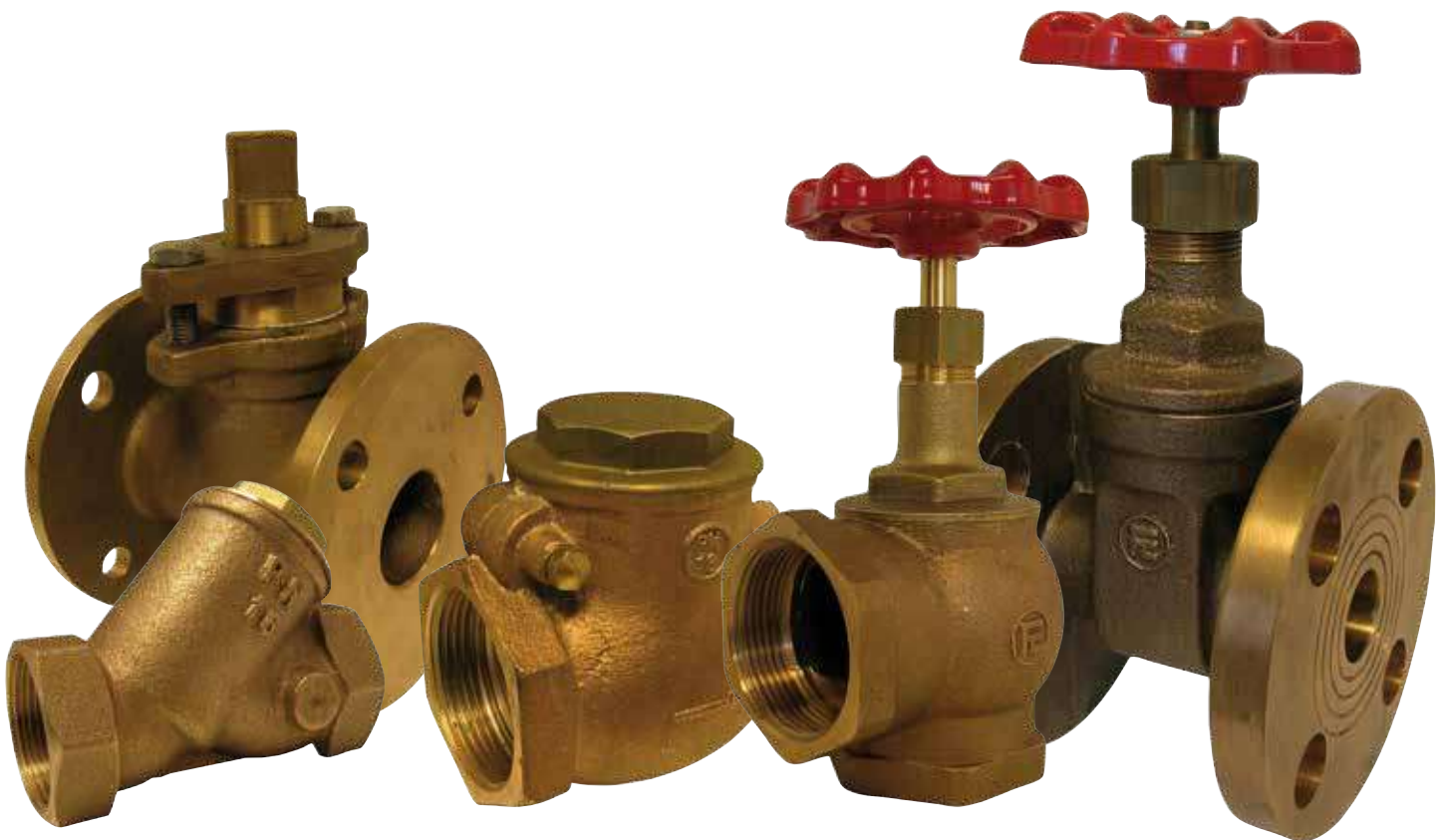

BRONCE Y LATÓN

COMPUERTA BRONCE TIPO ROSCADA

COMPUERTA BRONCE Tipo Roscada Fig. 10250		Tipo: Bronce y Latón
Válvula Compuerta en Bronce Roscada		
Especificaciones		
Cuerpo	Bronce	
Tapa y Cuña	Latón	
Husillo y Prensa	Latón	
Asiento	Integral	
Rating	DIN PN20/B 125 WSP, 250 WOG	
Conexiones	ISO 7, ISO 228 y NPT	

» Otros modelos y materiales, consultar



Componentes		
Pos.	Denominación	Material
1	Cuerpo	Bronce CC491K UNI EN 1982
2	Cuña	Latón CW617N UNI EN 12165
3	Husillo	Latón CW614N UNI EN 12164
4	Anillo husillo	Latón CW614N UNI EN 12164
5	Tapa	Latón CW617N UNI EN 12165
6	Empaquetadura	PTFE (hasta 1") y AF/15/MA (> 1")
7	Casquillo prensaestopas	Latón CW614N UNI EN 12164
8	Tuerca prensaestopas	Latón CW614N UNI EN 12164
9	Volante	Aluminio GD12FE UNI EN 1706
10	Tuerca volante	Acero 6S UNI 5589

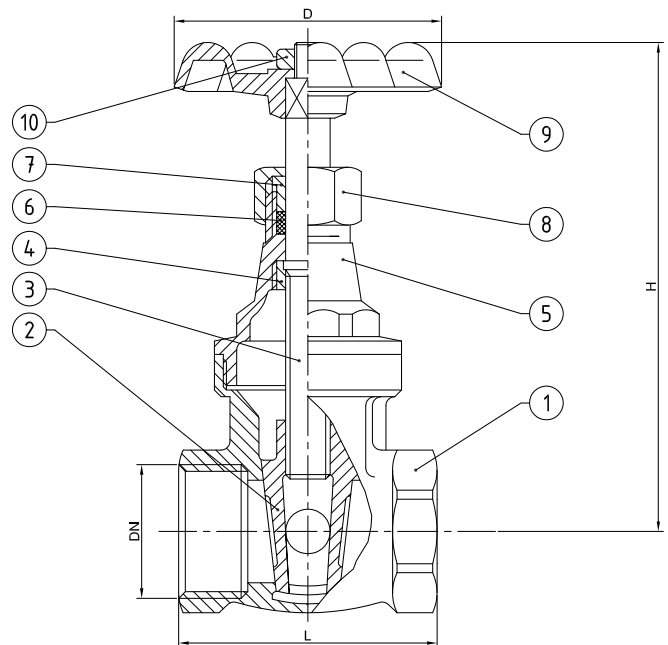

FIG. 10250 - COMPUERTA BRONCE ROSCADA

Código	Tamaño	D	L	H	Peso (kg.)
-	1/4"	50	45	70	0,260
-	3/8"	50	45	70	0,270
-	1/2"	50	49	70	0,282
-	3/4"	55	51	86	0,377
-	1"	60	57	98	0,542
-	1.1/4"	70	68	120	0,896
-	1.1/2"	80	70	137	1,210
-	2"	95	82	160	1,900
-	2.1/2"	110	96	189	2,850
-	3"	130	107	240	4,850
-	4"	130	122	265	7,800

COMPUERTA BRONCE TIPO ROSCADA



COMPUERTA BRONCE Tipo Roscada Fig. 12101		Tipo: Bronce y Latón
Válvula Compuerta en Bronce Roscada		
Especificaciones		
Cuerpo	Bronce	
Tapa	Latón	
Husillo y Obturador	Latón	
Asiento	Integral	
Rating	DIN PN25/B, 150 WSP, 300 WOG	
Conexiones	ISO 7, ISO 228 y NPT	

» Otros modelos y materiales, consultar

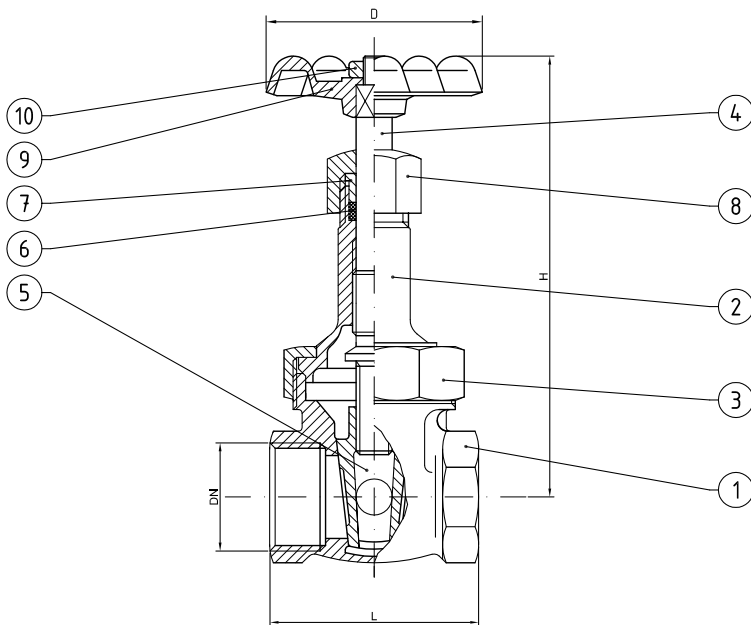

Componentes		
Pos.	Denominación	Material
1	Cuerpo	Bronce C83600 ASTM B62
2	Tapa	Latón CW617N UNI EN 12165 (hasta 2.1/2") y Bronce C83600 ASTM B62 (3" y 4")
3	Union Bonnet	Latón CW617N UNI EN 12165 (hasta 3") y Bronce C83600 ASTM B62 (4")
4	Husillo	Latón CW614N UNI EN 12164
5	Cuña	Latón CW617N UNI EN 12165
6	Empaquetadura	AF/15/MA
7	Prensaestopas	Latón CW614N UNI EN 12164
8	Tuerca prensaestopas	Latón CW614N UNI EN 12164
9	Volante	Aluminio GD12FE UNI EN 1706
10	Tuerca volante	Acero 6S UNI 5589

FIG. 12101 - GLOBO BRONCE ROSCADA

Código	Tamaño	D	L	H	Peso (kg.)
-	1/4"	50	41	94	0,290
-	3/8"	50	41	105	0,350
-	1/2"	55	51	120	0,500
-	3/4"	60	58	135	0,700
-	1"	70	64	150	0,950
-	1.1/4"	80	70	170	1,300
-	1.1/2"	80	75	190	1,700
-	2"	95	85	225	2,600
-	2.1/2"	110	98	300	4,500
-	3"	130	105	340	5,750
-	4"	150	120	420	9,400

BRONCE Y LATÓN

COMPUERTA BRONCE TIPO ROSCADA

COMPUERTA BRONCE Tipo Roscada Fig. 12108		Tipo: Bronce y Latón
Válvula Compuerta en Bronce Roscada		
Especificaciones		
Cuerpo y Tapa	Bronce	
Obturador	Bronce	
Husillo	Latón	
Asiento	Integral	
Rating	DIN PN32/B, 200 WSP, 400 WOG	
Conexiones	ISO 7, ISO 228 y NPT	

» Otros modelos y materiales, consultar

Componentes		
Pos.	Denominación	Material
1	Cuerpo	Bronce CC491K UNI EN 1982
2	Obturador	Bronce CC491K UNI EN 1982
3	Husillo	Latón CW614N UNI EN 12164
4	Tapa	Bronce CC491K UNI EN 1982
5	Union Bonnet	Bronce CC491K UNI EN 1982
6	Empaquetadura	AF/15/MA
7	Casquillo prensaestopas	Latón CW614N UNI EN 12164
8	Tuerca prensaestopas	Latón CW614N UNI EN 12164 (hasta 2") y Bronce CC491K UNI EN 1982 (> 2")
9	Volante	Aluminio GD12FE UNI EN 1706
10	Tuerca volante	Acero S6 UNI 5589

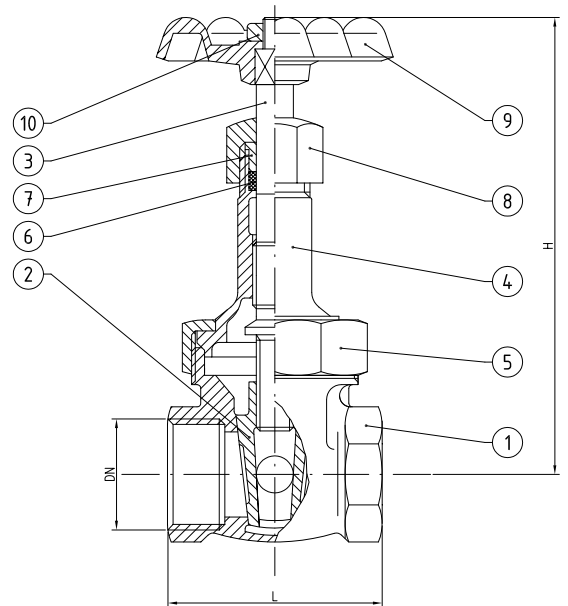

FIG. 12108 - COMPUERTA BRONCE ROSCADA

Código	Tamaño	L	H	Peso (kg.)
-	1/4"	50	110	0,550
-	3/8"	50	110	0,550
-	1/2"	55	120	0,800
-	3/4"	64	140	1,200
-	1"	70	155	1,700
-	1.1/4"	75	190	2,350
-	1.1/2"	90	210	3,100
-	2"	95	230	4,000
-	2.1/2"	110	265	5,700
-	3"	115	285	7,500
-	3.1/2"	125	380	12,850
-	4"	125	380	12,200

COMPUERTA BRONCE TIPO ROSCADA



COMPUERTA BRONCE Tipo Roscada Fig. 13103		Tipo: Bronce y Latón
Válvula Compuerta en Bronce Roscada		
Especificaciones		
Cuerpo	Bronce	
Tapa	Bronce	
Obturador	Bronce	
Asiento	Integral	
Rating	DIN PN64, 300 WSP, 1000 WOG	
Conexiones	ISO 7, ISO 228 y NPT	

» Otros modelos y materiales, consultar

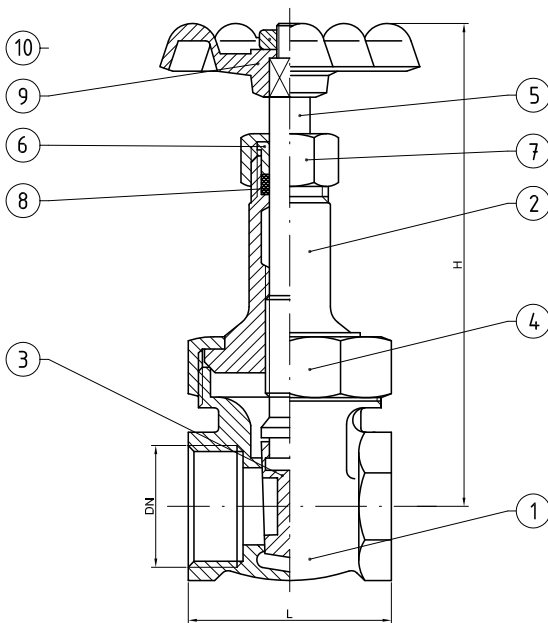

Componentes		
Pos.	Denominación	Material
1	Cuerpo	Bronce CC491K EN 1982
2	Tapa	Bronce CC491K EN 1982
3	Cuña	Bronce CC491K EN 1982
4	Union Bonnet	Bronce CC491K EN 1982
5	Husillo	Latón CW614N UNI EN 12164
6	Casquillo prensaestopas	Latón CW614N UNI EN 12164
7	Tuerca prensaestopas	Latón CW614N UNI EN 12164
8	Empaquetadura	AF/15/MA
9	Volante	Aluminio GD12FE UNI EN 1706
10	Tuerca volante	Acero

FIG. 13103 - COMPUERTA BRONCE ROSCADA

Código	Tamaño	L	H	Peso (kg.)
-	1/4"	55	125	0,850
-	3/8"	60	130	0,900
-	1/2"	65	145	1,300
-	3/4"	70	165	1,800
-	1"	75	180	2,400
-	1.1/4"	80	225	3,000
-	1.1/2"	95	220	3,700
-	2"	110	260	5,700
-	3"	115	285	7,500

BRONCE Y LATÓN

COMPUERTA BRONCE TIPO BRIDAS

COMPUERTA BRONCE Tipo Bridas Fig. 15250		Tipo: Bronce y Latón
Válvula Compuerta en Bronce con Bridas		
Especificaciones		
Cuerpo	Bronce	
Tapa	Latón	
Obturador y Husillo	Latón	
Asiento	Integral	
Rating	DIN PN16/B, 100 WSP, 200 WOG	
Conexiones	Bridas DIN PN16	

» Otros modelos y materiales, consultar

Componentes		
Pos.	Denominación	Material
1	Cuerpo	Bronce CC491K UNI EN 1982
2	Obturador	Latón CW617N UNI EN 12165
3	Husillo	Latón CW614N UNI EN 12164
4	Anillo husillo	Latón CW614N UNI EN 12164
5	Tapa	Latón CW617N UNI EN 12165
6	Empaquetadura	PTFE (1/4" a 1") y AF/15/MA (1.1/4" a 4")
7	Casquillo prensaestopas	Latón CW614N UNI EN 12164
8	Tuerca prensaestopas	Latón CW614N UNI EN 12164
9	Volante	Aluminio GD12FE UNI EN 1706
10	Tuerca volante	Acero S6 UNI 5589

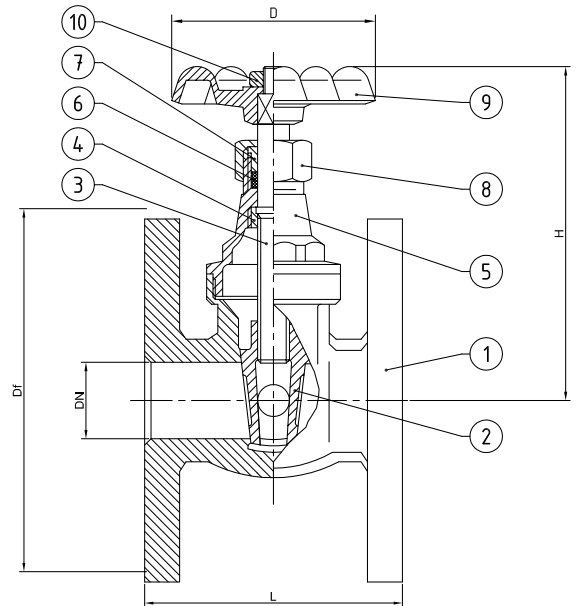

FIG. 15250 - COMPUERTA BRONCE CON BRIDAS

Código	Tamaño	Df	D	L	H	Peso (kg.)
-	3/8"	90	50	75	70	1,500
-	1/2"	95	50	75	70	1,500
-	3/4"	105	55	75	86	1,800
-	1"	115	60	80	98	2,180
-	1.1/4"	140	70	92	120	3,430
-	1.1/2"	150	80	99	137	4,500
-	2"	165	95	112	160	5,570
-	2.1/2"	185	110	130	189	8,800
-	3"	200	130	147	240	10,300
-	4"	220	150	164	265	15,300

COMPUERTA BRONCE TIPO BRIDAS



COMPUERTA BRONCE Tipo Bridas Fig. 15603		Tipo: Bronce y Latón
Válvula Compuerta en Bronce con Bridas		
Especificaciones		
Cuerpo	Bronce	
Tapa	Bronce	
Obturador	Bronce	
Asiento	Integral	
Rating	DIN PN25/B, 150 WSP, 300 WOG	
Conexiones	Bridas DIN PN25	

» Otros modelos y materiales, consultar

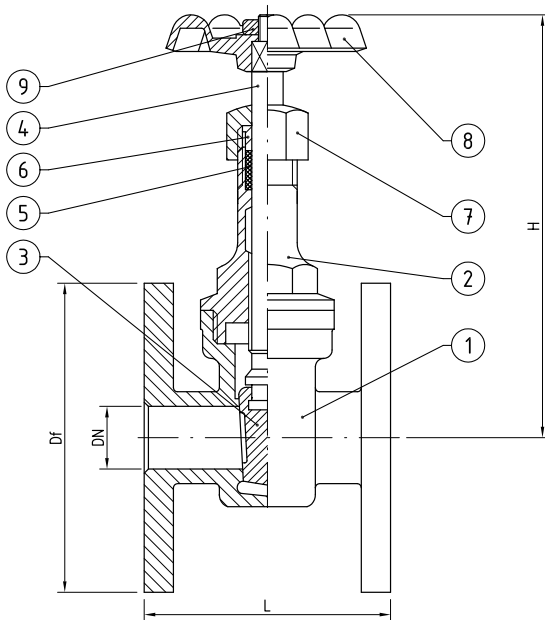

Componentes		
Pos.	Denominación	Material
1	Cuerpo	Bronce CC491K EN 1982
2	Tapa	Bronce CC491K EN 1982
3	Cuña	Bronce CC491K EN 1982
4	Husillo	Latón CW614N UNI EN 12164
5	Empaquetadura	AF/15/MA
6	Casquillo prensaestopas	Latón CW614N UNI EN 12164
7	Tuerca prensaestopas	Latón CW614N UNI EN 12164 (1/2" a 2.1/2") y Bronce CC491K UNI EN 1982 (3" y 4")
8	Volante	Aluminio GD12FE UNI EN 1706
9	Tuerca volante	Acero 6S UNI 5589

FIG. 15603 - COMPUERTA BRONCE CON BRIDAS

Código	Tamaño	L	H	D	Df	Peso (kg.)
-	15	80	100	55	95	1,700
-	20	85	120	60	105	2,200
-	25	90	135	70	115	3,100
-	32	105	150	80	140	4,800
-	40	115	175	80	150	5,700
-	50	125	195	95	165	7,400
-	65	145	230	95	185	10,700
-	80	160	260	95	200	13,500
-	100	170	290	95	220	19,000

BRONCE Y LATÓN

COMPUERTA BRONCE TIPO BRIDAS

COMPUERTA BRONCE Tipo Bridas Fig. 16706		Tipo: Bronce y Latón
Válvula Compuerta en Bronce con Bridas		
Especificaciones		
Cuerpo	Bronce	
Tapa	Bronce	
Obturador	Bronce	
Asiento	Integral	
Rating	DIN PN40/B, 250 WSP, 500 WOG	
Conexiones	Bridas DIN PN40	

» Otros modelos y materiales, consultar

Componentes		
Pos.	Denominación	Material
1	Cuerpo	Bronce CC491K UNI EN 1982
2	Tapa	Bronce CC491K UNI EN 1982
3	Obturador	Bronce CC491K UNI EN 1982
4	Husillo	Latón CW614N UNI EN 12164
5	Anillo husillo	Latón CW614N UNI EN 12164
6	Empaquetadura	AF/15/MA
7	Casquillo prensaestopas	Latón CW614N UNI EN 12164
8	Tuerca prensaestopas	Latón CW614N UNI EN 12164
9	Volante	Aluminio GD12FE UNI EN 1706
10	Tuerca volante	Acero S6 UNI 5589

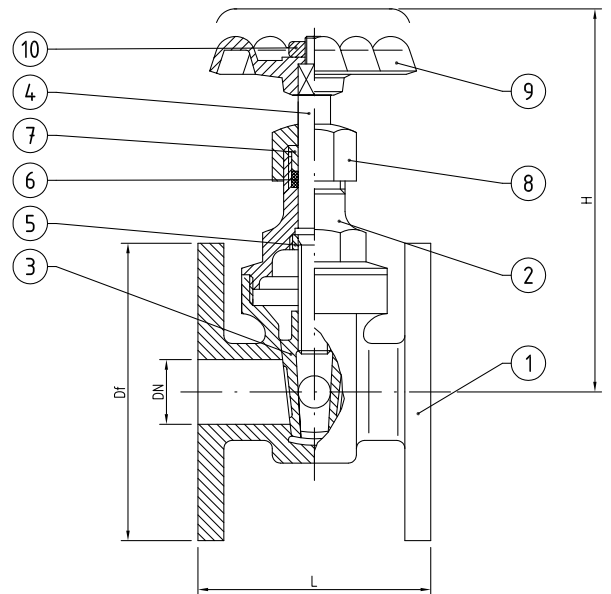
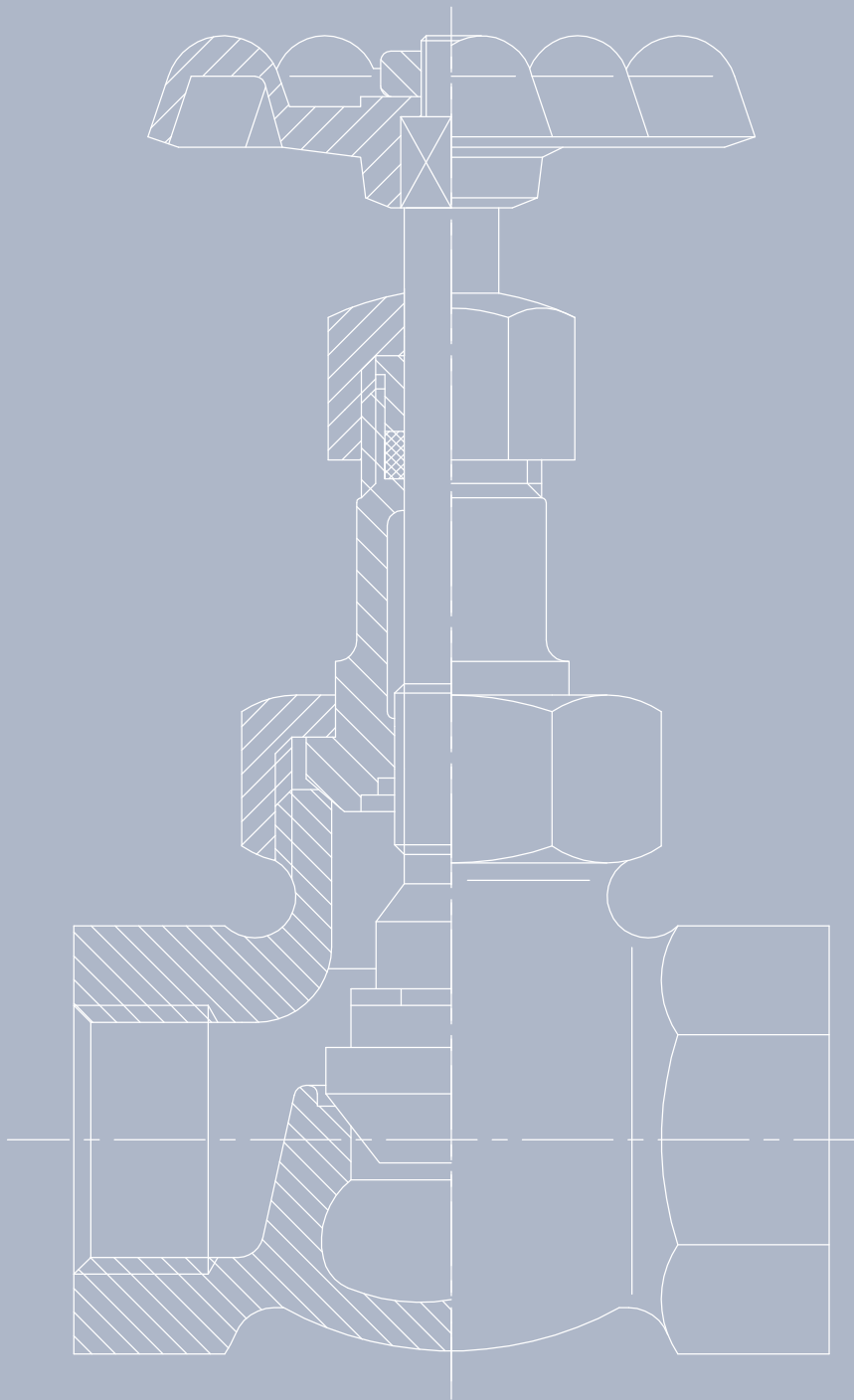

FIG. 16706 - COMPUERTA BRONCE CON BRIDAS

Código	Tamaño	Df	L	H	Peso (kg.)
-	15	95	85	115	2,400
-	20	105	90	120	3,300
-	25	115	100	145	4,000
-	32	140	115	165	5,800
-	40	150	125	180	8,300
-	50	165	140	205	10,200



GLOBEVALVES

BRONCE Y LATÓN

GLOBO BRONCE TIPO ROSCADA

GLOBO BRONCE Tipo Roscada Fig. 70402		Tipo: Bronce y Latón
Válvula Globo en Bronce Roscada		
Especificaciones		
Cuerpo	Bronce	
Tapa	Latón	
Obturador	PTFE	
Husillo	Latón	
Rating	DIN PN16/B, 100 WSP, 200 WOG	
Conexiones	ISO 7, ISO 228 y NPT	

» Otros modelos y materiales, consultar



Componentes		
Pos.	Denominación	Material
1	Cuerpo	Bronce C83600 ASTM B62
2	Tapa	Latón CW617N UNI EN 12165
3	Husillo	Latón CW614N UNI EN 12164
4	Casquillo prensaestopas	Latón CW614N UNI EN 12164
5	Tuerca prensaestopas	Latón CW614N UNI EN 12164
6	Empaquetadura	PTFE
7	Anillo disco	Latón CW614N UNI EN 12164
8	Placa disco	Latón CW614N UNI EN 12164
9	Disco	PTFE
10	Tuerca disco	Latón CW614N UNI EN 12164
11	Volante	Aluminio GD12FE UNI EN 1706
12	Tuerca volante	Acero S6 UNI 5589
13	Junta	Fibra (sólo para 1/4" a 1")

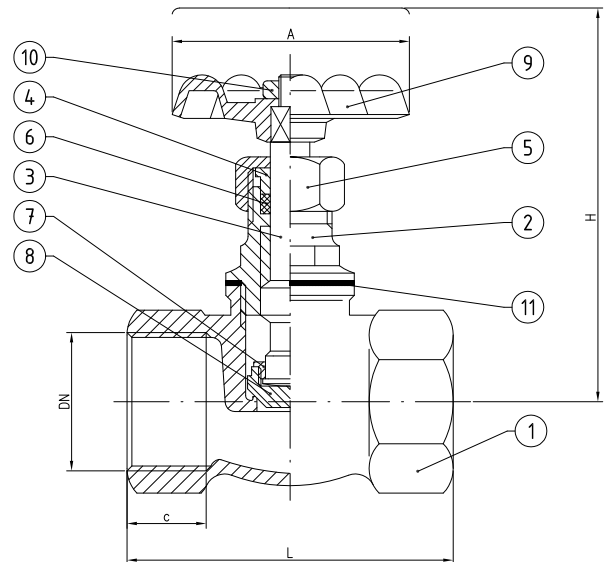

FIG. 70402 - GLOBO BRONCE ROSCADA

Código	Tamaño	L	C	H	A	Peso (kg.)
-	1/4"	45	9.5	66	50	0,200
-	3/8"	45	9.5	66	50	0,200
-	1/2"	49	11	67	50	0,210
-	3/4"	55	13	78	50	0,320
-	1"	63	12	90	55	0,460
-	1.1/4"	72	15	100	60	0,680
-	1.1/2"	89	15	125	70	1,030
-	2"	100	19	145	80	1,450

GLOBO BRONCE TIPO ROSCADA



GLOBO BRONCE Tipo Roscada Fig. 75221		Tipo: Bronce y Latón
Válvula Globo en Bronce Roscada		
Especificaciones		
Cuerpo	Bronce	
Tapa	Latón	
Obturador	Latón	
Asiento	Integral	
Rating	DIN PN25/B, 150 WSP, 300 WOG	
Conexiones	ISO 7, ISO 228 y NPT	

» Otros modelos y materiales, consultar

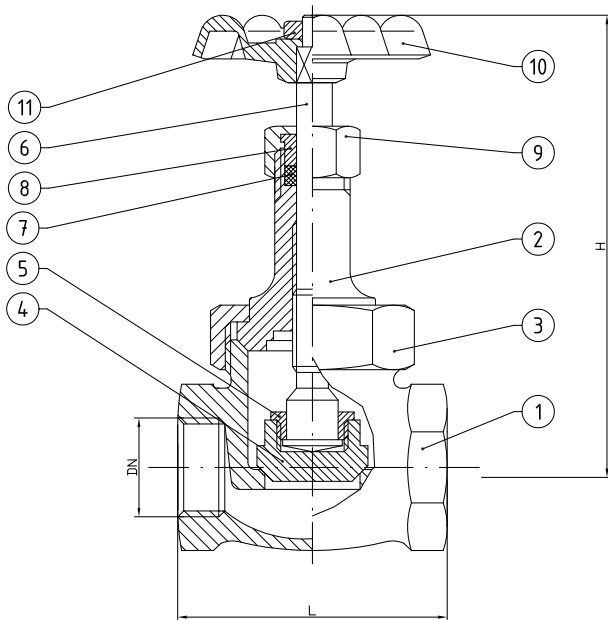

Componentes		
Pos.	Denominación	Material
1	Cuerpo	Bronce C83600 ASTM B62
2	Tapa	Latón CW617N UNI EN 12165 (1/4" a 2.1/2") y Bronce C83600 ASTM B62 (3" y 4")
3	Union Bonnet	Latón CW617N UNI EN 12165 (1/4" a 3") y Bronce C83600 ASTM B62 (4")
4	Obturador	Latón CW614N UNI EN 12164 (1/4" a 2") y Bronce C83600 ASTM B62 (2.1/2" a 4")
5	Anillo obturador	Latón CW614N UNI EN 12164
6	Husillo	Latón CW614N UNI EN 12164
7	Empaquetadura	AF/15/MA
8	Casquillo prensaestopas	Latón CW614N UNI EN 12164
9	Tuerca prensaestopas	Latón CW614N UNI EN 12164 (1/4" a 2.1/2") y Bronce C83600 ASTM B62 (3" y 4")
10	Volante	Aluminio GD12Fe UNI EN 1706
11	Tuerca volante	Acero S6 UNI 5589

FIG. 75221 - GLOBO BRONCE ROSCADA

Código	Tamaño	L	H	Peso (kg.)
-	1/4"	46	100	0,300
-	3/8"	46	100	0,300
-	1/2"	56	105	0,355
-	3/4"	62	135	0,680
-	1"	74	150	1,000
-	1.1/4"	91	170	1,480
-	1.1/2"	100	195	1,850
-	2"	128	220	2,850
-	2.1/2"	145	230	4,500
-	3"	170	250	7,300
-	4"	210	370	13,350

BRONCE Y LATÓN

GLOBO BRONCE TIPO ROSCADA

GLOBO BRONCE Tipo Roscada Fig. 72451		Tipo: Bronce y Latón
Válvula Globo en Bronce Roscada		
Especificaciones		
Cuerpo	Bronce	
Tapa	Latón	
Obturador	Latón	
Asiento	Integral	
Rating	DIN PN25/B, 150 WSP, 300 WOG	
Conexiones	ISO 7, ISO 228 y NPT	

» Otros modelos y materiales, consultar

Componentes		
Pos.	Denominación	Material
1	Cuerpo	Bronce CC491K UNI EN 1982
2	Tapa	Latón CW617N UNI EN 12165 (1/4" a 2") y Bronce CC491K UNI EN 1982 (2.1/2" a 4")
3	Obturador	Latón CW614N UNI EN 12164 (1/4" a 2") y Bronce CC491K UNI EN 1982 (2.1/2" a 4")
4	Anillo obturador	Latón CW614N UNI EN 12164
5	Husillo	Latón CW614N UNI EN 12164
6	Empaquetadura	PTFE (1/4" a 1/2") y AF/15/MA (3/4" a 4")
7	Casquillo prensaestopas	Latón CW614N UNI EN 12164
8	Tuerca prensaestopas	Latón CW617N UNI EN 12165 (1/4" a 3") y Bronce CC491K UNI EN 1982 (4")
9	Volante	Aluminio GD12Fe UNI EN 1706
10	Tuerca volante	Acero 6S UNI 5589

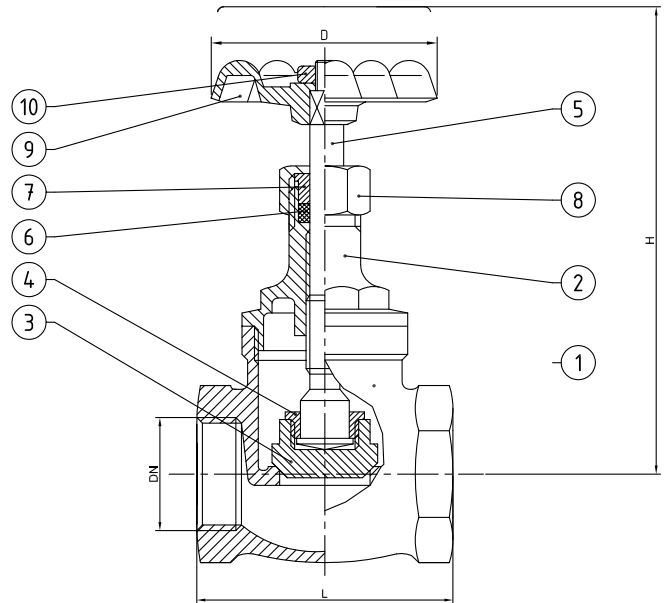

FIG. 72451 - GLOBO BRONCE ROSCADA

Código	Tamaño	L	H	Peso (kg.)
-	1/4"	46	80	0,220
-	3/8"	46	80	0,220
-	1/2"	55	85	0,320
-	3/4"	62	115	0,550
-	1"	74	125	0,800
-	1.1/4"	90	155	1,300
-	1.1/2"	100	165	1,500
-	2"	128	185	2,500
-	2.1/2"	145	235	4,300
-	3"	170	250	6,500
-	4"	210	330	12,000

GLOBO BRONCE TIPO ROSCADA



GLOBO BRONCE Tipo Roscada Fig. 72452		Tipo: Bronce y Latón
Válvula Globo en Bronce Roscada		
Especificaciones		
Cuerpo	Bronce	
Tapa	Latón	
Obturador	PTFE	
Husillo	Latón	
Rating	DIN PN25/B, 150 WSP, 300 WOG	
Conexiones	ISO 7, ISO 228 y NPT	

» Otros modelos y materiales, consultar

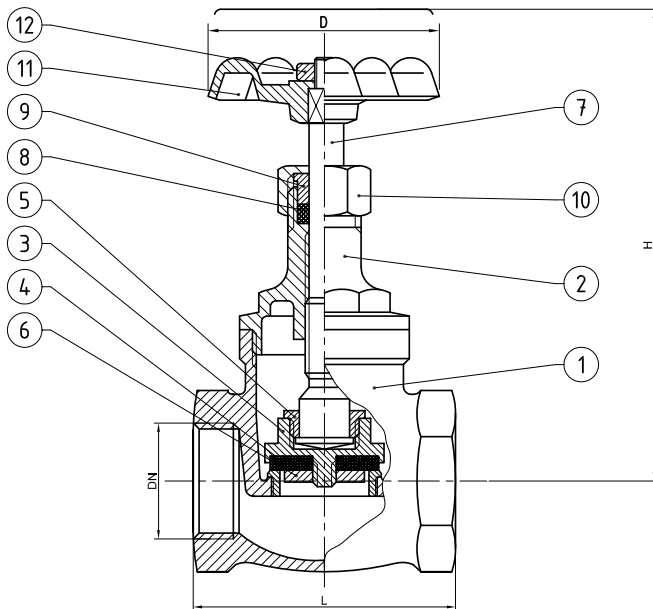

Componentes		
Pos.	Denominación	Material
1	Cuerpo	Bronce C83600 ASTM B62
2	Tapa	Latón CW617N UNI EN 12165 (1/4" a 2") y Bronce C83600 ASTM B62 (2.1/2" y 4")
3	Soporte obturador	Latón CW617N UNI EN 12165 (1/4" a 2.1/2") y Bronce C83600 ASTM B62 (3" y 4")
4	Obturador	PTFE
5	Anillo obturador	Latón CW614N UNI EN 12164
6	Tuerca obturador	Latón CW614N UNI EN 12164
7	Husillo	Latón CW614N UNI EN 12164
8	Empaquetadura	PTFE (1/4" a 1/2") y AF/15/MA (3/4" a 4")
9	Casquillo prensaestopas	Latón CW614N UNI EN 12164
10	Tuerca prensaestopas	Latón CW617N UNI EN 12165 (1/4" a 3") y Bronce C83600 ASTM B62 (4")
11	Volante	Aluminio GD12Fe UNI EN 1706
12	Tuerca volante	Acero S6 UNI 5589

FIG. 72452 - GLOBO BRONCE ROSCADA

Código	Tamaño	L	H	Peso (kg.)
-	1/4"	46	80	0,220
-	3/8"	46	80	0,220
-	1/2"	55	85	0,320
-	3/4"	62	115	0,550
-	1"	74	125	0,800
-	1.1/4"	90	155	1,300
-	1.1/2"	100	165	1,500
-	2"	128	185	2,500
-	2.1/2"	145	235	4,300
-	3"	170	250	6,500
-	4"	210	330	12,000

BRONCE Y LATÓN

GLOBO BRONCE TIPO BRIDAS

GLOBO BRONCE Tipo Bidas Fig. 80401		Tipo: Bronce y Latón
Válvula Globo en Bronce con Bidas		
Especificaciones		
Cuerpo	Bronce	
Tapa	Latón	
Obturador y Husillo	Latón	
Asiento	Integral	
Rating	DIN PN16/B, 100 WSP, 200 WOG	
Conexiones	Bidas DIN PN16	

» Otros modelos y materiales, consultar



Componentes		
Pos.	Denominación	Material
1	Cuerpo	Bronce CC491K UNI EN 1982
2	Tapa	Latón CW617N UNI EN 12165 (1/4" a 2") y Bronce CC491K UNI EN 1982 (2.1/2" a 4")
3	Obturador	Latón CW614N UNI EN 12164 (1/4" a 2") y Bronce CC491K UNI EN 1982 (2.1/2" a 4")
4	Anillo obturador	Latón CW614N UNI EN 12164
5	Husillo	Latón CW614N UNI EN 12164
6	Empaquetadura	PTFE (1/4" a 1/2") y AF/15/MA (3/4" a 4")
7	Casquillo prensaestopas	Latón CW614N UNI EN 12164
8	Tuerca prensaestopas	Latón CW617N UNI EN 12165 (1/4" a 3") y Bronce CC491K UNI EN 1982 (4")
9	Volante	Aluminio GD12Fe UNI EN 1706
10	Tuerca volante	Acero 6S UNI 5589

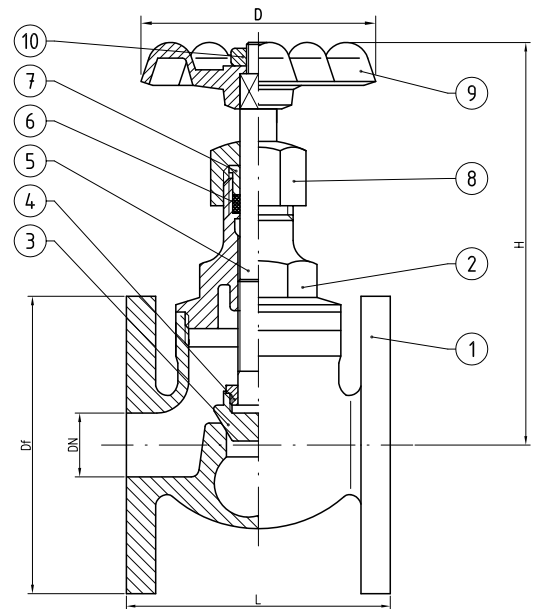

FIG. 80401 - GLOBO BRONCE CON BRIDAS

Código	Tamaño	D	Df	L	H	Peso (kg.)
-	1/2"	55	95	80	125	1,850
-	3/4"	60	105	80	125	1,900
-	1"	70	115	92	130	2,400
-	1.1/4"	80	140	102	160	2,950
-	1.1/2"	80	150	118	190	3,600
-	2"	95	165	140	215	6,300
-	2.1/2"	110	185	160	230	8,700
-	3"	130	200	190	250	11,800
-	4"	150	220	244	300	19,500

GLOBO BRONCE TIPO BRIDAS



GLOBO BRONCE Tipo Bidas Fig. 82001		Tipo: Bronce y Latón
Válvula Globo en Bronce con Bidas		
Especificaciones		
Cuerpo	Bronce	
Tapa	Latón	
Obturador	Latón	
Asiento	Integral	
Rating	DIN PN20/B, 125 WSP, 250 WOG	
Conexiones	Bidas	

» Otros modelos y materiales, consultar

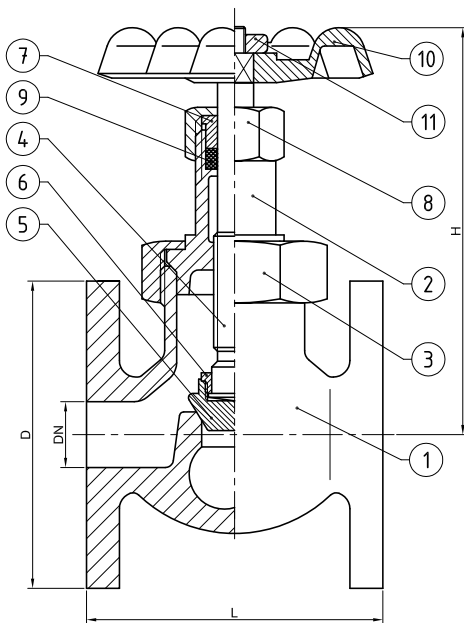

Componentes		
Pos.	Denominación	Material
1	Cuerpo	Bronce CC491K UNI EN 1982
2	Tapa	Latón CW617N UNI EN 12165 (1/4" a 2") y Bronce CC491K UNI EN 1982 (2.1/2" a 4")
3	Tuerca unión	Latón CW617N UNI EN 12165 (1/2" a 2") y Bronce CC491K UNI EN 1982 (2.1/2" a 4")
4	Husillo	Latón CW614N UNI EN 12164
5	Obturador	Latón CW617N UNI EN 12165 (1/2" a 2") y Bronce CC491K UNI EN 1982 (2.1/2" a 4")
6	Anillo obturador	Latón CW614N UNI EN 12164
7	Casquillo prensaestopas	Latón CW614N UNI EN 12164
8	Tuerca prensaestopas	Latón CW617N UNI EN 12165 (1/2" a 2") y Bronce CC491K UNI EN 1982 (2.1/2" a 4")
9	Empaquetadura	AF/15/MA
10	Volante	Aluminio GD12Fe UNI EN 1706
11	Tuerca volante	Acero S6 UNI 5589

FIG. 82001 - GLOBO BRONCE CON BRIDAS

Código	Tamaño	Df	L	H	Peso (kg.)
-	15	95	80	130	1,900
-	20	105	80	135	2,000
-	25	115	92	150	2,500
-	32	140	102	170	3,100
-	40	150	118	195	3,780
-	50	165	140	220	6,600
-	65	185	160	230	9,100
-	80	200	189	250	12,500
-	100	220	244	370	23,200

BRONCE Y LATÓN

RETENCIÓN BRONCE TIPO ROSCADA

RETENCIÓN BRONCE Tipo Roscada Fig. 70651		Tipo: Bronce y Latón
Válvula Retención en Bronce Roscada		
Especificaciones		
Cuerpo	Bronce	
Tapa	Latón	
Obturador	Latón	
Asiento	Integral	
Rating	DIN PN25/B, 150 WSP, 300 WOG	
Conexiones	ISO 7, ISO 228 y NPT	

» Otros modelos y materiales, consultar



Componentes		
Pos.	Denominación	Material
1	Cuerpo	Bronce CC491K UNI EN 1982
2	Tapa	Latón CW614N UNI EN 12164 (1/4" a 1.1/2") Bronce CC491K UNI EN 1982 (2" a 4")
3	Obturador	Latón CW614N UNI EN 12164 (1/4" a 1") Bronce CC491K UNI EN 1982 (1.1/4" a 4")

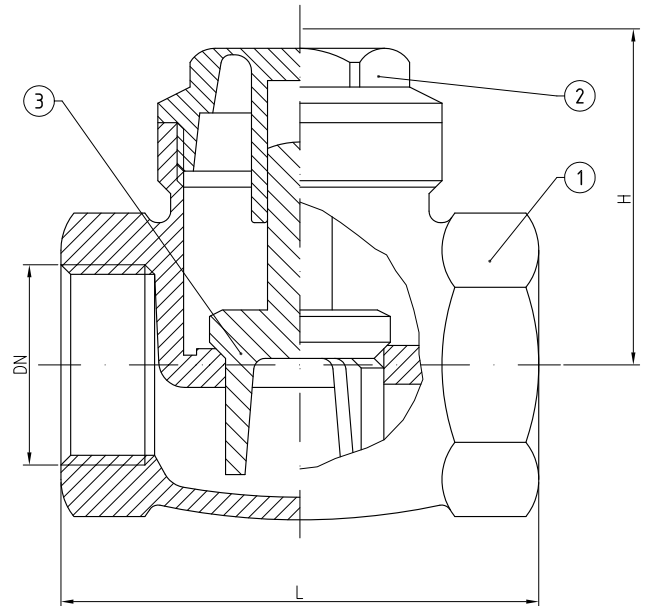

FIG. 70651 - RETENCIÓN BRONCE ROSCADA

Código	Tamaño	L	H	Peso (kg.)
-	1/4"	46	30	0,190
-	3/8"	46	30	0,190
-	1/2"	55	35	0,280
-	3/4"	62	40	0,464
-	1"	74	45	0,700
-	1.1/4"	90	60	1,160
-	1.1/2"	100	60	1,400
-	2"	128	70	2,510
-	2.1/2"	145	90	3,400
-	3"	170	100	5,500
-	4"	210	110	10,800

RETENCIÓN BRONCE TIPO ROSCADA



RETENCIÓN BRONCE Tipo Roscada Fig. 77001		Tipo: Bronce y Latón
Válvula Retención en Bronce Roscada		
Especificaciones		
Cuerpo	Bronce	
Tapa	Bronce	
Clapeta	Latón	
Asiento	Integral	
Rating	DIN PN25/B, 150 WSP, 300 WOG	
Conexiones	ISO 7, ISO 228 y NPT	

» Otros modelos y materiales, consultar

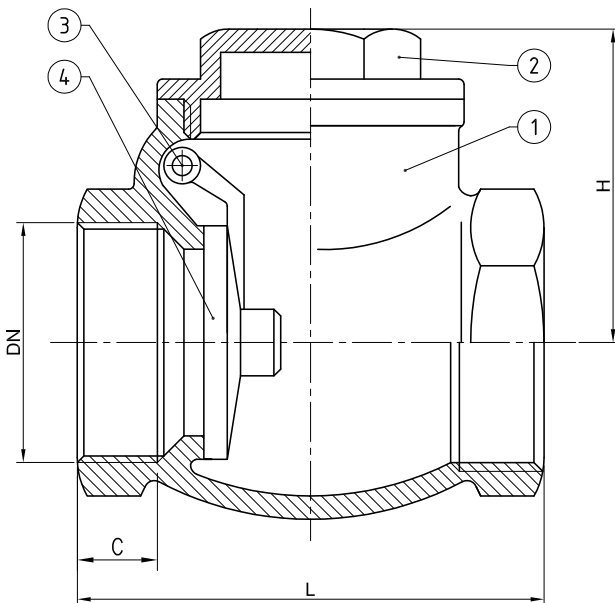

Componentes		
Pos.	Denominación	Material
1	Cuerpo	Bronce C83600 ASTM B62
2	Tapa	Bronce C83600 ASTM B62
3	Bulón	Bronce C83600 ASTM B62
4	Clapeta	Latón CW614N UNI EN 12164 (1/2" a 1.1/4") y Bronce C83600 ASTM B62 (1.1/2" a 4")

FIG. 77001 - RETENCIÓN BRONCE ROSCADA

Código	Tamaño	L	H	Peso (kg.)
-	3/8"	60	40	0,270
-	1/2"	60	45	0,300
-	3/4"	70	50	0,500
-	1"	85	60	0,850
-	1.1/4"	95	70	1,150
-	1.1/2"	110	75	1,700
-	2"	130	85	2,470
-	2.1/2"	150	100	3,750
-	3"	180	120	6,080
-	4"	195	120	9,250

BRONCE Y LATÓN

RETENCIÓN BRONCE TIPO ROSCADA

RETENCIÓN BRONCE Tipo Roscada Fig. 77105		Tipo: Bronce y Latón
Válvula Retención en Bronce Roscada		
Especificaciones		
Cuerpo	Bronce	
Tapa	Latón	
Clapeta	Latón	
Asiento	Integral	
Rating	DIN PN16/B, 100 WSP, 200 WOG	
Conexiones	ISO 7, ISO 228 y NPT	

» Otros modelos y materiales, consultar



Componentes		
Pos.	Denominación	Material
1	Cuerpo	Bronce C83600 ASTM B62
2	Tapa	Latón CW617N UNI EN 12165
3	Bulón	Latón CW614N UNI EN 12164
4	Clapeta	Latón CW617N UNI EN 12165

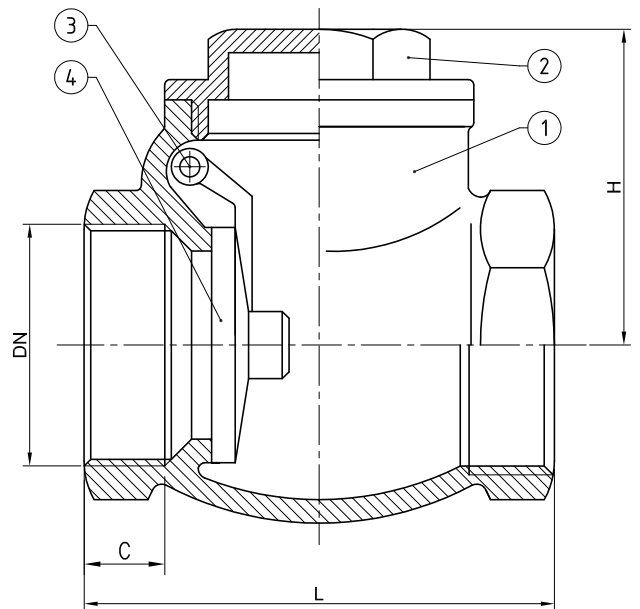

FIG. 77105 - RETENCIÓN BRONCE ROSCADA

Código	Tamaño	L	H	C	Peso (kg.)
-	3/8"	48	32	9	0,167
-	1/2"	52	38	10	0,223
-	3/4"	66.5	45	12	0,365
-	1"	71	48.5	48.5	0,495
-	1.1/4"	90	58	58	0,726
-	1.1/2"	87	62	62	0,832
-	2"	110	67	67	1,380
-	2.1/2"	124	78	67	2,280
-	3"	146	89	67	3,160

RETENCIÓN BRONCE TIPO ROSCADA



RETENCIÓN BRONCE Tipo Roscada Fig. 77204		Tipo: Bronce y Latón
Válvula Retención en Bronce Roscada		
Especificaciones		
Cuerpo	Bronce	
Tapa	Bronce	
Clapeta	Latón	
Asiento	Integral	
Rating	DIN PN32/B, 200 WSP, 400 WOG	
Conexiones	ISO 7, ISO 228 y NPT	

» Otros modelos y materiales, consultar

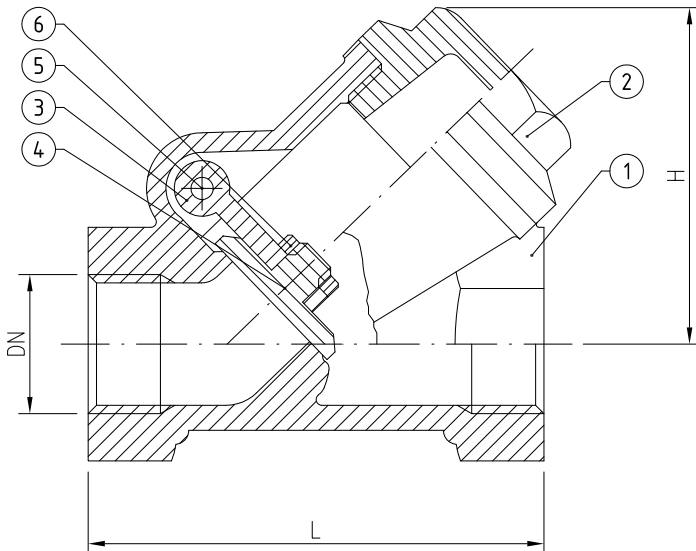

Componentes		
Pos.	Denominación	Material
1	Cuerpo	Bronce CC491K UNI EN 1982
2	Tapa	Bronce CC491K UNI EN 1982
3	Biela	Bronce CC491K UNI EN 1982
4	Clapeta	Latón CW614N UNI EN 12164 (1/4" a 1.1/4") y Bronce CC491K UNI EN 1982 (1.1/2" a 3")
5	Bulón	Latón CW614N UNI EN 12164
6	Tuerca	Latón CW614N UNI EN 12164

FIG. 77204 - RETENCIÓN BRONCE ROSCADA

Código	Tamaño	L	H	Peso (kg.)
-	1/4"	65	45	0,350
-	3/8"	65	45	0,350
-	1/2"	70	50	0,450
-	3/4"	83	60	0,750
-	1"	90	70	0,860
-	1.1/4"	105	75	1,250
-	1.1/2"	125	90	1,750
-	2"	148	105	2,850
-	2.1/2"	180	130	4,350
-	3"	280	160	9,000

BRONCE Y LATÓN

RETENCIÓN BRONCE TIPO BRIDAS

RETENCIÓN BRONCE Tipo Bidas Fig. 80203		Tipo: Bronce y Latón
Válvula Retención en Bronce con Bidas		
Especificaciones		
Cuerpo	Bronce	
Tapa	Latón	
Clapeta	Latón	
Asiento	Integral	
Rating	DIN PN16/B, 100 WSP, 200 WOG	
Conexiones	Bidas	

» Otros modelos y materiales, consultar



Componentes		
Pos.	Denominación	Material
1	Cuerpo	Bronce CC491K UNI EN 1982
2	Tapa	Latón CW614N UNI EN 12164
3	Obturador	Latón CW614N UNI EN 12164
4	Husillo	Latón CW614N UNI EN 12164

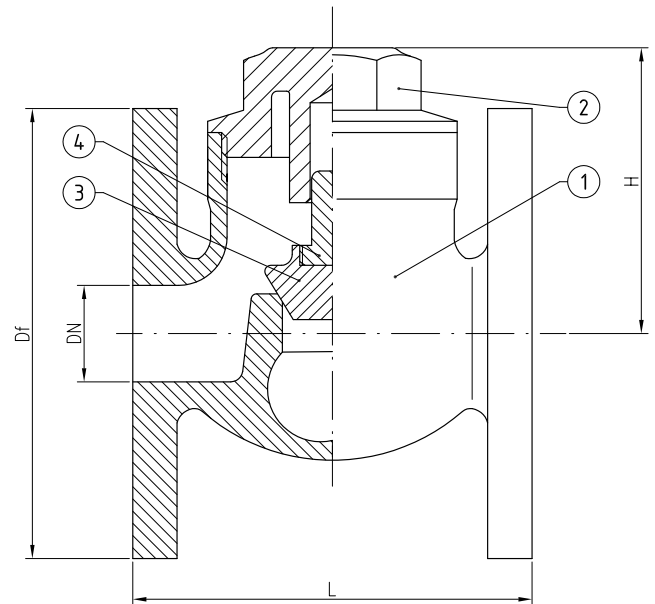

FIG. 80203 - RETENCIÓN BRONCE CON BRIDAS

Código	Tamaño	D	Df	L	H
-	1/2"	55	95	80	60
-	3/4"	60	105	80	65
-	1"	70	115	92	70
-	1.1/4"	80	140	102	80
-	1.1/2"	80	150	118	85
-	2"	95	165	140	90
-	2.1/2"	110	185	160	100
-	3"	130	200	190	110
-	4"	150	220	244	130

RETENCIÓN BRONCE TIPO BRIDAS



RETENCIÓN BRONCE Tipo Bidas Fig. 77404		Tipo: Bronce y Latón
Válvula Retención en Bronce con Bidas		
Especificaciones		
Cuerpo	Bronce	
Tapa	Bronce	
Obturador	Latón	
Asiento	Integral	
Rating	DIN PN16/B, 100 WSP, 200 WOG	
Conexiones	Bidas	

» Otros modelos y materiales, consultar

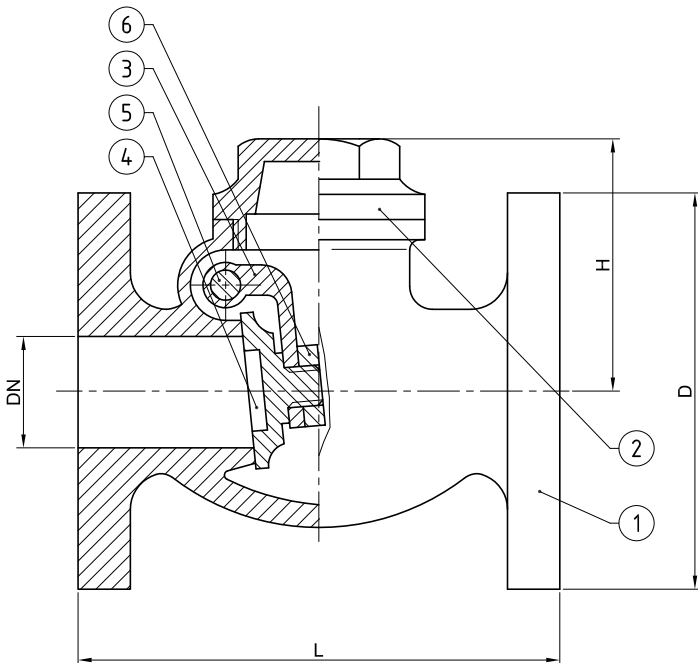

Componentes		
Pos.	Denominación	Material
1	Cuerpo	Bronce C83600 ASTM B62
2	Tapa	Bronce C83600 ASTM B62
3	Bielas	Bronce C83600 ASTM B62
4	Clapeta	Latón CW614N UNI EN 12164 (1/2" a 1.1/4") y Bronce C83600 ASTM B62 (1.1/2" a 4")
5	Bulón	Latón CW614N UNI EN 12164
6	Tuerca	Acero inox X2CrNiMo 17.12.2 UNI EN 10088-3 (3/8" a 2.1/2") y Latón CW614N UNI EN 12164 (3" y 4")

FIG. 77404 - RETENCIÓN BRONCE CON BRIDAS

Código	Tamaño	D	L	H	Peso (kg.)
-	1/2"	95	70	52	1,300
-	3/4"	105	80	56	1,800
-	1"	115	101	60	2,500
-	1.1/4"	140	107	65	3,250
-	1.1/2"	150	121	70	4,400
-	2"	165	150	85	6,400
-	2.1/2"	185	175	95	9,300
-	3"	200	197	125	12,000
-	4"	220	220	145	19,000

BRONCE Y LATÓN

FILTRO Y BRONCE TIPO ROSCADO

FILTRO 'Y' BRONCE Tipo Roscado Fig. 54158		Tipo: Bronce y Latón
Filtro 'Y' en Bronce Roscado		
Especificaciones		
Cuerpo	Bronce	
Tapa	Latón	
Tamiz	Acero inoxidable	
Junta	Betaflex 71	
Rating	DIN PN16/B, 100 WSP, 200 WOG	
Conexiones	ISO 7, ISO 228 y NPT	

» Otros modelos y materiales, consultar



Componentes		
Pos.	Denominación	Material
1	Cuerpo	Bronce CC491K UNI EN 1982
2	Tamiz	Acero inox X5CrNi18.10 UNI EN 10088-3
3	Tapa	Latón CW617N UNI EN 12165
4	Junta	Betaflex 71

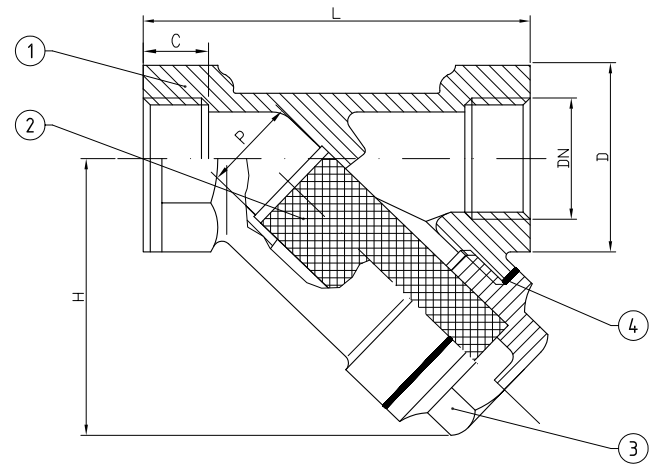

FIG. 54158 - FILTRO 'Y' BRONCE ROSCADO

Código	Tamaño	L	H	C	P	Peso (kg.)	Mesh
-	3/8"	55	42	9	16	0,250	50
-	1/2"	65	42	12	16	0,300	50
-	3/4"	83	45	14	20	0,356	50
-	1"	92	53	15	24	0,480	50
-	1.1/4"	105	65	16	29	0,720	40
-	1.1/2"	115	73	18	37	0,900	40
-	2"	131	95	20	46	1,600	40
-	2.1/2"	146	105	19.5	62	2,500	18
-	3"	172	128	20	68	3,700	18
-	4"	226	178	22	92	6,800	18

FILTRO Y BRONCE TIPO ROSCADO



FILTRO 'Y' BRONCE Tipo Roscado Fig. 54217		Tipo: Bronce y Latón
Filtro 'Y' en Bronce Roscado		
Especificaciones		
Cuerpo	Bronce	
Tapa	Bronce	
Tamiz	Acero inoxidable	
Junta	Fibra	
Rating	DIN PN25/B, 150-200 WSP, 300-400 WOG	
Conexiones	ISO 7, ISO 228 y NPT	

» Otros modelos y materiales, consultar

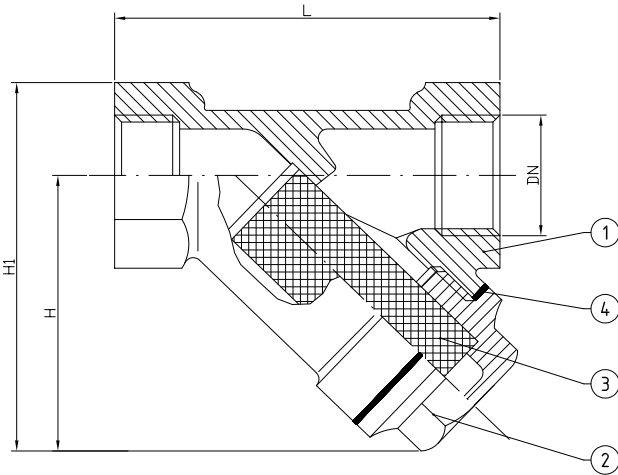

Componentes		
Pos.	Denominación	Material
1	Cuerpo	Bronce CC491K UNI EN 1982
2	Tapa	Bronce CC491K UNI EN 1982
3	Tamiz	Acero inoxidable AISI 304
4	Junta	Fibra

FIG. 54217 - FILTRO 'Y' BRONCE ROSCADO

Código	Tamaño	H	H1	L	Luz	Tal. x cm ²	Mesh	Peso (kg.)
-	3/8"	41	55	55	0,4	262	45	0,260
-	1/2"	46	63	72	0,4	262	45	0,360
-	3/4"	59	80	80	0,4	262	45	0,660
-	1"	66	90	91	0,4	262	45	0,830
-	1.1/4"	75	104	108	0,47	168	36	1,130
-	1.1/2"	88	121	123	0,47	168	36	1,650
-	2"	107	148	148	0,47	168	36	2,600
-	2.1/2"	120	172	189	0,53	133	32	4,430
-	3"	151	212	226	0,53	133	32	7,340
-	4"	200	275	270	0,53	133	32	12,000

BRONCE Y LATÓN

FILTRO Y BRONCE TIPO BRIDAS

FILTRO 'Y' BRONCE Tipo Bidas Fig. 54517		Tipo: Bronce y Latón
Filtro 'Y' en Bronce con Bidas		
Especificaciones		
Cuerpo	Bronce	
Tapa	Bronce	
Tamiz	Acero inoxidable	
Junta	Fibra	
Rating	DIN PN16/B, 100 WSP, 200 WOG	
Conexiones	Bidas	

» Otros modelos y materiales, consultar



Componentes		
Pos.	Denominación	Material
1	Cuerpo	Bronce CC491K UNI EN 1982
2	Tapa	Bronce CC491K UNI EN 1982
3	Tamiz	Acero inoxidable AISI 304
4	Junta	Fibra

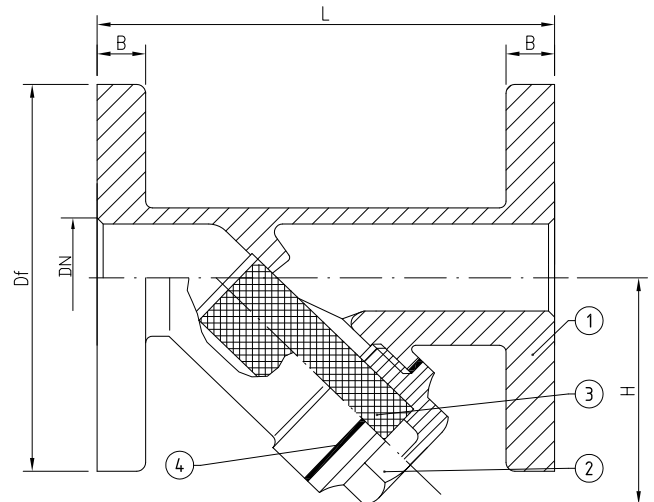

FIG. 54517 - FILTRO 'Y' BRONCE CON BRIDAS

Código	Tamaño	Df	H	L	B	Luz	Tal. x cm ²	Mesh	Peso (kg.)
-	2.1/2"	185	120	234	13	0,53	133	32	11,000
-	3"	200	151	270	14	0,53	133	32	14,200
-	4"	220	200	300	17	0,53	133	32	23,000

VÁLVULA MACHO BRONCE TIPO ROSCADO



VÁLVULA MACHO BRONCE Roscado Fig. 20002		Tipo: Bronce y Latón
Válvula Macho en Bronce Roscada		
Especificaciones		
Cuerpo	Bronce	
Macho	Bronce	
Casquillo	Latón	
Tuerca	Latón	
Rating	DIN PN16/B, 100 WSP, 200 WOG	
Conexiones	ISO 7, ISO 228 y NPT	

» Otros modelos y materiales, consultar

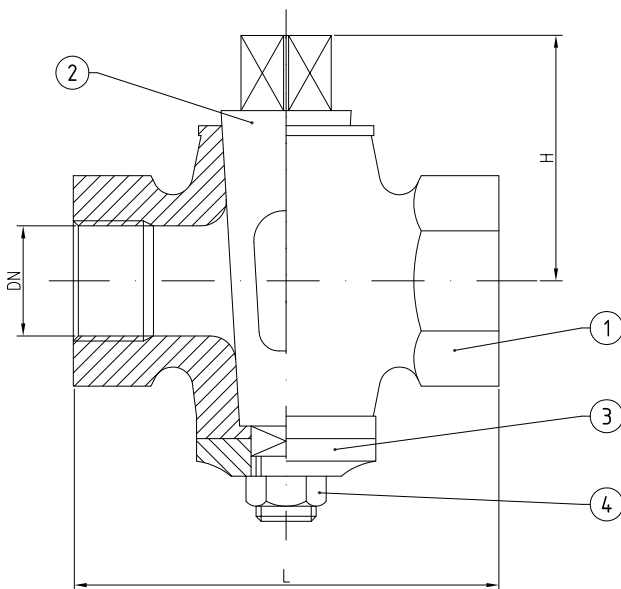

Componentes		
Pos.	Denominación	Material
1	Cuerpo	Bronce C83600 ASTM B62
2	Macho	Bronce C83600 ASTM B62
3	Casquillo	Latón CW614N UNI EN 12164
4	Tuerca	Latón CW614N UNI EN 12164

FIG. 20002 - MACHO BRONCE ROSCADO

Código	Tamaño	L	H	Cuadradillo	Peso (kg.)
-	1/4"	45	35	11	0,160
-	3/8"	52	38	14	0,250
-	1/2"	58	42	14	0,330
-	3/4"	68	50	16	0,520
-	1"	68	55	18	0,700
-	1.1/4"	82	65	23	1,200
-	1.1/2"	96	70	27	1,800
-	2"	107	80	28	2,400
-	2.1/2"	150	100	32	5,000
-	3"	160	110	41	6,700
-	4"	195	135	50	12,200

BRONCE Y LATÓN

VÁLVULA MACHO BRONCE TIPO BRIDAS

VÁLVULA MACHO BRONCE Tipo Bidas Fig. 28101		Tipo: Bronce y Latón
Válvula Macho en Bronce con Bidas		
Especificaciones		
Cuerpo	Bronce	
Macho	Bronce	
Casquillo	Bronce	
Tuerca	Bronce	
Rating	DIN PN16/B, 100 WSP, 200 WOG	
Conexiones	Bidas	

» Otros modelos y materiales, consultar



Componentes		
Pos.	Denominación	Material
1	Cuerpo	Bronce CC491K UNI EN 1982
2	Macho	Bronce CC491K UNI EN 1982
3	Casquillo	Bronce CC491K UNI EN 1982
4	Tuerca	Acero inoxidable

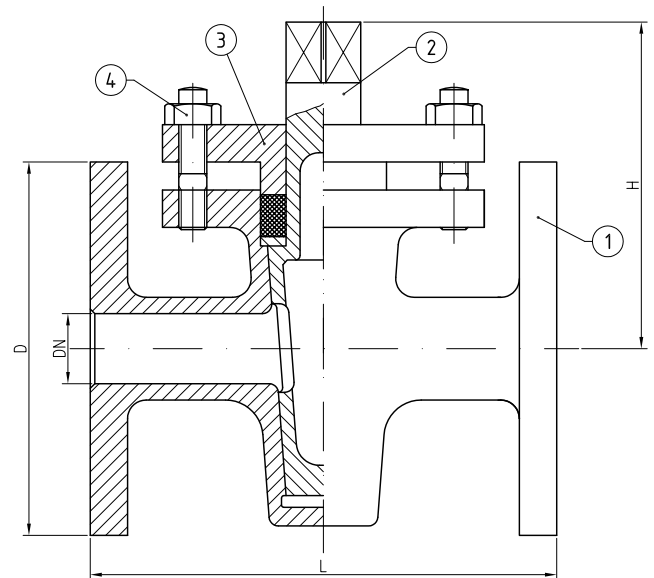

FIG. 28101 - VÁLVULA MACHO BRONCE CON BRIDAS

Código	Tamaño	D	L	H	Peso (kg.)	Cuadradillo
-	3/8"	90	65	65	1,300	12
-	1/2"	95	75	70	1,700	12
-	3/4"	105	85	80	2,400	16
-	1"	115	100	90	3,100	18
-	1.1/4"	140	110	110	5,100	20
-	1.1/2"	150	130	130	7,300	24
-	2"	165	150	150	9,000	27
-	2.1/2"	185	200	180	17,000	32
-	3"	200	220	200	20,000	32
-	4"	220	270	250	33,000	41

APÉNDICES

TABLAS DE RESISTENCIA A LA CORROSIÓN.....	416
SAIDI, la empresa KLINGER en España.....	422
Juntas recomendadas	423
Catálogo técnicos División Sealing	427
Ejecuciones especiales.....	428
Conexiones auxiliares	431
Dimensiones extremos para soldar	432
Dimensiones bridas ANSI	433
Dimensiones bridas ASME.....	434
Dimensiones bridas DIN	435
Acabado superficies bridas DIN.....	437
Tablas Presión / Temperatura.....	438
Abreviaturas técnicas	442
Especificaciones del Trim.....	443
Tablas de equivalencias de materiales.....	444
Tablas de conversión	445
SAIDI Outsourcing	447
Red de Delegaciones	448

INFORMACIÓN TÉCNICA

TABLAS DE RESISTENCIA A LA CORROSIÓN

E	Excelente resistencia (Excellent resistance)
G	Buena resistencia (Good resistance)
M	Resistencia moderada (Moderate resistance)
X	No se recomienda (Not recommended)

	304 Stainless Steel	316 Stainless Steel	Cast Iron	Carbon Steel	PTFE
Medio					
Acetaldehyde	E	E	-	M	E
Acetamide	G	E	-	M	-
Acetate Solv.	G	E	G	E	E
Acetic Acid, Glacial	G	E	X	E	E
Acetic Acid 20%	-	E	-	-	E
Acetic Acid 80%	-	E	-	-	E
Acetic Acid	G	E	X	M	E
Acetic Anhydride	E	E	G	X	E
Acetone	E	E	E	E	E
Acetyl Chloride	M	E	-	-	E
Acetylene	E	E	E	E	-
Acrylonitrile	E	M	M	-	-
ALCOHOLS					
Ethyl	E	E	M	M	E
Genzyl	E	E	-	-	-
Gutyl	E	E	M	M	E
XiMetone	E	E	-	E	-
Ethyl	E	E	E	E	-
Hexyl	E	E	-	E	-
IsoGutyl	E	E	-	E	-
Isopropyl	E	E	M	E	-
Methyl	E	E	E	E	E
OMtyl	E	E	-	E	-
Propyl	E	E	-	E	E
Aluminium Chloride 20%	X	M	X	E	-
Aluminium Chloride	X	M	X	G	E
Aluminium Flouride	X	M	-	E	E
Aluminium Hydroxide	E	E	X	E	E
Alum Potassium Sulphate (ALUM), 10%	E	-	X	E	E
Alum Potassium Sulphate (ALUM) 100%	X	E	-	E	E

	304 Stainless Steel	316 Stainless Steel	Cast Iron	Carbon Steel	PTFE
Medio					
Aluminium Sulphate	M	M	X	E	E
Amines	E	E	E	G	E
Ammonia 10%	-	E	-	-	E
Ammonia Anhydrous	G	E	X	G	E
Ammonia, Liquids	E	E	E	E	E
Ammonia, Nitrate	E	E	-	E	-
Ammonium Bifluoride	M	E	-	-	-
Ammonium Carbonate	E	E	M	G	E
Ammonium Casenite	-	E	-	-	-
Ammonium Chloride	E	M	X	X	E
Ammonium Hydroxide	E	E	E	M	E
Ammonium Nitrate	E	E	E	X	E
Ammonium Oxalate	E	E	-	E	-
Ammonium Persulfate	E	E	X	E	E
Ammonium Phosphate, Dibasic	E	E	-	X	E
Ammonium Phosphate, Monobasic	E	E	-	E	E
Ammonium Phosphate, Tribasic	E	E	M	X	E
Ammonium Sulphate	E	G	M	M	E
Ammonium Thio-Sulphate	-	E	X	E	-
Amyl-Acetate	E	E	-	M	E
Amyl Alcohol	E	E	-	E	E
Amyl Chloride	M	G	-	E	E
Aniline	E	E	-	M	E
Anti-Freeze	E	E	G	M	E
Antimony Trichloride	X	X	-	-	E
Aqua Regia (80%, HCl, 20%, HNO)	X	X	-	-	E
Arochlor 1248	-	-	-	E	-
Aromatic Hydrocarbons	-	E	E	E	-
Arsenic Acid	E	E	X	X	E
Asphalt	G	E	M	-	-

Medio	304 Stainless Steel	316 Stainless Steel	Cast Iron	Carbon Steel	PTFE
Barium Carbonate	E	E	G	G	E
Barium Chloride	E	E	N	M	E
Barium Cyanide	-	E	-	E	-
Barium Hydroxide	M	E	M	M	E
Barium Nitrate	E	E	E	E	-
Barium Sulphate	E	E	M	M	E
Barium Sulphide	E	E	M	M	E
Beer	E	E	X	X	E
Beet Sugar Liquids	E	E	E	-	E
Benzaldehyde	E	E	G	E	E
Benzene	E	E	G	M	E
Benzoic Acid	E	E	X	-	E
Benzol	E	E	-	-	E
Borax (Sodium Borate)	E	E	E	M	E
Boric Acid	E	E	X	-	E
Brewery Slop	-	E	E	-	-
Bromine (Wet)	X	X	X	X	E
Butadiene	E	E	M	M	E
Butanes	E	E	M	M	E
Butanol	E	E	-	-	E
Butter	G	E	X	-	-
Buttermilk	E	E	X	-	E
Butylene	-	E	E	E	E
Butyl Acetate	-	M	-	E	E
Butyric Acid	G	E	X	-	E
Calcium Bisulphate	X	E	X	-	E
Calcium Bisulphide	-	G	-	-	E
Calcium Bisulphite	X	E	-	-	E
Calcium Carbonate	E	E	X	-	E
Calcium Chlorate	M	E	-	-	E
Calcium Chloride	E	X	M	-	E
Calcium Hydroxide	E	E	-	-	E
Calcium Hypochlorite	E	M	X	-	E
Calcium Sulphate	E	E	-	-	E
Calgon	E	E	X	-	-
Cane Juice	E	E	E	-	-
Carbolic Acid (See Phenol)	-	-	-	-	-
Carbon Bisulphide	E	E	G	-	-

Medio	304 Stainless Steel	316 Stainless Steel	Cast Iron	Carbon Steel	PTFE
Carbon Dioxide (Wet)	E	E	M	-	E
Carbon Disulphide	G	E	G	M	E
Carbon Monoxide	E	E	-	-	-
Carbon Tetrachloride	M	G	M	X	E
Carbonated Water	E	E	X	-	-
Carbonic	E	G	X	-	E
Catsup	E	E	X	-	-
Chloracetic Acid	X	X	X	-	E
Chloric Acid	X	X	-	-	E
Chlorinated Glue	E	E	X	-	-
Chlorine, Anhydrous Liquid	X	X	M	-	E
Chlorine (Dry)	E	E	E	-	E
Chlorine Water	-	X	X	-	E
Chlorobenzene (Mono)	E	E	G	M	E
Chlorosulphonic Acid	X	-	-	X	E
Chlorox (Bleach)	E	E	X	M	E
Chocolate Syrup	E	E	X	-	-
Chromic Acid 5%	E	E	X	-	-
Chromic Acid 10%	G	-	-	-	E
Chromic Acid 30%	G	-	-	-	E
Chromic Acid 50%	G	G	X	-	E
Cider	E	E	X	-	-
Citric Acid	E	E	X	-	E
Citric Oils	E	E	-	-	-
Coffee	E	E	M	-	E
Copper Chloride	X	X	X	-	E
Copper Cyanide	E	E	X	-	E
Copper Floborate	X	X	X	-	E
Copper Nitrate	E	E	-	-	E
Copper Sulphate (5% Solution)	E	E	X	-	E
Copper Sulphate	G	-	-	-	E
Cream	E	E	X	-	-
Cresols	E	E	-	-	-
Cresylic Acid	E	E	-	-	E
Cyclohexane	E	-	-	E	-
Cyanic Acid	E	-	-	-	-
Detergents	E	E	-	E	-
Dichlorethane	E	E	-	-	E

INFORMACIÓN TÉCNICA

TABLAS DE RESISTENCIA A LA CORROSIÓN

Medio	304 Stainless Steel	316 Stainless Steel	Cast Iron	Carbon Steel	PTFE
Diesel Fuel	E	E	E	E	-
Diethylamine	E	-	-	-	E
Diethylene Glycol	E	-	-	-	-
Diphenyl Oxide	E	-	-	-	-
Dyes	E	E	-	-	-
Magnesium Sulphate	E	E	-	-	-
Ethane	E	-	-	-	-
Ethanolamine	E	E	-	M	-
Ether	E	E	-	X	-
Ethyl Acetate	E	E	-	M	E
Ethyl Chloride	E	E	M	X	E
Ethyl Sulphate	X	-	-	-	-
Ethylene Chloride	E	E	M	M	E
Ethylene Dichloride	E	E	-	M	E
Ethylene Glycol	E	E	G	M	E
Ethylene Oxide	-	E	-	-	E
Fatty Acids	E	E	X	-	E
Ferric Chloride	X	X	X	-	E
Ferric Nitrate	E	E	-	-	E
Ferric Sulphate	E	M	X	-	E
Ferrous Chloride	X	X	X	-	E
Ferrous Sulphate	E	M	X	X	E
Fluoroboric Acid	X	G	X	-	E
Fluorine	X	X	X	X	M
Fluosilicic Acid	-	G	X	-	E
Formaldehyde 40%	-	E	-	-	E
Formaldehyde	E	E	X	E	E
Formic Acid	E	G	X	X	E
Freon 11	-	E	M	G	E
Freon 12 (wet)	-	X	-	-	E
Freon 22	-	E	-	-	-
Freon 113	-	E	-	-	-
Freon T.F.	-	E	-	-	-
Fruit Juice	E	E	X	X	X
Fuel Oils	E	E	M	G	E
Furan Resin	E	E	E	E	E
Furfural	E	E	-	E	E
Gallic Acid	E	E	X	X	E

Medio	304 Stainless Steel	316 Stainless Steel	Cast Iron	Carbon Steel	PTFE
Gasoline	E	E	E	E	E
Gelatin	E	E	X	X	E
Glucose	-	E	G	G	E
Glue P.V.A.	G	E	-	E	E
Glycerine	E	E	G	G	E
Cycolic Acid	-	-	-	-	-
Gold Monocyanide	-	E	X	-	-
Grape Juice	E	E	X	-	-
Grease	E	E	E	E	E
Heptane	-	E	-	G	E
Hexane	E	E	-	G	E
Honey	E	E	E	-	-
Hydraulic Oils (Petroleum)	E	E	E	E	E
Hydraulic Oils (Synthetic)	E	E	E	-	-
Hydrazine	E	E	M	-	-
Hydrobromic Acid 20%	-	X	-	-	E
Hydrobromic Acid	X	X	X	X	E
Hydrochloric Acid (Dry Gas)	M	E	-	X	E
Hydrochloric Acid (20%)	X	X	X	-	E
Hydrochloric Acid (37%)	X	X	X	-	E
Hydrochloric Acid 100%	X	X	X	-	E
Hydrocyanic Acid	E	E	-	M	E
Hydrocyanic Acid (Gas 10%)	X	X	-	-	E
Hydrofluoric Acid (20%)	X	X	X	-	E
Hydrofluoric Acid (75%)	M	X	X	-	E
Hydrofluoric Acid 100%	X	X	X	X	E
Hydrofluosilicic Acid (20%)	X	X	X	-	E
Hydrofluosilicic Acid	X	X	-	-	E
Hydrogen Gas	E	E	G	G	E
Hydrogen Peroxide 10%	M	M	X	-	E
Hydrogen Peroxide 30%	-	G	-	-	E
Hydrogen Peroxide	E	G	X	X	E
Hydrogen Sulphide, Aqueous Solution	E	E	X	-	E
Hydrogen Sulphide (Dry)	M	E	G	G	E
Hydroxyacetic Acid (70%)	-	-	-	-	-
Ink	E	E	X	X	-
Iodine	X	X	X	-	E
Iodine (In Alcohol)	-	G	-	-	E

Medio	304 Stainless Steel	316 Stainless Steel	Cast Iron	Carbon Steel	PTFE
Iodoform	X	E	M	G	E
Isotane	-	-	-	-	-
Isopropyl Acetate	-	G	-	-	-
Isopropyl Ether	-	E	-	E	E
Jet Fuel (JP3,JP4,JP5)	E	E	E	E	E
Kerosene	E	E	E	G	E
Ketones	E	E	E	E	E
Lacquers	E	E	M	M	-
Lacquer Thinners	-	E	-	-	E
Lactic Acid	E	G	X	X	E
Lard	E	E	E	M	-
Latex	E	E	-	-	-
Lead Acetate	E	E	-	X	E
Lead Sulphamate	-	-	-	-	-
Ligroin	-	E	-	-	-
Lime	E	E	E	-	-
Lubricants	E	E	-	-	E
Magnesium Carbonate	E	E	-	-	-
Magnesium Chloride	G	G	X	M	E
Magnesium Hydroxide	E	E	G	G	E
Magnesium Nitrate	E	E	-	-	E
Magnesium Oxide	E	E	-	-	-
Magnesium Sulphate	G	E	M	G	E
Maleic Acid	E	E	-	G	E
Maleic Anhydride	-	-	-	-	-
Malic Acid	E	E	-	X	E
Mash	E	E	-	-	-
Mayonnaise	E	E	X	X	E
Melamine	X	X	-	-	-
Mercuric Chloride (Dilute Solution)	X	X	X	X	E
Mercuric Cyanide	E	E	-	X	E
Mercury	E	E	E	E	E
Methanol (See Alcohol Methyl)	-	-	-	-	-
Methyl Acetate	-	E	-	G	E
Methyl Acrylate	-	-	-	-	-
Methyl Acetone	-	E	E	E	E
Methyl Alcohol 10%	-	E	-	G	E
Methyl Bromide	-	-	-	-	-

Medio	304 Stainless Steel	316 Stainless Steel	Cast Iron	Carbon Steel	PTFE
Methyl Butyl Ketone	-	E	-	-	-
Methyl Cellosolve	-	-	-	-	-
Methyl Chloride	M	E	-	-	E
Methyl Dichloride	-	-	-	-	-
Methyl Ethyl Ketone	E	E	-	-	E
Methyl Isobutyl Ketone 2	-	E	-	-	E
Methyl Isopropyl Ketone	-	E	-	-	-
Methyl Methacrylate	-	-	-	-	-
Methylamine	-	E	G	G	-
Methylene Chloride	E	E	-	G	E
Milk	E	E	X	X	-
Molasses	E	E	E	E	-
Mustard	E	E	M	G	-
Naptha	E	E	G	G	E
Napthalene	E	G	G	E	E
Nickel Chloride	E	G	X	-	E
Nickel Sulphate	E	G	X	X	E
Nitric Acid (10% Solution)	E	E	X	X	E
Nitric Acid (20% Solution)	E	E	X	-	E
Nitric Acid (50% Solution)	E	E	X	-	E
Nitric Acid (Concentrated Solution)	X	G	X	-	E
Nitrobenzene 2	E	G	G	G	E
OILS					
OILS Eniline	E	E	E	-	E
Enise	E	E	-	-	-
GEy	E	E	-	-	-
Gone	E	E	-	-	-
MEstor	E	E	E	-	-
MinnEmon	E	E	-	-	E
MitriM	E	E	X	-	-
Mlove	E	E	-	-	-
MoMonut	E	E	E	-	-
MoX Liver	E	E	-	-	-
Mom	E	E	E	-	-
Motton SeeX	E	E	E	M	E
Mresote	E	E	-	-	-
Xiesel Fuel (2X,3X,4X,5X)	E	E	-	-	-
Fuel (1,2,3,5E,5G,6)	E	E	-	-	E

INFORMACIÓN TÉCNICA

TABLAS DE RESISTENCIA A LA CORROSIÓN

Medio	304 Stainless Steel	316 Stainless Steel	Cast Iron	Carbon Steel	PTFE
Ginger	E	E	-	-	-
HyXrEuliM (See HyXrEuliM)				-	
Lemon	E	E	-	-	-
LinseeX	E	E	E	-	-
MinerEl	E	E	E	G	-
Olive	E	E	E	G	E
OrEnge	E	E	-	-	E
PEIm	E	E	-	-	-
PeEnut	E	E	E	-	-
Peppermint	E	E	-	-	-
Pine	E	E	M	G	E
REpe SeeX	E	E	-	-	-
Rosin	E	E	-	-	-
SesEme SeeX	E	E	E	-	-
SilliMone	E	E	E	-	-
SoyGeEn	E	E	E	-	-
Sperm	E	E	-	-	-
TEnning	E	E	-	-	-
TurGine	E	E	E	-	-
Oleic Acid	E	E	M	M	E
Oleum 25%	-	-	-	-	E
Oleum	-	E	-	G	E
Oxalic Acid (cold)	E	G	X	X	E
Paraffin	E	E	G	G	E
Pentane	M	M	G	G	E
Perchloroethylen	E	E	G	G	E
Petrolatum	-	E	M	M	E
Phenol 10%	E	E	G	X	E
Phenol (Carbolic Acid)	E	E	X	X	E
Phosphoric Acid (to 40% Solution)	G	E	X	-	E
Phosphoric Acid (40%-100% Solution)	M	G	X	-	E
Phosphoric Acid (Crude)	X	M	X	X	E
Phosphoric Anhydride (Dry or Moist)	E	E	-	-	E
Phosphoric Anhydride (Molten)	E	E	-	-	E
Photographic (Developer)	M	E	X	-	-
Phthalic Anhydride	E	G	M	M	E
Picric Acid	E	E	X	X	E
Potash	E	-	G	-	-

Medio	304 Stainless Steel	316 Stainless Steel	Cast Iron	Carbon Steel	PTFE
Potassium Bicarbonate	E	-	X	-	E
Potassium Bromide	E	-	X	X	E
Potassium Carbonate	E	-	G	G	E
Potassium Chlorate	E	E	G	G	E
Potassium Chloride	E	E	G	G	E
Potassium Chromate	-	G	E	-	-
Potassium Cyanide Solutions	E	G	G	G	E
Potassium Dichromate	E	E	G	M	E
Potassium Ferrocyanide	E	-	-	M	E
Potassium Hydroxide (50%)	G	G	M	E	E
Potassium Nitrate	E	G	-	G	E
Potassium Permanganate	E	G	G	G	E
Potassium Sulphate	E	G	G	G	E
Potassium Sulphide	E	-	G	G	E
Propane (Liquified)	E	-	-	G	E
Propylene Glycol	G	-	G	G	E
Pyridine	M	-	G	E	E
Pyrogallic Acid	E	E	G	G	E
Rosins	E	E	-	M	E
Rum	E	-	-	-	-
Rust Inhibitors	E	-	E	-	-
Salad Dressing	E	-	X	-	-
Sea Water	E	M	-	X	E
Shellac (Bleached)	E	-	G	E	E
Shellac (Orange)	E	-	M	E	E
Silicone	G	-	-	-	-
Silver Bromide	M	M	-	-	-
Silver Nitrate	E	G	X	X	E
Soap Solutions	E	E	G	E	E
Soda Ash (See Sodium Carbonate)					
Sodium Acetate	E	E	M	M	E
Sodium Aluminate	-	-	-	M	E
Sodium Bicarbonate	E	E	M	M	E
Sodium Bisulphate	E	-	X	X	E
Sodium Bisulphite	E	-	X	-	E
Sodium Borate	E	-	M	M	E
Sodium Carbonate	E	G	G	G	E
Sodium Chlorate	E	-	-	M	E

Medio	304 Stainless Steel	316 Stainless Steel	Cast Iron	Carbon Steel	PTFE
Sodium Chloride	E	M	G	M	E
Sodium Chromate	E	E	G	G	E
Sodium Cyanide	E	-	G	G	E
Sodium Fluoride	M	-	X	X	E
Sodium Hydrosulphite	-	-	-	-	E
Sodium Hydroxide (20%)	E	E	E	-	E
Sodium Hydroxide (50% Solution)	E	G	G	-	E
Sodium Hydroxide (80% Solution)	E	X	M	-	E
Sodium Hypochlorite 3 (to 20%)	M	M	X	-	E
Sodium Hypochlorite	-	E	X	X	E
Sodium Hyposulphate	E	E	-	-	E
Sodium Metaphosphate	-	E	G	G	E
Sodium Metasilicate	-	E	M	M	E
Sodium Nitrate	E	E	E	G	E
Sodium Perborate	-	M	G	G	E
Sodium Peroxide	E	E	X	M	E
Sodium Polyphosphate (Mono, Di, Tribasic)	E	E	-	-	E
Sodium Silicate	E	G	-	G	E
Sodium Sulphate	E	E	E	G	E
Sodium Sulphide	E	G	E	G	E
Sodium Sulphite	M	M	E	-	E
Sodium Tetraborate	-	E	-	-	-
Sodium Thiosulphate ("Hypo")	E	E	M	G	E
Sorghum	E	E	E	-	-
Soy Sauce	E	E	X	-	-
Stannic Chloride	X	X	X	X	E
Stannic Fluoborate	-	E	X	-	-
Stannous Chloride	X	M	X	X	E
Starch	E	E	M	M	E
Stearic Acid	E	E	M	M	E
Stoddard Solvent	E	E	G	G	E
Styrene	E	E	-	E	E
Sugar (Liquids)	E	E	G	G	E
Sulphate Liquors	M	M	-	-	-
Sulphur Chloride	X	X	-	-	E
Sulphur Dioxide	E	E	-	-	E
Sulphur Dioxide (Dry)	E	E	E	G	E
Sulphur Trioxide (Dry)	E	M	G	G	E

Medio	304 Stainless Steel	316 Stainless Steel	Cast Iron	Carbon Steel	PTFE
Sulphuric Acid (to 10%)	X	M	X	-	E
Sulphuric Acid (10%-75%)	X	X	X	-	E
Sulphuric Acid 75%-100%	-	X	-	-	E
Sulphurous Acid	M	G	X	X	E
Sulphuryl Chloride	-	-	-	-	E
Syrup	E	E	-	-	-
Tallow	E	E	-	-	-
Tannic Acid	E	E	M	M	E
Tanning Liquors	E	E	-	-	E
Tartaric Acid	E	G	X	X	E
Tetrachlorethane	-	E	-	-	E
Tetrahydrofuran	E	E	X	E	E
Toluene, Toluol	E	E	E	E	E
Tomato Juice	E	E	M	M	E
Trichlorethane	M	E	M	-	E
Trichlorethylene	E	E	M	G	E
Trichloropropane	-	E	-	-	-
Tricresylphosphate	-	E	-	-	E
Triethylamine	-	-	-	-	-
Turpentine	E	E	G	G	E
Urine	E	E	G	-	-
Vegetable Juice	E	E	X	-	-
Vinegar	E	E	M	X	E
Varnish (Use Viton® for Aromatic)	E	E	-	M	E
Water, Acid, Mine	E	E	M	-	-
Water, Distilled, Lab Grade 7	E	E	X	-	E
Water, Fresh	E	E	G	X	E
Water, Salt	E	E	X	-	-
Weed Killers	E	E	-	-	-
Whey	E	E	-	-	-
Whiskey and Wines	E	E	X	X	E
White Liquor (Pulp Mill)	E	E	M	-	E
White Water (Paper Mill)	E	E	-	-	-
Xylene	E	E	E	G	E
Zinc Chloride	E	G	X	X	E
Zinc Hydrosulphite	-	E	X	-	-
Zinc Hydrosulphate	E	E	M	X	E
Zinc Sulphate	E	E	M	X	E



PRESENTACIÓN DE SAIDI

La empresa KLINGER en España

Desde 1970, SAIDI es la empresa de referencia en **Control de Fluidos** (Válvulas, Accesorios, Tecnologías de Sellado). Formamos parte de KLINGER®, una multinacional con más de cien años de historia y una gran reputación, con presencia en más de 40 países por todo el mundo.

Nuestro concepto de negocio abarca tanto **Proyectos** –Total Valve Management– como **MRO** (Maintenance Repair Operations) para la gestión y el mantenimiento de plantas industriales. Ofrecemos soluciones específicas para cada tipo de industria (Petroquímica y Refino, Oil & Gas, Química y Farmacia, Energía / Termosolar, Agua y Desalación, Pasta y Papel, Minería y Cemento, Acero y Siderometalurgia, Industria naval, Biocomustibles y Biomasa, Alimentación...)



CIFRAS Y DATOS

Nuestro mundo en cifras



Sealing Technologies

JUNTAS RECOMENDADAS

KLINGERSIL® C-4430 PN10

- » **Material:** Fibra de vidrio con base de goma nitrílica NBR.
- » **Aplicaciones:** Altas temperaturas con vapor, aceite, hidrocarburos y agua. Buena estanqueidad al gas. Uso para Servicios generales.



Más información en nuestro catálogo de Sellado KLINGER®



Juntas KLINGERSIL® C-4430 DIN 2690 PN10 RF 2,0mm

Código	DN	Rating	Medidas	Pack
030626124190365	10	PN10/40	45 x 18	20
030626100820100	15	PN10/40	50 x 22	20
030626100820101	20	PN10/40	60 x 28	20
030626100820102	25	PN10/40	70 x 35	20
030626100820103	32	PN10/40	82 x 43	10
030626100820105	40	PN10/40	92 x 49	10
030626100820106	50	PN10/40	107 x 61	10
030626100820107	65	PN10/40	127 x 77	10
030626100820108	80	PN10/40	142 x 90	10
030626100820109	100	PN10/16	162 x 115	5
030626100820110	125	PN10/16	192 x 141	5
030626100820112	150	PN10/16	218 x 169	5
030626100820099	200	PN10/16	273 x 220	5
030626100820114	250	PN10	328 x 274	5
030626124190231	300	PN10	378 x 325	5
030626124190334	350	PN10	438 x 368	5
030626124190383	400	PN10	490 x 420	5
030626124190335	450	PN10	540 x 470	5
030626124190317	500	PN10	595 x 520	5
030626124190384	600	PN10	695 x 620	5

Sealing Technologies

JUNTAS RECOMENDADAS

KLINGERSIL® C-4324 PN10

- » **Material:** Fibra de aramida y vidrio con goma NBR.
- » **Aplicaciones:** Servicios de aceite, hidrocarburos, vapor a baja presión y Agua potable.



Juntas KLINGERSIL® C-4324 DIN 2690 PN10 RF 2,0mm

Código	DN	Rating	Medidas	Pack
030626100820146	10	PN10/40	45 x 18	20
030626100820097	15	PN10/40	50 x 22	20
030626100820096	20	PN10/40	60 x 28	20
030626100820095	25	PN10/40	70 x 35	20
030626100820094	32	PN10/40	82 x 43	10
030626100820093	40	PN10/40	92 x 49	10
030626100820078	50	PN10/40	107 x 61	10
030626100820120	65	PN10/40	127 x 77	10
030626100820119	80	PN10/40	142 x 90	10
030626100820118	100	PN10/16	162 x 115	5
030626100820117	125	PN10/16	192 x 141	5
030626100820111	150	PN10/16	218 x 169	5
030626100820116	200	PN10/16	273 x 220	5
030626100820115	250	PN10	328 x 274	5
-	300	PN10	378 x 325	5
030626124190172	350	PN10	438 x 368	5
030626124190173	400	PN10	490 x 420	5
-	450	PN10	540 x 470	5
030626124190182	500	PN10	595 x 520	5
-	600	PN10	695 x 620	5

Sealing Technologies

JUNTAS RECOMENDADAS

KLINGERSIL® top-chem-2005 PN10

- » **Material:** PTFE modificado y fibras de material inorgánico.
- » **Color:** Rojo ladrillo ambas caras.
- » **Aplicaciones:** Una amplia gama de aplicaciones en la Industria química, incluyendo ácidos fuertes.



Juntas KLINGER® top-chem-2005 DIN 2690 PN10 RF 2,0mm

Código	DN	Rating	Medidas
030636100820002	10	PN10/40	45 x 18
030636100820003	15	PN10/40	50 x 22
030636100820004	20	PN10/40	60 x 28
030636100820001	25	PN10/40	70 x 35
030636100820005	32	PN10/40	82 x 43
030636100820006	40	PN10/40	92 x 49
030626100820187	50	PN10/40	107 x 61
030626100820188	65	PN10/40	127 x 77
030626100820189	80	PN10/40	142 x 90
030626100820190	100	PN10/16	162 x 115
030626100820191	125	PN10/16	192 x 141
030626100820192	150	PN10/16	218 x 169
030636100820000	200	PN10/16	273 x 220
030626100820193	250	PN10	328 x 274
-	300	PN10	378 x 325
-	350	PN10	438 x 368
-	400	PN10	490 x 420
-	450	PN10	540 x 470
-	500	PN10	595 x 520
-	600	PN10	695 x 620

Sealing Technologies

JUNTAS RECOMENDADAS

KLINGER® PSM Grafito laminado PN10

- » **Material:** Grafito puro laminado reforzado con lámina de acero inoxidable perforada.
- » **Color:** Gris ambas caras.
- » **Aplicaciones:** Una amplia gama de aplicaciones de sellado industrial que incluye vapor, agua caliente, aceite térmico e hidrocarburos. Excelente resistencia química y térmica, hasta 550°C.



Juntas KLINGER® PSM DIN 2690 PN10 RF 2,0mm

Código	DN	Rating	Medidas	Pack
030637124190030	10	PN10/40	45 x 18	20
030637100820019	15	PN10/40	50 x 22	20
030637100820011	20	PN10/40	60 x 28	20
030637100820010	25	PN10/40	70 x 35	20
030637100820020	32	PN10/40	82 x 43	10
030637100820016	40	PN10/40	92 x 49	10
030637100820009	50	PN10/40	107 x 61	10
030637100820018	65	PN10/40	127 x 77	10
030637100820017	80	PN10/40	142 x 90	10
030637100820014	100	PN10/16	162 x 115	5
030637100820015	125	PN10/16	192 x 141	5
030637100820024	150	PN10/16	218 x 169	5
030637100820012	200	PN10/16	273 x 220	5
030637100820013	250	PN10	328 x 274	5
030637124190016	300	PN10	378 x 325	5
-	350	PN10	438 x 368	5
030637124190034	400	PN10	490 x 420	5
-	450	PN10	540 x 470	5
-	500	PN10	595 x 520	5
-	600	PN10	695 x 620	5

CATÁLOGOS TÉCNICOS DIVISIÓN SEALING



Overview con toda la gama de productos de Sealing:

- » Planchas de fibras
- » Planchas de fibras de segunda generación
- » Planchas de PTFE
- » Grafito y Mica
- » Papel aceitado y corcho
- » Cinta adhesiva de PTFE
- » Material elastomérico
- » Empaquetaduras
- » Juntas cortadas
- » Juntas semi-metálicas
- » Cierres mecánicos
- » Juntas aislantes
- » Juntas de goma/metal
- » Juntas tóricas
- » Retenes y juntas labiales
- » Aislamiento
- » Protectores de bridas



Catálogo de juntas y tecnologías de Sellado KLINGER®

- » **Plancha:** Fichas técnicas de la mayoría de plancha estándar (C-4324, C-4400, C-4430, C-4500, C-4509, C-8200, top-graph-2000, top-sil-ML1, top-chem-2000, 2003, 2005, 2006, soft-chem, milam-PSS, Grafito PSM y SLS, statite, PTFE expandido y máquina cortadora de juntas)
- » **Juntas:** Fichas técnicas detalladas de juntas para bridas DIN PN10 y ASA 150LBS.
- » **Juntas metálicas:** Juntas espirometálicas KLINGER® “Maxiflex”, Juntas KLINGER® “Maxiprofile”, Juntas semi-metálicas KLINGER® y Juntas metálicas RTJ KLINGER®.
- » **Empaquetaduras KLINGER® Topline:** Gore GFO® con grafito, PTFE lubricado, Carbón/Grafito y Grafito expandido, sintéticas e híbridas.
- » **Otros materiales**



Overview de juntas y tecnologías de Sellado KLINGER®

- » **Plancha:** Fichas técnicas resumidas de la mayoría de plancha estándar (C-4430, C-4324, C-4400, C-4500, C-4509, C-8200, statite, top-graph-2000, top-sil-ML1, top-chem-2000 y 2003, soft-chem, SLS, PSM y milam-PSS) con diagramas P/T de Presión/Temperatura.
- » **Empaquetadura KLINGER®:** Información técnica y características de la mayoría de referencias.
- » **Juntas metálicas y semi-metálicas KLINGER®:** Juntas espirometálicas “Maxiflex”, juntas “Maxiprofile”, Metaloplásticas y RTJ.

INFORMACIÓN TÉCNICA

EJECUCIONES ESPECIALES

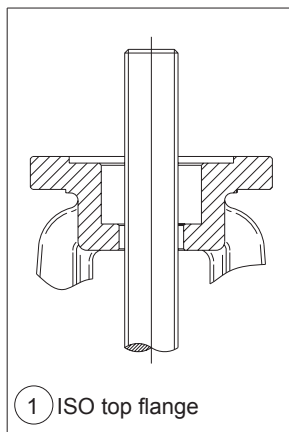

1 ISO top flange

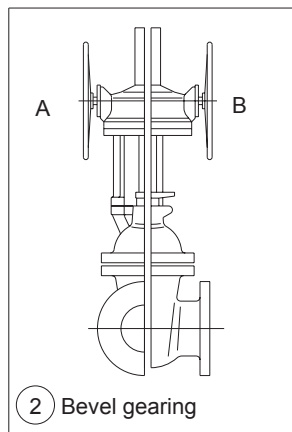

2 Bevel gearing

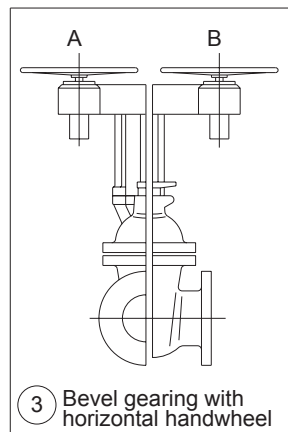

3 Bevel gearing with horizontal handwheel

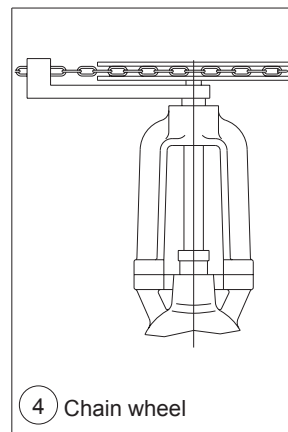

4 Chain wheel

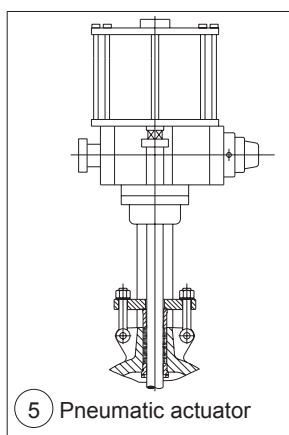

5 Pneumatic actuator

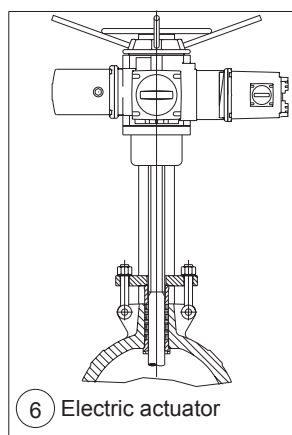

6 Electric actuator

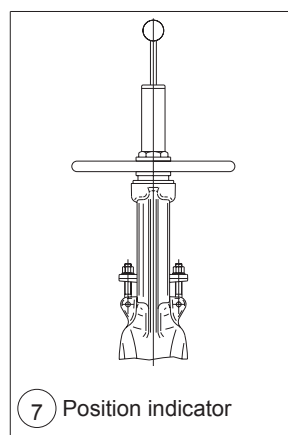

7 Position indicator

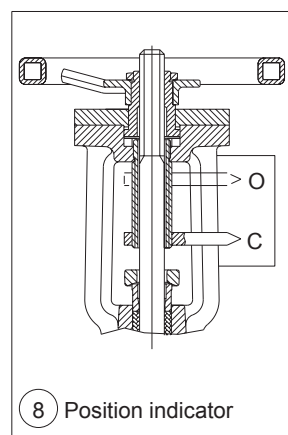

8 Position indicator

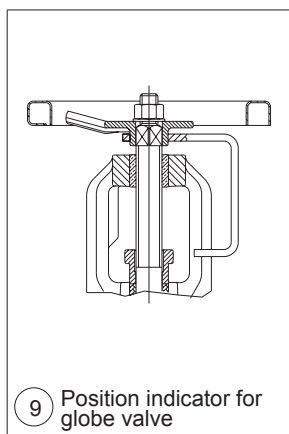

9 Position indicator for globe valve

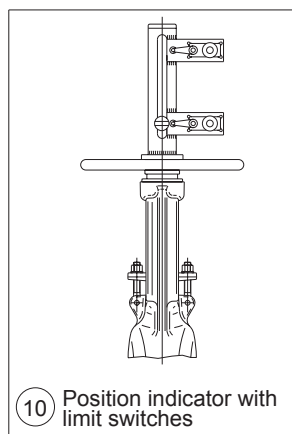

10 Position indicator with limit switches

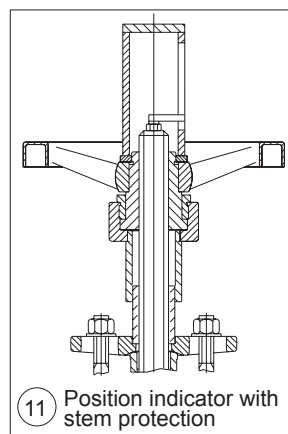

11 Position indicator with stem protection

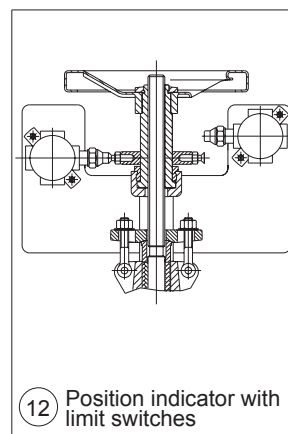

12 Position indicator with limit switches

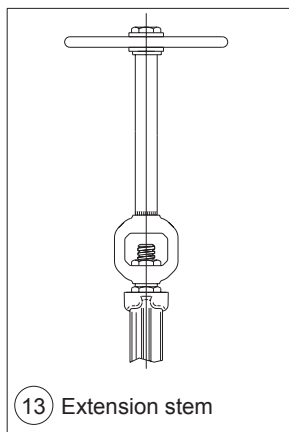

13 Extension stem

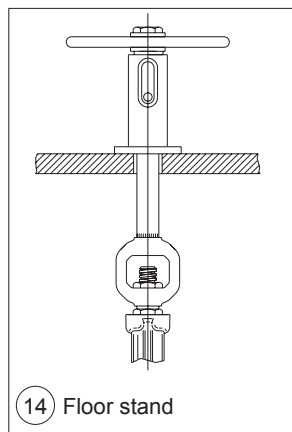

14 Floor stand

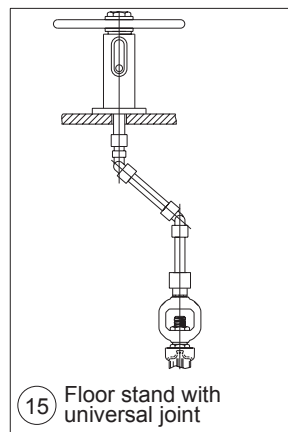

15 Floor stand with universal joint

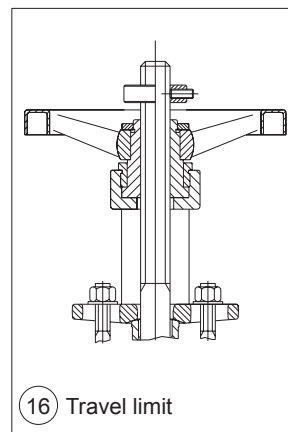

16 Travel limit

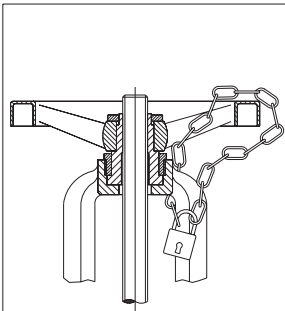

17 Locking device with padlock and chain

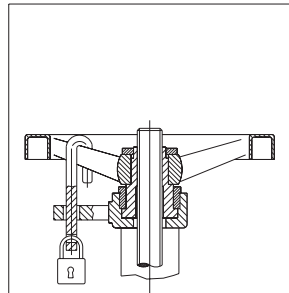

18 Locking system

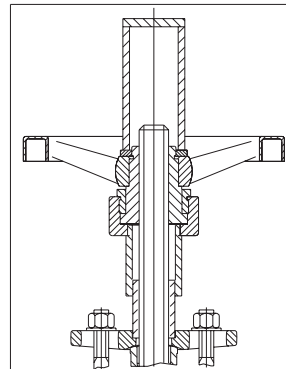

19 Stem protection

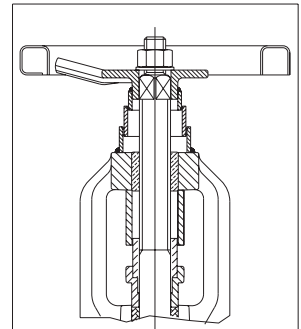

20 Stem protection for globe valve

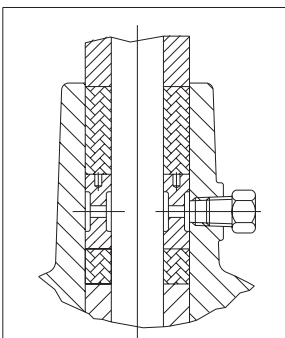

21 Lantern ring

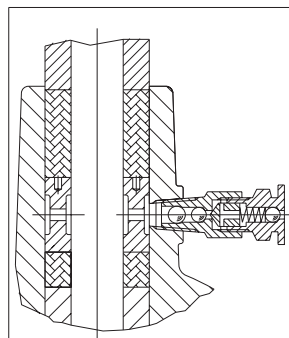

22 Lantern ring with double ball grease injector

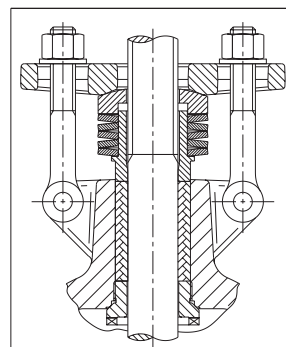

23 Spring loaded on stuffing box

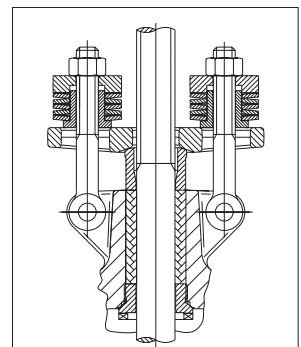

24 Spring loaded on eye bolts

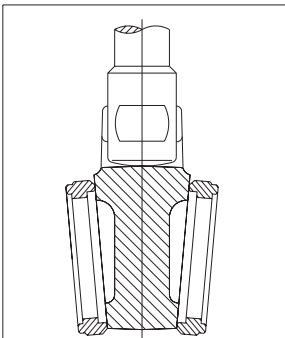

25 Solid wedge

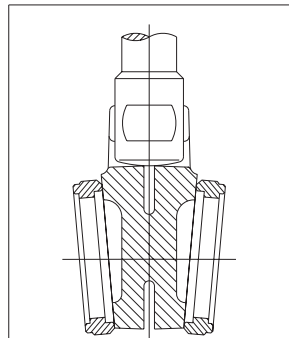

26 Flexible wedge

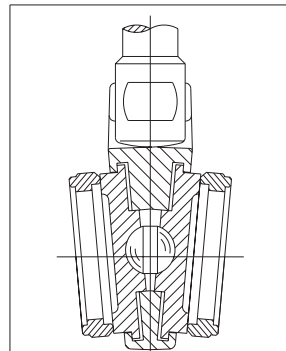

27 Split wedge

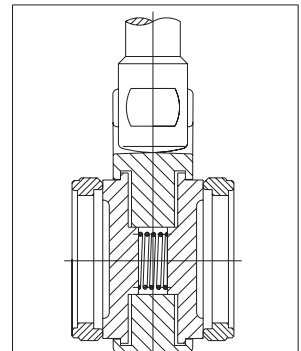

28 Parallel disk

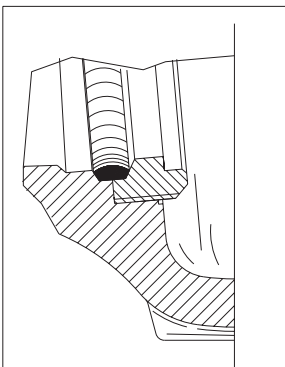

29 Welded seat ring

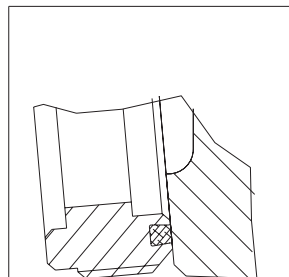

30 Soft seal on seat ring

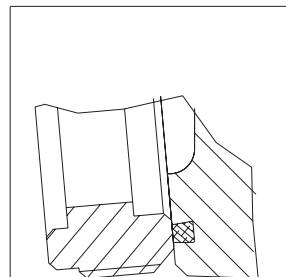

31 Soft seal on wedge

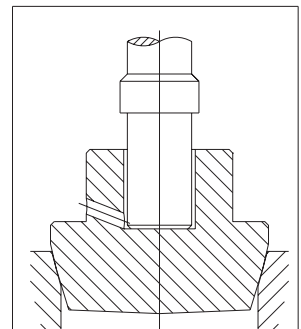

32 Stop check

INFORMACIÓN TÉCNICA

EJECUCIONES ESPECIALES (CONT.)

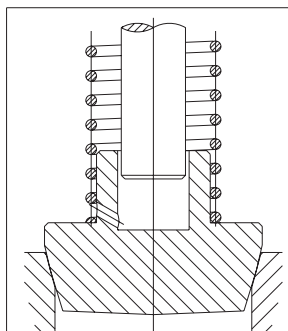

33 Stop check with spring

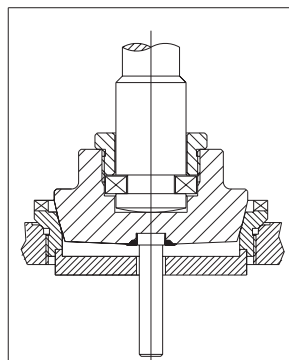

34 Guided disk

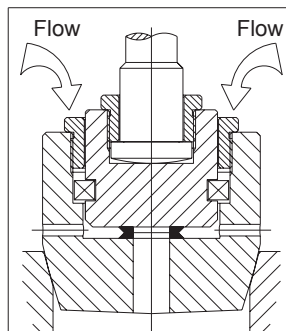

35 Double stage opening disk

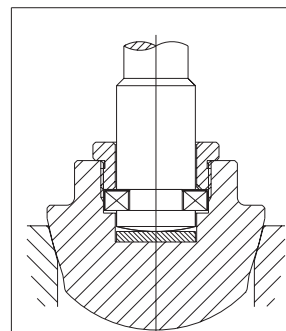

36 Parabolic / regulating disk

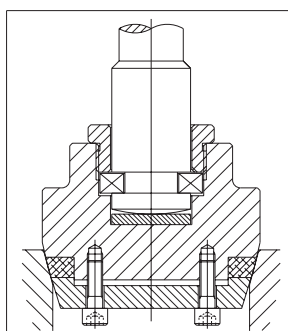

37 Soft seated disk

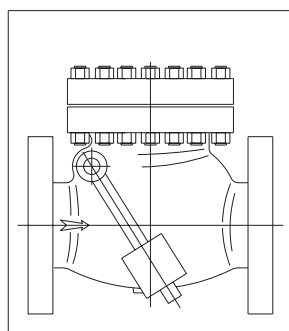

38 Swing check valve with outside lever and weight

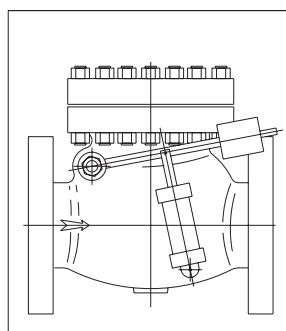

39 Swing check valve with shock absorber

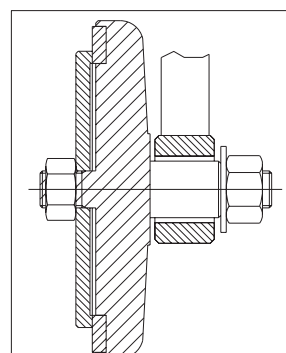

40 Soft seated disk for check valve

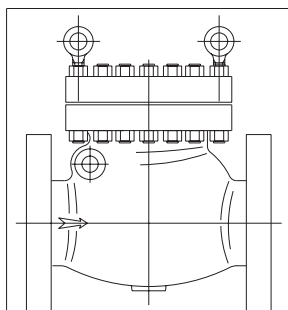

41 Swing check valve with lifting eyebolt

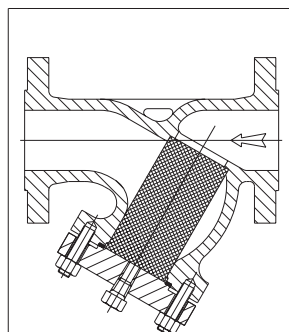

42 Strainer Y type with drain plug

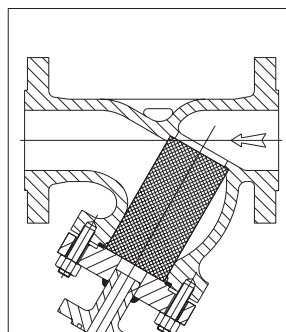

43 Strainer Y type with flange connection

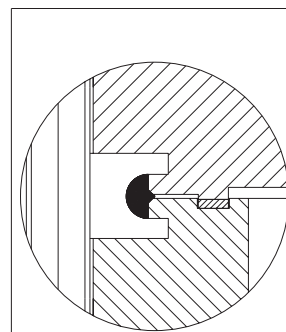

44 Body / bonnet seal weld

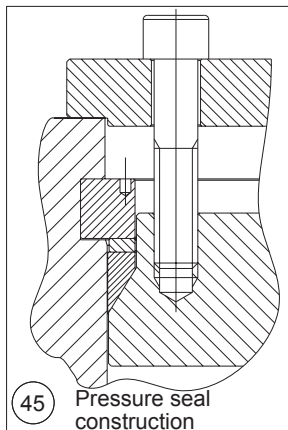

45 Pressure seal construction

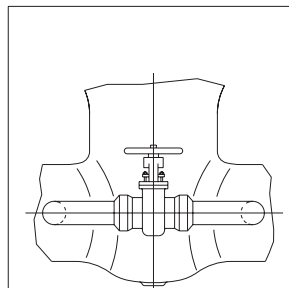

46 By pass (front view)

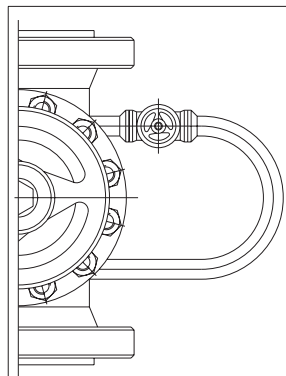

47 By pass (top view)

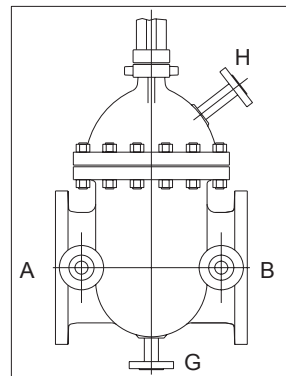

48 Flanges connection

CONEXIONES AUXILIARES

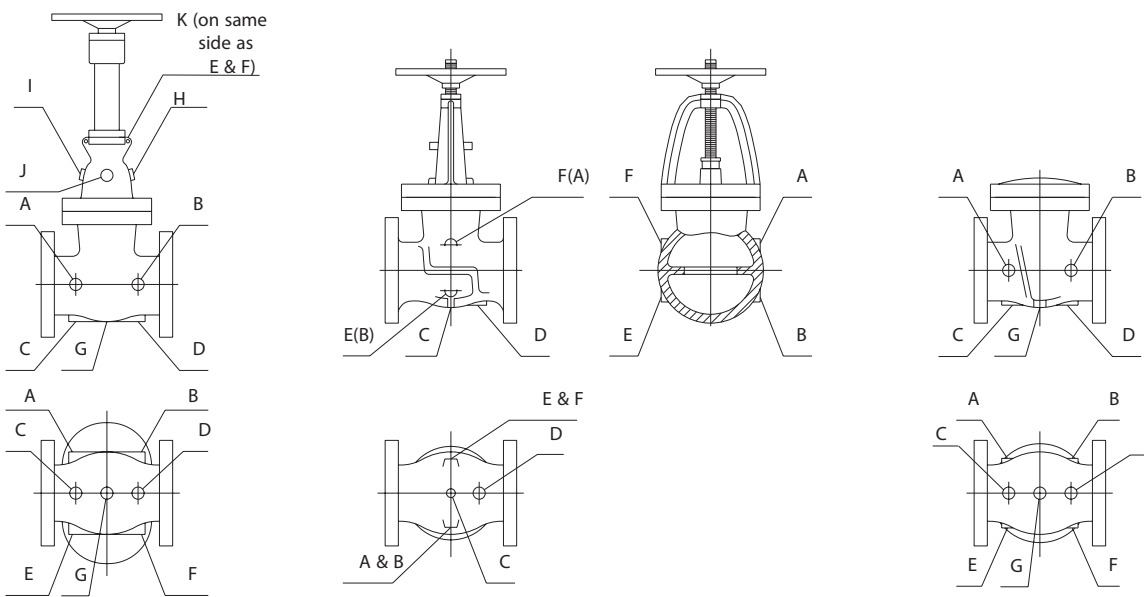

GATE VALVE **GLOBE VALVE** **CHECK VALVE**

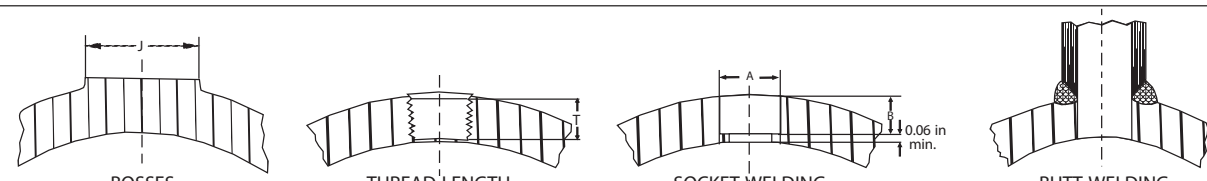

BOSSSES **THREAD LENGTH** **SOCKET WELDING** **BUTT WELDING**

Size of Valve	2" to 4"	5" to 8"	10" to 24"
Size of Connections	1/2"	3/4"	1"
Length of Thread T	14	14	18
Min.Diam. of Socket A	22	27	34
Min.Depth. of Socket B	5	6.5	6.5
Diameter of Boss J	38	44	54
Size of Tapping	1/2"	3/4"	1"

ROSCA NPT ESTÁNDAR - ASME B1.20.1

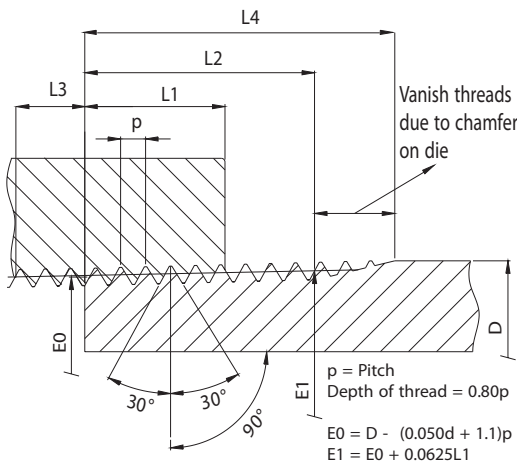

Vanish threads due to chamfer on die

$p = \text{Pitch}$
Depth of thread = $0.80p$

$E0 = D - (0.050d + 1.1)p$
 $E1 = E0 + 0.0625L1$
 $L2 = (0.80D + 6.8)p$

NOMINAL PIPE SIZE (INCH)	OUTSIDE DIAMETER OF PIPE	THREADS PER INCH	PITCH OF THREAD	HANDTIGHT ENGAGEMENT	LENGTH OF EFFECTIVE THREAD (EXTERNAL)	WRENCH MAKEUP LENGTH FOR INTERNAL THREAD	OVERALL LENGTH EXTERNAL THREAD	PITCH DIAM. AT BEGINNING OF EXTERNAL THREAD
DN	D	(n)	P	L1	L2	L3	L4	E0
1/8	10,29	27	0,940	4,572	6,703	2,822	9,967	9,233
1/4	13,72	18	1,412	5,080	10,206	4,234	15,103	12,126
3/8	17,14	18	1,412	6,096	10,358	4,234	15,255	15,545
1/2	21,34	14	1,814	8,128	13,556	5,443	19,850	19,263
3/4	26,67	14	1,814	8,611	13,861	5,443	20,155	24,58
1	33,40	11,5	2,210	10,160	17,343	6,627	25,006	30,825
1 1/4	42,16	11,5	2,210	10,668	17,953	6,627	25,616	39,55
1 1/2	48,26	11,5	2,210	10,668	18,377	6,627	26,040	45,621
2	60,32	11,5	2,210	11,074	19,215	6,627	26,878	57,633

INFORMACIÓN TÉCNICA

DIMENSIONES EXTREMOS PARA SOLDAR

BUTT WELDING ENDS - ASME B16.25

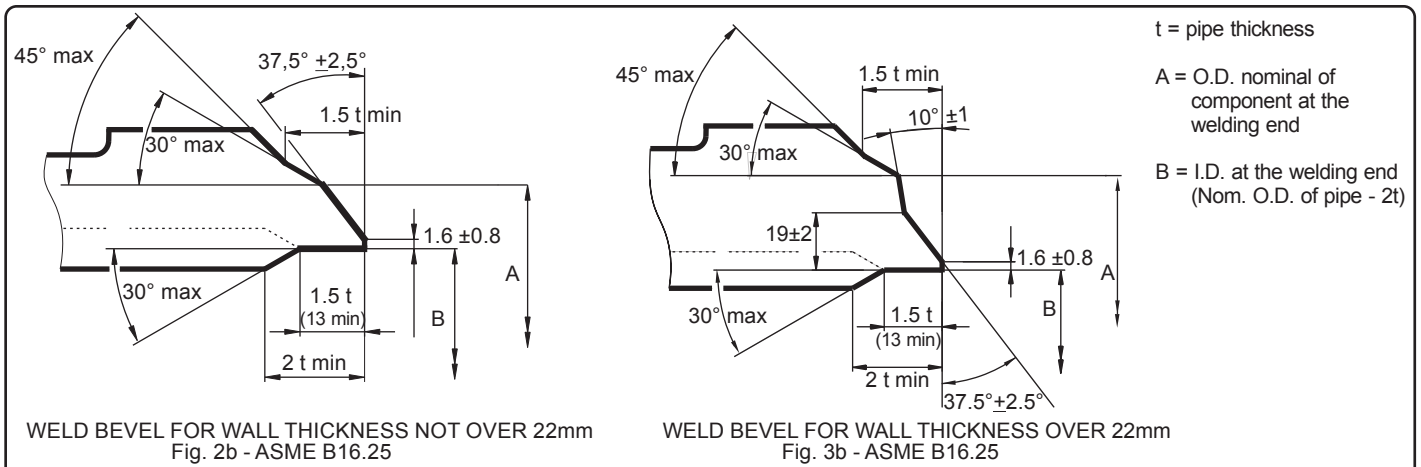

DN (inches)	Nom. pipe O.D.	A (1)	Wall thickness of pipe											
			sch. 20	sch. 30	sch. Std	sch. 40	sch. 60	sch. xs	sch. 80	sch100	sch120	sch140	sch160	schxxs
1" 1/2	48.3	n.a.			3.68	3.68		5.08	5.08				7.14	10.16
2"	60.3	n.a.			3.91	3.91		5.54	5.54				8.74	11.07
2" 1/2	73.0	75			5.16	5.16		7.01	7.01				9.52	14.02
3"	88.9	91			5.49	5.49		7.62	7.62				11.13	15.24
4"	114.3	117			6.02	6.02		8.56	8.56		11.13		13.49	17.12
5"	141.3	144			6.55	6.55		9.52	9.52		12.70		15.88	19.05
6"	168.3	172			7.11	7.11		10.97	10.97		14.27		18.26	21.95
8"	219.1	223	6.35	7.04	8.18	8.18	10.31	12.70	12.70	15.09	18.26	20.62	23.01	22.22
10"	273.0	278	6.35	7.80	9.27	9.27	12.70	12.70	15.09	18.26	21.44	25.40	28.58	25.40
12"	323.8	329	6.35	8.38	9.52	10.31	14.27	12.70	17.48	21.44	25.40	28.57	33.32	
14"	355.6	362	7.92	9.52	9.52	11.12	15.09	12.70	19.05	23.83	27.76	31.75	35.71	
16"	406.4	413	7.92	9.52	9.52	12.70	16.66	12.70	21.44	26.19	30.94	36.52	40.46	
18"	457.2	464	7.92	11.13	9.52	14.27	19.05	12.70	23.83	29.36	34.92	39.67	45.24	
20"	508.0	516	9.52	12.70	9.52	15.06	20.62	12.70	26.19	32.54	38.10	44.45	49.99	
24"	609.6	619	9.52	14.27	9.52	17.45	24.59	12.70	30.94	38.89	46.02	52.37	59.51	

(1) The diameters listed are not requirements

SOCKET WELDING ENDS - ASME B16.11

DN mm	Nominal pipe size (inches)	B mm (min.)	J mm (min.)	Class 3000 Sch. 80		Class 6000 Sch. 160		Class 9000 Wall Des. XXS	
				C mm (min.)	D mm (min.)	C mm (min.)	D mm (min.)	C mm (min.)	D mm (min.)
6	1/8"	10,8	9,5	3,18	6,1	3,43	3,2	--	--
8	1/4"	14,2	9,5	3,30	8,5	4,01	5,6	--	--
10	3/8"	17,6	9,5	3,50	11,8	4,37	8,4	--	--
15	1/2"	21,8	9,5	4,09	15,0	5,18	11,0	5,94	5,6
20	3/4"	27,2	12,5	4,27	20,2	6,04	14,8	6,93	10,3
25	1"	33,9	12,5	4,98	25,9	6,93	19,9	7,95	14,4
32	1" 1/4	42,7	12,5	5,28	34,3	9,93	28,7	7,95	22,0
40	1" 1/2	48,8	12,5	5,54	40,1	7,80	33,2	8,91	27,2
50	2"	61,2	16,0	6,04	51,7	9,50	42,1	10,89	37,4
65	2" 1/2	73,9	16,0	7,67	61,2	--	--	--	--
80	3"	89,8	16,0	8,30	76,4	--	--	--	--
100	4"	115,2	16,0	9,35	100,7	--	--	--	--

INFORMACIÓN TÉCNICA

DIMENSIONES BRIDAS ASME B16.47 & MSS SP-44

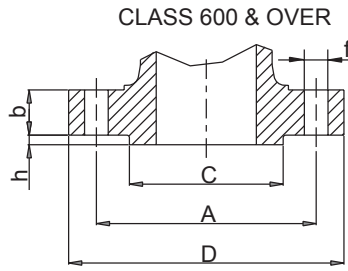
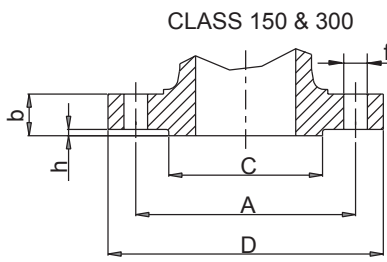

DN = Nominal pipe size (inches)
D = Outside diameter of flange
b* = Thickness of flange min.
C = Diameter of hub
h = Height of raised face
N = Number of bolt holes
f = Diameter of bolt holes
A = Diameter of bolt circle
RJ = Groove number

* raised face included for ANSI Class 150-300
raised face not included for ANSI Class 600-900

CLASS	DN	D	b	C	h	N	f	A	R	CLASS	DN	D	b	C	h	N	f	A	RJ
150	26"	870	68,3	749	1,6	24	35,1	806		150	38"	1238	87,4	1073	1,6	32	41,1	1149	
300	26"	972	79,2	749	1,6	28	44,5	876	93	300	38"	1168	108,0	1029	1,6	32	41,1	1092	
600	26"	1016	108,0	749	1,6	28	50,8	914	93	600	38"	1270	152,4	1054	1,6	28	60,5	1162	
900	26"	1086	139,7	953	1,6	20	73,2	953	100	900	38"	1461	190,5	1289	1,6	20	91,9	1289	
150	28"	927	71,4	800	1,6	28	35,1	864		150	40"	1289	90,4	1124	1,6	36	41,1	1200	
300	28"	1035	85,9	800	1,6	28	44,5	940	94	300	40"	1238	114,3	1086	1,6	32	44,5	1156	
600	28"	1073	111,3	800	1,6	28	53,8	965	94	600	40"	1321	158,8	1111	1,6	32	60,5	1213	
900	28"	1168	142,7	1022	1,6	20	79,2	1022	101	900	40"	1511	196,9	1340	1,6	24	91,9	1340	
150	30"	984	74,7	857	1,6	28	35,1	914		150	42"	1346	96,8	1194	1,6	36	41,1	1257	
300	30"	1092	91,9	857	1,6	28	47,8	997	95	300	42"	1289	119,1	1137	1,6	32	44,5	1207	
600	30"	1130	114,3	857	1,6	28	53,8	1022	95	600	42"	1403	168,1	1168	1,6	28	66,5	1283	
900	30"	1232	149,4	1086	1,6	20	79,2	1086	102	900	42"	1562	206,2	1391	1,6	24	91,9	1391	
150	32"	1060	81,0	914	1,6	28	41,1	978		150	44"	1403	101,6	1245	1,6	40	41,1	1314	
300	32"	1149	98,6	914	1,6	28	50,8	1054	96	300	44"	1353	124,0	1194	1,6	32	47,8	1264	
600	32"	1194	117,3	914	1,6	28	60,5	1080	96	600	44"	1454	173,0	1226	1,6	32	66,5	1334	
900	32"	1314	158,8	1156	1,6	20	85,9	1156	103	900	44"	1648	214,4	1464	1,6	24	98,6	1464	
150	34"	1111	82,6	965	1,6	32	41,1	1029		150	46"	1454	103,1	1295	1,6	40	41,1	1365	
300	34"	1207	101,6	965	1,6	28	50,8	1105	97	300	46"	1416	128,5	1245	1,6	28	50,8	1321	
600	34"	1245	120,7	965	1,6	28	60,5	1130	97	600	46"	1511	179,3	1276	1,6	32	66,5	1391	
900	34"	1397	165,1	1226	1,6	20	91,9	1226	104	900	46"	1734	225,6	1537	1,6	24	105	1537	
150	36"	1168	90,4	1022	1,6	32	41,1	1086		150	48"	1511	108,0	1359	1,6	44	41,1	1422	
300	36"	1270	104,6	1022	1,6	32	53,8	1168	98	300	48"	1467	133,4	1302	1,6	32	50,8	1372	
600	36"	1314	124,0	1022	1,6	28	66,5	1194	98	600	48"	1594	189,0	1334	1,6	32	73,2	1461	
900	36"	1461	171,5	1289	1,6	20	91,9	1289	105	900	48"	1784	233,4	1588	1,6	24	105	1588	

FLANGES FACING FINISH

NOMINAL ROUGHNESS GRADES (R_a) FOR
ROUGHNESS COMPARISON SPECIMENS - ASME B46.1

µm	µin.
0.006	0.25
0.0125	0.5
0.025	1
0.05	2
0.1	4
0.2	8
0.4	16
0.8	32
1.6	63
3.2	125
6.3	250
12.5	500
25	1,000
50	2,000
100	4,000
200	8,000
400	16,000

ASME B16.5

TONGUE AND GROOVE - SMALL MALE AND FEMALE

The gasket contact surface shall not exceed 125 microinches (3,2 micrometers) roughness.

RING JOINT

The side wall surface of gasket groove shall not exceed 63 microinches (1,6 micrometers) roughness.

OTHER FLANGE FACINGS

Either a serrated concentric or serrated spiral finish having a resultant surface finish from 125 microinches to 250 microinches (3,2 to 6,3 micrometers) average roughness.

MSS SP-6 - steel

FLAT OR 1/6" (1.6 mm) RAISED FACE AND 1/4" (6.4 mm) RAISED AND LARGE MALE & FEMALE

Serrated: spiral or concentric, 45 to 55 per inch (18 to 21 per cm). Surface finish shall have a 125 to 250 microinches (3.2 to 6.3 micrometers) Ra.

SMALL MALE & FEMALE, LARGE & SMALL TONGUE & GROOVE

Serrated (as above) or non-serrated: 125 microinches (3,2 micrometers) Ra max.

RING JOINT

Non-serrated: 63 microinches (1.6 micrometers) Ra max. according to ASME B46.1.

The finish of contact faces of pipe flanges and connecting end flanges of fittings shall be judged by visual comparison with Ra standards.

INFORMACIÓN TÉCNICA

DIMENSIONES BRIDAS DIN DN350 - 1200

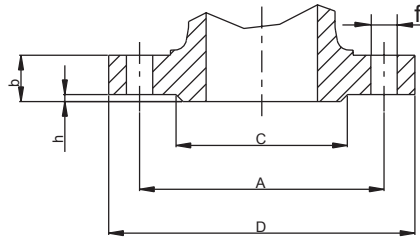

DN = Nominal pipe size
 D = Outside diameter of flange
 b = Thickness of flange min.
 C = Diameter of hub
 h = Height of raised face
 N = Number of bolt holes
 f = Diameter of bolt holes
 A = Diameter of bolt circle

PN	DN	D	b	C	h	N°	f		PN	DN	D	b	C	h	N°	f	A
6	350	490	22	415	4	12	22	445	6	700	860	24	775	5	24	25	810
10	350	505	26	430	4	16	22	460	10	700	895	30	800	5	24	30	840
16	350	520	30	438	4	16	26	470	16	700	910	42	795	5	24	36	840
25	350	555	38	450	4	16	33	490	25	700	960	50	820	5	24	42	875
40	350	580	46	465	4	16	36	510	40	700	995	64	840	5	24	48	900
64	350	600	56	465	4	16	39	525	64	700	1045	84	840	5	24	56	935
100	350	655	74	465	4	16	48	560	100	700	1145	120	840	5	24	70	1020
6	400	540	22	465	4	16	22	495	6	800	975	24	880	5	24	30	920
10	400	565	26	482	4	16	26	515	10	800	1015	32	905	5	24	33	950
16	400	580	32	490	4	16	30	525	16	800	1025	42	900	5	24	39	950
25	400	620	40	505	4	16	36	550	25	800	1085	64	930	5	24	48	990
40	400	660	50	535	4	16	39	585	40	800	1165	72	960	5	24	62	1050
64	400	670	60	535	4	16	42	585	64	800	1165	92	960	5	24	62	1050
100	400	715	78	535	4	16	48	620	100	800	n.a	n.a	n.a	n.a	n.a	n.a	n.a
6	450	595	22	520	4	16	22	550	6	900	1075	26	980	5	24	30	1020
10	450	615	26	532	4	20	26	565	10	900	1115	34	1005	5	28	33	1050
16	450	640	32	550	4	20	30	585	16	900	1125	44	1000	5	28	39	1050
25	450	670	40	555	4	20	36	600	25	900	1185	68	1030	5	28	48	1090
40	450	685	50	560	4	20	39	610	40	900	1250	78	1070	5	28	56	1140
64	450	715	64	560	4	20	42	630	64	900	1285	98	1070	5	28	62	1170
100	450	770	86	560	4	20	48	675	100	900	n.a	n.a	n.a	n.a	n.a	n.a	n.a
6	500	645	24	570	4	20	22	600	6	1000	1175	26	1080	5	28	30	1120
10	500	670	28	585	4	20	26	620	10	1000	1230	34	1110	5	28	36	1160
16	500	715	36	610	4	20	33	650	16	1000	1255	46	1115	5	28	42	1170
25	500	730	44	615	4	20	36	660	25	1000	1320	62	1140	5	28	56	1210
40	500	755	52	615	4	20	42	670	40	1000	1360	80	1180	5	28	56	1250
64	500	800	68	615	4	20	48	705	64	1000	1415	108	1180	5	28	70	1290
100	500	870	94	615	4	20	56	760	100	1000	n.a	n.a	n.a	n.a	n.a	n.a	n.a
6	600	755	24	670	5	20	26	705	6	1200	1405	28	1295	5	32	33	1340
10	600	780	28	685	5	20	30	725	10	1200	1455	38	1330	5	32	39	1380
16	600	840	40	725	5	20	36	770	16	1200	1485	52	1330	5	32	48	1390
25	600	845	46	720	5	20	39	770	25	1200	1530	70	1350	5	32	56	1420
40	600	890	54	735	5	20	48	795	40	1200	1575	88	1380	5	32	62	1460
64	600	930	76	735	5	20	56	820	64	1200	1665	126	1380	5	32	78	1530
100	600	990	104	735	5	20	62	875	100	1200	n.a	n.a	n.a	n.a	n.a	n.a	n.a

FLANGES - TYPE OF CONTACT SURFACES AS PER DIN 2526



Type A - Contact face without stipulation

Type B - Contact face $R_z = 160$, turned (not finer than 40 micron)

Type C - Raised face $R_z = 160$ (not finer than 40 micron), turned

Type D - Raised face $R_z = 40$, turned

Type E - Raised face $R_z = 16$, turned

NOMINAL ROUGHNESS GRADES (R_a)

R_a (μm)	R_z (μm)
1.6	16
3.2	25
6.3	40
12.5	100
25	160

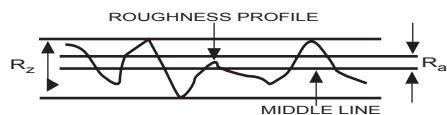

ACABADO SUPERFICIES BRIDAS - DIN 2526

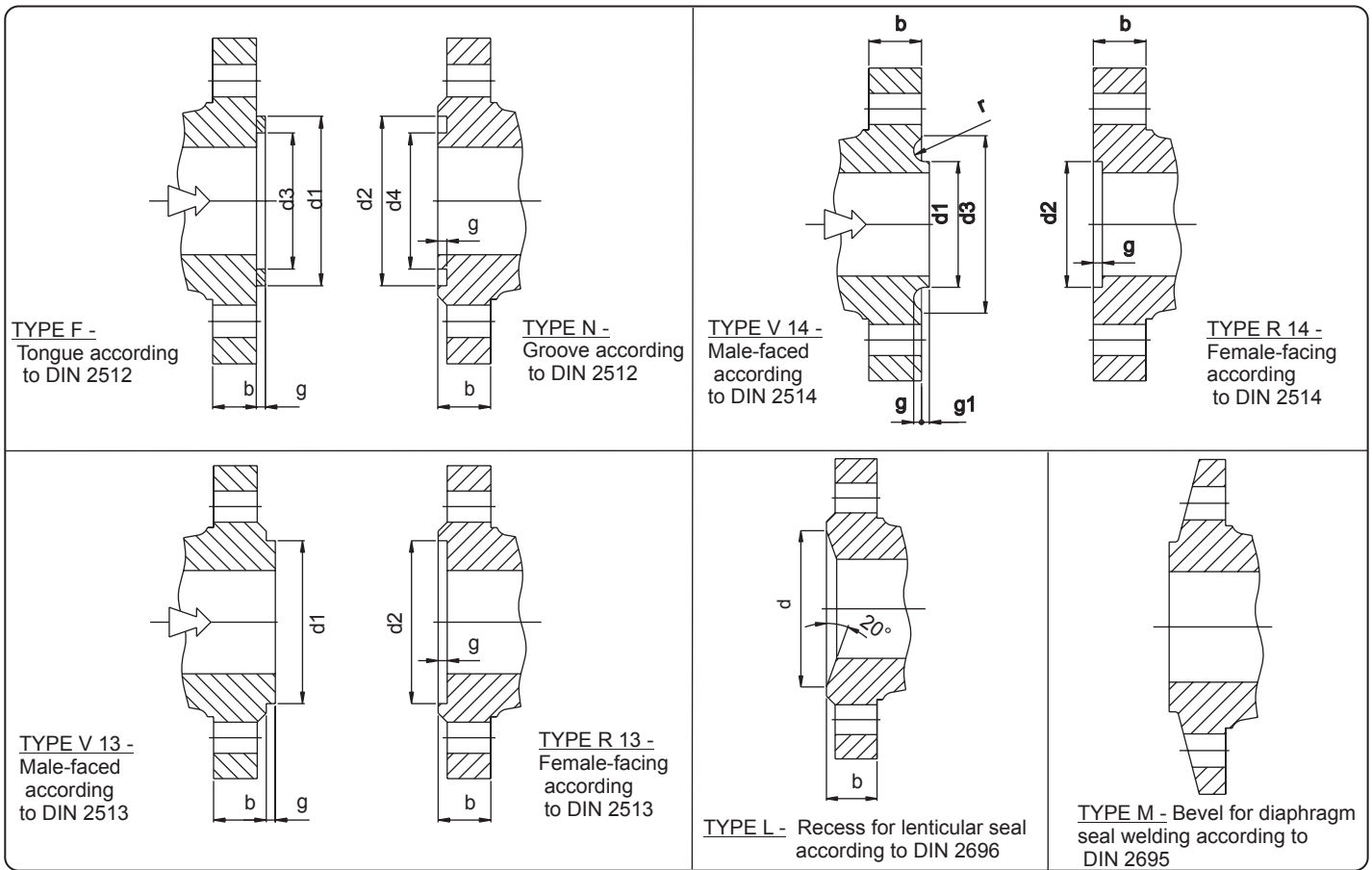

DIMENSIONS OF FACING

DN	DIN 2513					DIN 2512									DN	DIN 2514							LENTICULAR SEAL DIN 2696		DN
	PN ≤ 6		PN ≥ 10			g	PN ≤ 6				PN ≥ 10					g	PN 10 ÷ 40						PN 64 : 250		
	d ₁	d ₂	d ₁	d ₂	d ₃		d ₄	d ₁	d ₂	d ₃	d ₄	d ₁	d ₂	d ₃			g	g ₁	r	d					
10	30	31	34	35	4	30	31	22	21	34	35	24	23	4	10	-	-	-	-	-	-	18	10		
15	35	36	39	40	4	35	36	27	26	39	40	29	28	4	15	-	-	-	-	-	-	24	15		
20	42	43	50	51	4	42	43	32	31	50	51	36	35	4	20	35	36	51	4	2	2,5	30	20		
25	49	50	57	58	4	49	50	39	38	57	58	43	42	4	25	42	43	58	4	2	2,5	35	25		
32	61	62	65	66	4	61	62	49	48	65	66	51	50	4	32	50	51	66	4	2	2,5	43	32		
40	68	69	75	76	4	68	69	56	55	75	76	61	60	4	40	60	61	76	4	2	2,5	51	40		
50	81	82	87	88	4	81	82	69	68	87	88	73	72	4	50	72	73	88	4	2	2,5	63	50		
65	101	102	109	110	4	101	102	89	88	109	110	95	94	4	65	94	95	110	4	2	2,5	85	65		
80	117	118	120	121	4	117	118	103	102	120	121	106	105	4	80	105	106	121	4	2	2,5	97	80		
100	137	138	149	150	4,5	137	138	123	122	149	150	129	128	4,5	100	128	129	150	4,5	2,5	3	124	100		
125	165	166	175	176	4,5	165	166	149	148	175	176	155	154	4,5	125	154	155	176	4,5	2,5	3	153	125		
150	192	193	203	204	4,5	192	193	176	175	203	204	183	182	4,5	150	182	183	204	4,5	2,5	3	181	150		
175	222	223	233	234	4,5	222	223	206	205	233	234	213	212	4,5	175	212	213	234	4,5	2,5	3	218	175		
200	249	250	259	260	4,5	249	250	231	230	259	260	239	238	4,5	200	238	239	260	4,5	2,5	3	243	200		
250	304	305	312	313	4,5	304	305	286	285	312	313	292	291	4,5	250	291	292	313	4,5	2,5	3	298	250		
300	354	355	363	364	4,5	354	355	336	335	363	364	343	342	4,5	300	342	343	364	4,5	2,5	3	345	300		
350	401	402	421	422	5	401	402	381	380	421	422	395	394	5	350	394	395	422	5	3	3,5	394	350		
400	451	452	473	474	5	451	452	431	430	473	474	447	446	5	400	446	447	474	5	3	3,5	445	400		
450	505	506	523	524	5	505	506	481	480	523	524	497	496	5	450	496	497	524	5	3	3,5		450		
500	555	556	575	576	5	555	556	531	530	575	576	549	548	5	500	548	549	576	5	3	3,5		500		
600	655	656	675	676	5	655	656	631	630	675	676	649	648	5	600	648	649	676	5	3	3,5		600		
700	760	761	777	778	5	760	761	736	735	777	778	751	750	5	700	750	751	778	5	3	3,5		700		
800	865	866	882	883	5	865	866	841	840	882	883	856	855	5	800	855	856	883	5	3	3,5		800		
900	965	966	987	988	5	965	966	941	940	987	988	961	960	5	900	960	961	988	5	3	3,5		900		
1000	1062	1063	1091	1092	6	1062	1063	1036	1035	1091	1092	1061	1060	6	1000	1060	1061	1092	6	3	4		1000		

INFORMACIÓN TÉCNICA

ABREVIATURAS TÉCNICAS

Abreviaturas técnicas		
Clave	Denominación	Equivalencia
F6	Asiento y cierre sin estrellitar (*)	Trim 1
F6 XU	Asiento estrellitado	Trim 8 o HFS
F6 U	Asiento y cierre estrellitados	Trim 5 o HF
OS & Y	Husillo ascendente (Outscrew & yoke)	
B.B.	Unión cuerpo-tapa atornillada (Bolted bonnet)	
W.B.	Unión cuerpo-tapa soldada (Welded bonnet)	
F.B.	Paso total (Full bore)	
R.B.	Paso reducido (Reduced bore)	
#	Libras	

En la tabla anterior podemos encontrar la numeración correspondiente a los internos (o **Trim**) en la manera en que se les conoce según la norma **API 600** para válvulas ANSI. Nos será de gran utilidad puesto que se utilizan en las descripciones de válvulas para la industria del petróleo, tanto en la solicitud de oferta como en las especificaciones/requisiciones de las ingenierías.

(*) **Stellite**: Aportación de material de gran dureza en los asientos con el fin de evitar su desgaste.

(**) **HF**: Hard Face (cara dura).

Ejemplo: **V. COMP. 800# OS&Y R.B. A-105/F6U B.B. NPT-H x SW 1/2"**

Válvula de compuerta de Rating 800 libras, de Husillo exterior ascendente, Paso reducido, material del cuerpo en Acero forjado calidad A-105 con los internos en Acero inoxidable con aportación de stellite tanto en la cuña como en los asientos; con la conexión cuerpo-tapa atornillada, extremos por uno de los lados de la válvula roscada NPT hembra y por el otro para soldar a tubería Socket weld, diámetro de paso 1/2 pulgada.

ESPECIFICACIONES DEL TRIM

MATERIALES DEL TRIM SEGÚN API 600

TRIM					
Trim nº	Equivalencia	Nominal trim	Cara de asiento	Internos	Servicio
1		F6	13Cr	13Cr	Para servicios generales erosivos o no corrosivos entre -100°C y 400°C
2		304	18Cr-8Ni	18Cr-8Ni	Para moderada presión en servicio no erosivo. Servicio corrosivo entre -265°C y 320°C
3		F310	25Cr-20Ni	25Cr-20Ni	Para moderada presión en servicio no erosivo. Servicio corrosivo entre -265°C y 450°C
4		Hard F6	Hard 13Cr	13Cr	Igual servicio del TRIM 1 pero para media presión
5	U	Hardfaced	Co-Cr A	13Cr	Para servicio de alta presión, baja erosión y corrosión entre -265°C y 650°C
5A		Hardfaced	Ni-Cr	13Cr	Igual servicio del TRIM 5 donde el Co no es permitido
6		F6 and Cu-Ni	F6 and Cu-Ni	13Cr	Igual servicio del TRIM 1
7		F6 and Hard F6	13Cr and Hard 13Cr	13Cr	Igual servicio del TRIM 1 pero para presión moderada
8	XU	F6 and Hardfaced	13Cr Co-Cr A	13Cr	Igual servicio del TRIM 5 pero para presión moderada
8A		F6 and Hardfaced	13Cr Ni-Cr	13Cr	Igual servicio del TRIM 5-A pero para presión moderada
9		Monel	Ni-Cu alloy	Ni-Cu alloy	Para fluidos muy corrosivos. Servicio erosivo y corrosivo entre -240°C y 480°C
10		316	18Cr-8Ni	18Cr-8Ni	Igual servicio del TRIM 2
11		Monel and Hardfaced	Ni-Cu alloy Trim 5 o 5A	Ni-Cu alloy	Igual servicio del TRIM 9 pero para presión media
12	316 XU	316 and Hardfaced	18Cr-8Ni Trim 5 o 5A	18Cr-8Ni	Igual servicio del TRIM 10 pero para presión media
13		Alloy 20	19Cr-29Ni	19Cr-29Ni	Servicio muy corrosivo para presión moderada entre -45°C y 320°C
14		Alloy 20 and Hardfaced	19Cr-29Ni Trim 5 o 5A	19Cr-29Ni	Igual servicio del TRIM 13 pero para presión media
15		Hardfaced	Co-Cr A	18Cr-8Ni	
16	316 U	Hardfaced	Co-Cr A	18Cr-8Ni	
17		Hardfaced	Co-Cr A	18Cr-10Ni	
18		Hardfaced	Co-Cr A	19Cr-29Ni	

INFORMACIÓN TÉCNICA

TABLAS DE CONVERSIÓN

TABLAS DE EQUIVALENCIA DE MATERIALES

EQUIVALENCIA DE MATERIALES				
ASTM	BS	DIN	AFNOR	MARCA REG.
A216 WCB	161-480	GS-CK25	A480 CP-M	-
A217 C1	240	GS-22 Mo 4	20 Mn 5-M	-
A217 WC6	621	GS-17 Cr Mo 55	15CD5,05M	-
A217 WC9	622	GS-12 Cr Mo 19	15CD9,10M	-
A217 C5	625	GS-12 Cr Mo 19,5	Z15CD5,05M	-
A217 C12	629	G-X12 Cr Mo 101	-	-
A351 CF3	304 C12	G-X2 Cr Ni 18.9	Z2CN1810M	-
A351 CF3M	316 C12	G-X2 Cr Ni Mo 1810	Z2CN18,12M	-
A351 CF8	304 C15	G-X6 Cr Ni 18.9	Z6CN18,10M	-
A351 CF8C	-	-	-	-
A351 CF8M	315-C16	G-X Cr Ni Mo 18.10	Z6CN18,12M	-
A351 CN7M	332 C11	G-X Ni Cr Mo Cu Nb 25.20	Z6NCU252004M	-
A494 N-12MV	-	Ni Mo 30	-	Hastelloy B
A494 CW-12MW	-	Ni Mo 16 GW	-	Hastelloy C
A494 M35-1	NA13	Ni Cu 30 Fe	-	Monel 400
A494 CW-6MC	-	Ni Cr 22 Mo 9 Nb	-	Inconel 625
-	Na 16	Ni Cr 21 Mo	-	Incoloy 825
-	-	X2 Cr Ni Mo N 2253	-	SAF 2205
-	-	X1 Ni Cr Mo Cu N 25206	-	254 SMO
-	-	-	-	Ferrallium 255
A352 LCB	161-480	GS-CK24	-	-
A352 LC3	503-LT60	GS-10 Ni 14	-	-

EQUIVALENCIA DE MATERIALES ESTÁNDAR				
FUNDICIÓN	FORJA	LAMINADO	BARRA	TUBERÍA
A216 WCB	A105	A516 GR.70	A105	A106 GR.B
A217 WC1	A182 F1	A204 GR.A	-	A335 P1
A217 WC6	A182 F11	A387 GR.11	A739 B11	A335P11
A217 WC9	A182 F22	A387 GR.22	A739 B22	A335 P22
A217 C5	A182 F5	A387 GR.5	A182 F5	A335 P5
A217 C12	A182 F9	A387 GR.9	A182 F9	A395 P9
A217 CA15	A182 F6	A240 TP 410	A479 TP 410	-
A352 LCB	A350 LF2	A516 GR.70	A696 GR.C	A333 GR.6
A352 LC2	-	A203 GR.B	-	A333 GR.7
A352 LC3	A350 LF3	A203 GR.E	-	A333 GR.3
A351 CF3	A182 F304L	A240 TP 340L	A479 TP 304L	A312 TP 304L
A351 CF3M	A182 F316L	A240 TP 316L	A479 TP 316L	A312 TP 316L
A351 CF8	A182 F304	A240 TP 304	A479 TP 304	A312 TP 304
A351 CF8C	A182 F347	A240 TP 347	A479 TP 347	A312 TP 347
A351 CF8M	A182 F316	A240 TP 316	A479 TP 316	A312 TP 316

TABLAS DE CONVERSIÓN DE UNIDADES

PRESIÓN							
Bar	mbar	Pa (N/m ²)	Mpa	atm	mm Hg (Torr)	Kg/cm ²	p.s.i.
1	1.000	1 x 10 ⁵	0,1	0,987	750,062	1,02	14,504
0,001	1	100	0,000	0,001	0,750	0,001	0,015
0,000	0,01	1	0,000	0,000	0,008	0,000	0,000
10	1 x 10 ⁴	1 x 10 ⁶	1	9,870	7.500	10,2	145
1,013	1.013,25	101.325	0,101	1	760	1,033	14,696
0,001	1,333	133,322	0,000	0,001	1	0,001	0,019
0,981	980,665	98.100	0,098	0,968	735,560	1	14,223
0,069	68,948	6.894,760	0,007	0,068	51,715	0,07	1

TEMPERATURA			
°C	°F	°K	°R
1	33,8	274,15	492,6
-17,2	1	256,15	460,6
-272	-457,6	1	2,69
-272	-457,6	1,15	1

°Kelvin (K) = °C + 273,15 °Rankine (R) = °F + 459,69

LONGITUD	
Sist. Métrico	Sist. Imperial
1 mm	0.0394 pulgadas
1 cm	0.3937 pulgadas
1 m	1.0936 yardas
1 km	0.6214 millas

LONGITUD	
Sist. Imperial	Sist. Métrico
1 pulgada	2.54 cm
1 pie	0.3048 m
1 yarda	0.9144 m
1 milla	1.6093 km

VOLUMEN	
Sist. Métrico	Sist. Imperial
1 cm ³	0.0610 in ³
1 dm ³	0.0353 ft ³
1 m ³	1.3080 yd ³
1 l	1.76 pintas
1 hectolitro	21.997 galones

VOLUMEN	
Sist. Imperial	Sist. Métrico
1 in ³	16.387 cm ³
1 ft ³	0.0283 m ³
1 onza	28.413 ml
1 pinta	0.5683 l
1 galón	4.5461 l

INFORMACIÓN TÉCNICA

TABLAS DE CONVERSIÓN

TABLAS DE CONVERSIÓN - Pulgadas a milímetros

Pulgadas -> mm							
Pulgadas	mm	Pulgadas	mm	Pulgadas	mm	Pulgadas	mm
1/64	0.0156	17/64	0.2656	33/64	0.5156	49/64	0.7656
1/32	0.0312	9/32	0.2812	17/32	0.5312	25/32	0.7812
3/64	0.0469	19/64	0.2969	35/64	0.5469	51/64	0.7969
1/16	0.0625	5/16	0.3125	9/16	0.5625	13/16	0.8125
5/64	0.0781	21/64	0.3281	37/64	0.5781	53/64	0.8281
3/32	0.0937	11/32	0.3437	19/32	0.5937	27/32	0.8437
7/64	0.1094	23/64	0.3594	39/64	0.6094	55/64	0.8594
1/8	0.1250	3/8	0.3750	5/8	0.6250	7/8	0.8750
9/64	0.1406	25/64	0.3906	41/64	0.6406	57/64	0.8906
5/32	0.1562	13/32	0.4062	21/32	0.6562	29/32	0.9062
11/64	0.1719	27/64	0.4219	43/64	0.6719	59/64	0.9219
3/16	0.1875	7/16	0.4375	11/16	0.6875	15/16	0.9375
13/64	0.2031	29/64	0.4531	45/64	0.7031	61/64	0.9531
7/32	0.2187	15/32	0.4687	23/32	0.7187	31/32	0.9687
15/64	0.2344	31/64	0.4844	47/64	0.7344	63/64	0.9844
1/4	0.2500	1/2	0.5000	3/4	0.7500	1	1.0000

TABLAS DE CONVERSIÓN - Milímetros a pulgadas

mm -> Pulgadas													
mm	Pulgadas	mm	Pulgadas	mm	Pulgadas	mm	Pulgadas	mm	Pulgadas	mm	Pulgadas	mm	Pulgadas
1	0,03937	17	0,66929	33	1,29921	49	1,92913	65	2,55906	81	3,18898	103	4,05512
2	0,07874	18	0,70866	34	1,33858	50	1,96850	66	2,59843	82	3,22835	104	4,09449
3	0,11811	19	0,74803	35	1,37795	51	2,00787	67	2,63780	83	3,26772	105	4,13386
4	0,15748	20	0,78740	36	1,41732	52	2,04724	68	2,67717	84	3,30709	106	4,17323
5	0,19685	21	0,82677	37	1,45669	53	2,08661	69	2,71654	85	3,34646	107	4,21260
6	0,23622	22	0,86614	38	1,49606	54	2,12598	70	2,75591	86	3,38583	108	4,25197
7	0,27559	23	0,90551	39	1,53543	55	2,16535	71	2,79528	87	3,42520	109	4,29134
8	0,31496	24	0,94488	40	1,57480	56	2,20472	72	2,83465	88	3,46457	110	4,33071
9	0,35433	25	0,98425	41	1,61417	57	2,24409	73	2,87402	89	3,50394	111	4,37008
10	0,39370	26	1,02362	42	1,65354	58	2,28346	74	2,91339	90	3,54331	112	4,40945
11	0,43307	27	1,06299	43	1,69291	59	2,32283	75	2,95276	91	3,58268	113	4,44882
12	0,47244	28	1,10236	44	1,73228	60	2,36220	76	2,99213	92	3,62205	114	4,48819
13	0,51181	29	1,14173	45	1,77165	61	2,40157	77	3,03150	93	3,66142	115	4,52756
14	0,55118	30	1,18110	46	1,81102	62	2,44094	78	3,07087	94	3,70079	116	4,56693
15	0,59055	31	1,22047	47	1,85039	63	2,48031	79	3,11024	95	3,74016	117	4,60630
16	0,62992	32	1,25984	48	1,88976	64	2,51969	80	3,14961	96	3,77953	118	4,64567

How it works?

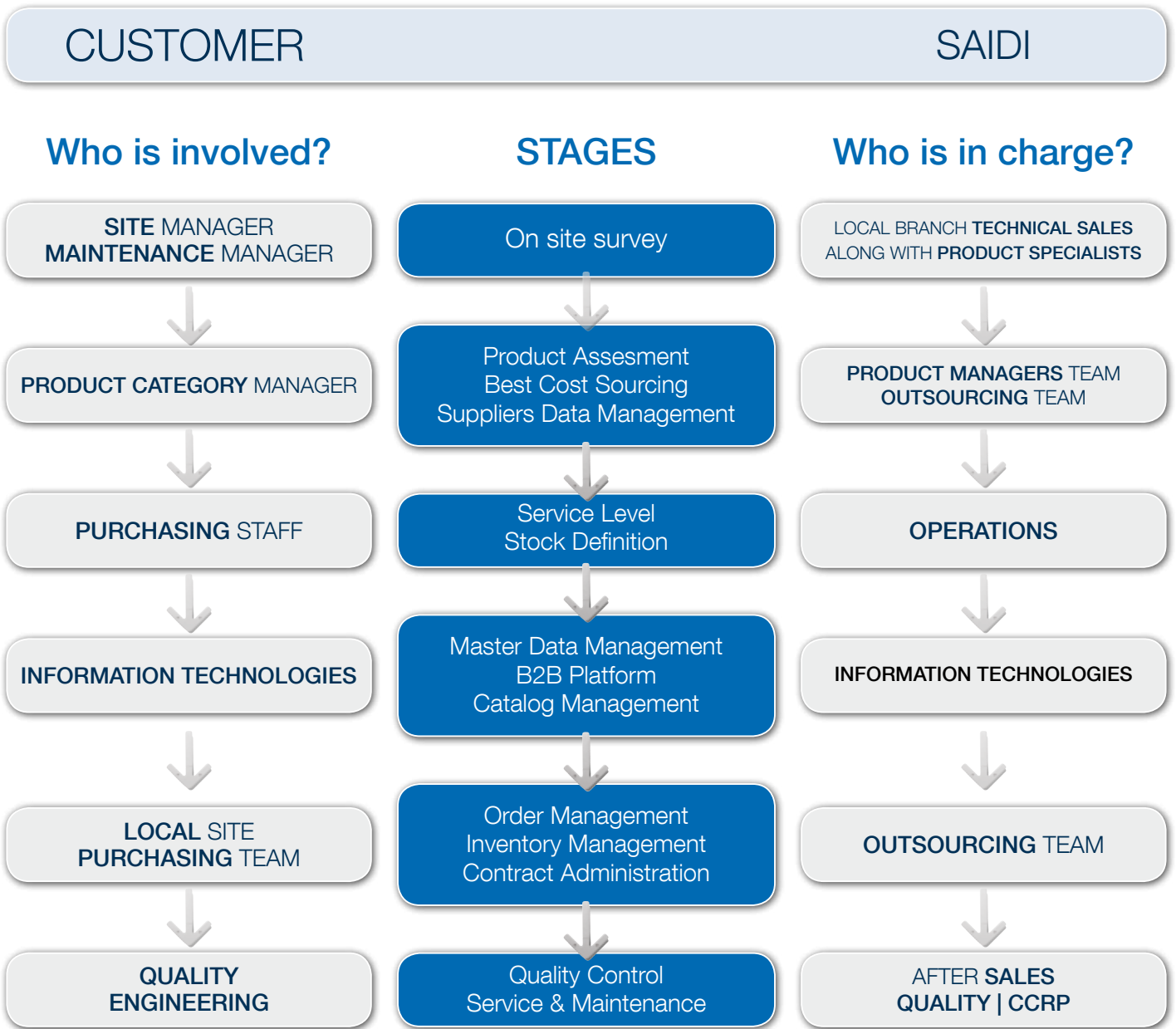

Escanea este código QR y descárgate la presentación de SAIDI OUTSOURCING

Scan this QR code and download the presentation of SAIDI OUTSOURCING

outsourcing@saidi.es



REPSOL



ABENGOA SOLAR



DIRECCIONES



OFICINAS CENTRALES

Av. del Llano Castellano, 15
28034 Madrid (Spain)
T +34 913 581 212
F +34 913 580 488
gral@saidi.es



CENTRO DE OPERACIONES

C/. Mas del Conde, s/nº
Pol. Masía de Baló
46394 Ribarroja del Turia (Valencia)
Apdo. Correos 288
Logistics Centre T +34 961 640 339
Service Centre T +34 961 640 303
clv@saidi.es | ssc@saidi.es



KLINGER SAIDI MÉXICO

C/. Alfredo Nobel No. 3, Bodega 2
Colonia Fracc. Ind. Los Reyes,
Municipio de Tlalnepantla
CP 54073 Estado de México
(México)
T +52 (55) 5565 1026
mexico@klingersaidi.mx

DELEGACIONES

ANDALUCÍA

C/ Astronomía, 1
Parque Empresarial Nuevo Torneo
Torre 3, 2ª Pl., Ofic. 7 y 8 - 41015 Sevilla
Tel. 954 437 500 | Fax 954 434 278
andalucia@saidi.es

CATALUÑA y BALEARES

C/ de la Telemática, 11- Pol. Ind. "La Ferrería"
08110 Montcada i Reixach (Barcelona)
Tel. 935 751 970 | Fax 935 750 910
barcelona@saidi.es

LEVANTE

C/. Mas del Conde, s/nº
Pol. Masía de Baló
46394 Ribarroja del Turia (Valencia)
Apdo. Correos 288
Tel. 961 640 330 | Fax 961 640 337
levante@saidi.es

ASTURIAS

C/. Corín Tellado, 22 Bajo
33204 Gijón
Tel. 985 337 093 | Fax 985 337 145
asturias@saidi.es

CENTRO

Avda. Castilla, 53 - Nave nº 3
28830 San Fernando de Henares (Madrid)
Tel. 916 088 165 | Fax 916 767 012
castilla@saidi.es

NORTE

Av. Ibaibe, 31 - Edif. GARVE I Planta 1ª Dpto. 5
48901 Baracaldo (Vizcaya)
Tel. 944 380 012 | Fax 944 780 559
norte@saidi.es

CANARIAS

C/ Cíncel Nº71
Pol.Ind. Arinaga P3 Norte
35118 Agüimes (Gran Canaria)
Tel. 928 184 658 | Fax 928 122 444
canarias@saidi.es

GALICIA

Pol. Ind. "Pocomaco", Parcela D - 4
Portal Nº 5 - 1ª Planta
15190 Mesoiro (A Coruña)
Tel. 981 294 166 | Fax 981 290 367
galicia@saidi.es

OFICINAS COMERCIALES

MURCIA

Tel. 961 640 330 | Fax 961 640 337
murcia@saidi.es

TARRAGONA

Tel. 961 640 330 | Fax 961 640 337
tarragona@saidi.es

VIGO

Tel. 981 29 41 66 | M 626 31 06 98
asturias@saidi.es

PUERTOLLANO

Tel. 961 640 330 | Fax 961 640 337
puertollano@saidi.es

VALLADOLID

Tel. 985 33 70 93 | M 648 75 46 10
asturias@saidi.es

ZARAGOZA

Tel. 961 640 330 | Fax 961 640 337
aragon@saidi.es



BRANCH NETWORK

Close to the customer



Key Leyenda

-  Sales Branch Office
Delegación
-  Headquarters
Oficinas Centrales
-  Distribution Centre
Centro de Distribución
-  Logistics & Service Centre
Centro Logístico y de Servicio

KLINGER SAIDI SPAIN
Av. del Llano Castellano, 15
28034 Madrid
T +34 91 358 12 12
F +34 91 358 04 88
gral@saidi.es